



## Notice: Upcoming Improvements

### OVERNIGHT SEWER SYSTEM INSPECTIONS: INFLOW & INFILTRATION REDUCTION PROGRAM

Crews will be in neighborhoods accessing sewer lines through manholes as part of an analysis of wastewater flow. The goal is to identify portions of the sewer system where stormwater and groundwater are possibly entering the system.

Leaks could lead to problems such as increased treatment cost and reduced system capacity. The results of this analysis will be used to plan future sewer system improvement projects.

The City of Fort Lauderdale is working with Ardurra Group Inc. to study the flow of wastewater throughout the City's sewer system over the next three years. Crews began analyzing overnight wastewater flows in July 2024 and expect to complete this work in November 2025.

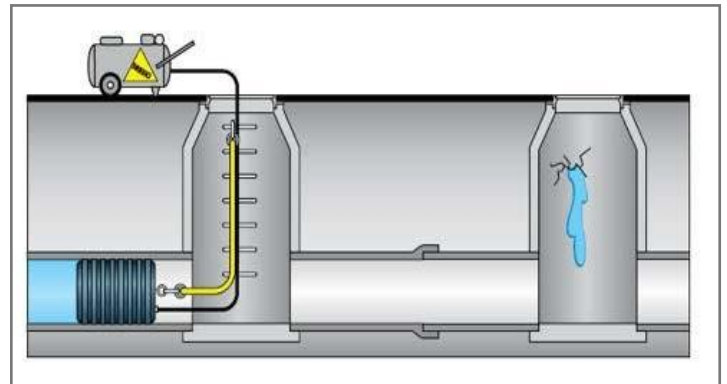

#### What to Expect

Inspections will take place Sunday through Thursday evenings between 11 p.m. and 7 a.m. Crews will be accessing sewer lines through sewer manholes. Therefore, no heavy machinery will be on site and minimal noise and lighting impacts are expected.

#### Traffic Impacts

- One lane in each direction of neighborhood streets may be closed temporarily during work hours.
- Traffic control personnel will direct traffic as needed.
- Access to driveways will be maintained.
- Please follow posted signs and drive with caution in the area.

#### Approximate Schedule

##### Sun., July 6 - Fri., July 11

Navarro Isle, Las Olas Isles, Hendricks and Venice Isles, Seven Isles, Idlewyld, Riviera Isles, Central Beach, Harbor Beach, Harbor Drive, Harbour Inlet, Breakwater Surf and Harbour Isles

##### Sun., July 13 - Tues., July 15

Harbordale and Rio Vista

##### Tues., July 15 - Wed., July 23

Croissant Park, River Oaks and Tarpon River

##### Wed., July 23 - Mon., July 28

Central Beach

##### Mon., July 28 - Mon., Aug. 4

Poinsettia Heights

This schedule is subject to change based on inclement weather or other unforeseen circumstances. We apologize in advance for any inconvenience and thank you for your patience while we complete this important analysis. To see a map of the areas where night flow isolation is scheduled and learn more about the City's efforts to reduce inflow and infiltration, visit [ftlcity.info/iandi](http://ftlcity.info/iandi).

#### For more information or questions, contact:

##### Inflow and Infiltration Program Hotline

877-332-4037 or [ftlii@ardurra.com](mailto:ftlii@ardurra.com)

If you would like this publication in an alternate format, please call 954-828-4755 or email [strategiccommunications@fortlauderdale.gov](mailto:strategiccommunications@fortlauderdale.gov).

