

NOTES:

1. METALLIC WARNING TAPES SHALL BE INSTALLED 24" BELOW FINISH GRADE ABOVE MAIN. (SEE SPECIFICATION 2320 SECTION 3.6 FOR MARKING TYPE)
2. UNLESS OTHERWISE SPECIFIED SELECTED MATERIAL SHALL BE FREE OF STONES LARGER THAN 3/8" DIA.
3. REPLACE ALL LANE MARKINGS AND REFLECTIVE MARKERS.

T=6" PARKING
 T=8" RESIDENTIAL STREETS
 T=10" MAJOR STREETS (4 LANE)
 T=12" MAJOR STREETS (6 LANE)

2T=18" MAX. 12" MIN.



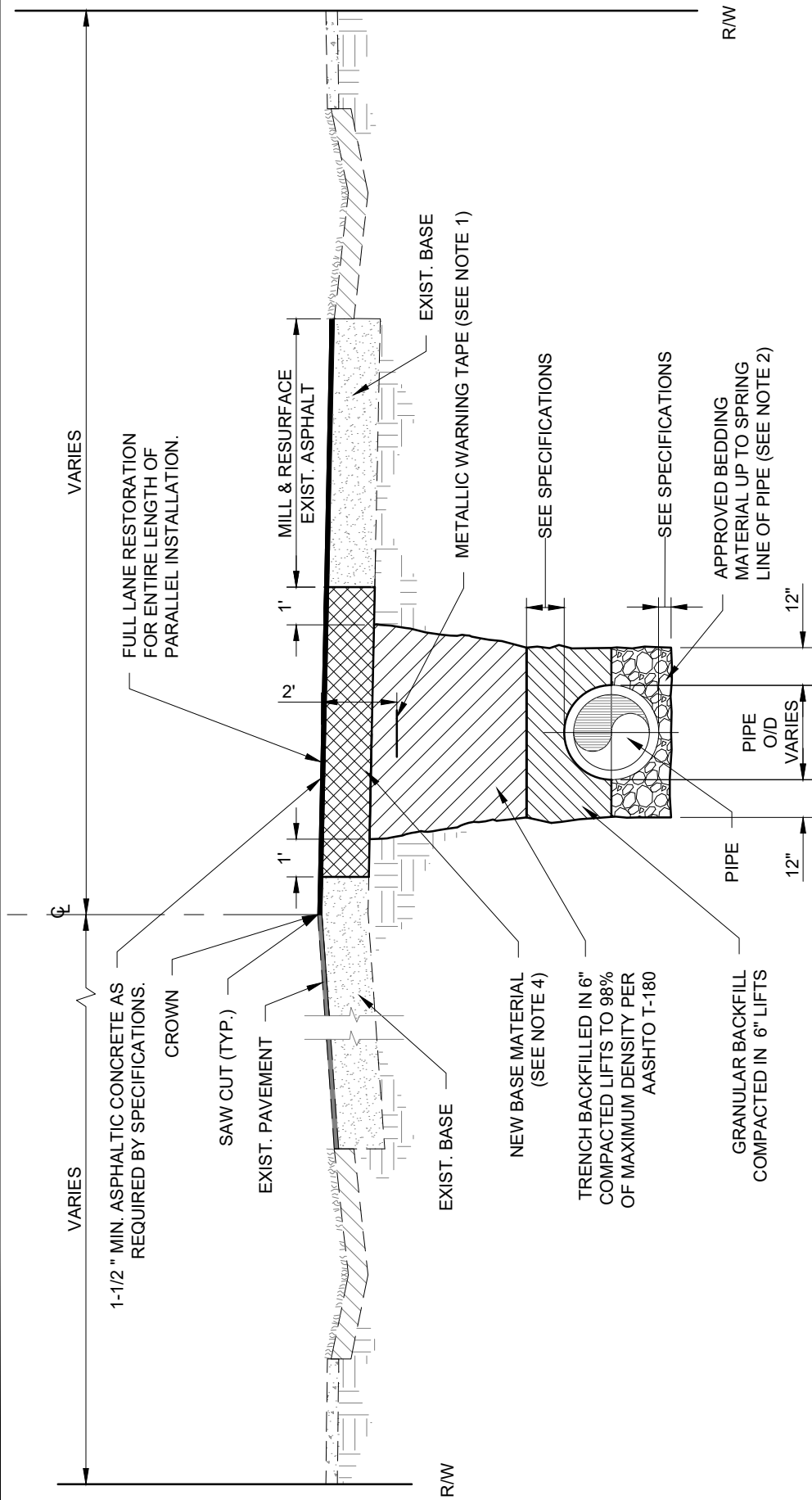

NOTES:

1. 2" WIDE METALLIC WARNING TAPES SHALL BE INSTALLED 24" BELOW FINISH GRADE.
2. UNLESS OTHERWISE SPECIFIED SELECTED MATERIAL SHALL BE FREE OF STONES LARGER THAN 3/8" DIA.
3. REPLACE ALL LANE MARKINGS AND REFLECTIVE MARKERS.
4. 12" MIN. LIMEROCK BASE PLACED IN 6" LAYERS AND COMPACTED TO 98% OF MAXIMUM DENSITY PER AASHTO T-180.

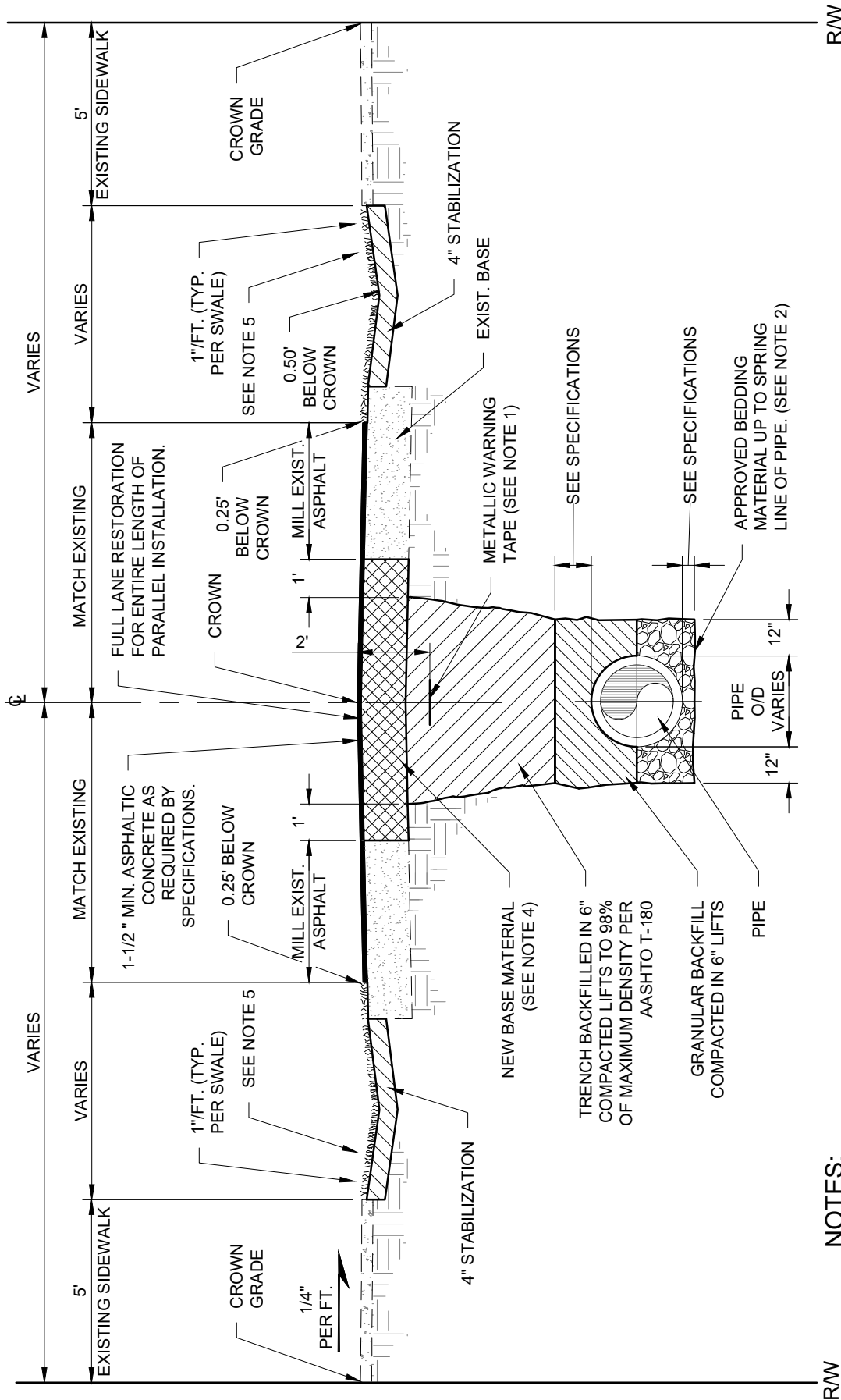

NOTES:

1. 2" WIDE METALLIC WARNING TAPES SHALL BE INSTALLED 24" BELOW FINISH GRADE. DOES NOT APPLY TO STORM DRAINAGE PIPE INSTALLATION.
2. UNLESS OTHERWISE SPECIFIED SELECTED MATERIAL SHALL BE FREE OF STONES LARGER THAN 3/8" DIA.
3. REPLACE ALL LANE MARKINGS AND REFLECTIVE MARKERS.
4. 12" MIN. LIMEROCK BASE PLACED IN 6" LAYERS AND COMPACTED TO 98% OF MAXIMUM DENSITY PER AASHTO T-180
5. BAHIA SOD -OR- ST. AUGUSTINE "FLORITAM" SOD IN PREVIOUSLY SODDED AREAS -OR- REPLACE EXISTING IMPROVED SURFACE (e.g., ROCK OR ASPHALT PAVING TO MATCH EXISTING -IF ASPHALT, MINIMUM 1" ASPHALT OVER MINIMUM 6" COMPACTED LIMEROCK)



CITY OF FORT LAUDERDALE
PUBLIC WORKS DEPARTMENT
ENGINEERING DETAILS

100 North Andrews Avenue, Fort Lauderdale, Florida 33301

TYPICAL ROAD SECTION, TYPICAL TRENCH, PAVEMENT AND SWALE RESTORATION FOR PARALLEL PIPE TRENCH

SHEET 3

DETAIL NO.
**ROAD
003**

REVISED:
2017/08/07

RAILROAD COMPANY	CLEARANCE BELOW BOTTOM OF RAIL (FEET)*	STRENGTH
		ASTM (C76) CLASS
CSX TRANSPORTATION	5.5	V
FLORIDA EAST COAST (FEC) RAILROAD COMPANY	5.5	VI
SOUTH FLORIDA REGIONAL TRANSPORTATION AUTHORITY (TRI-COUNTY COMMUTER RAIL)	5.5	V

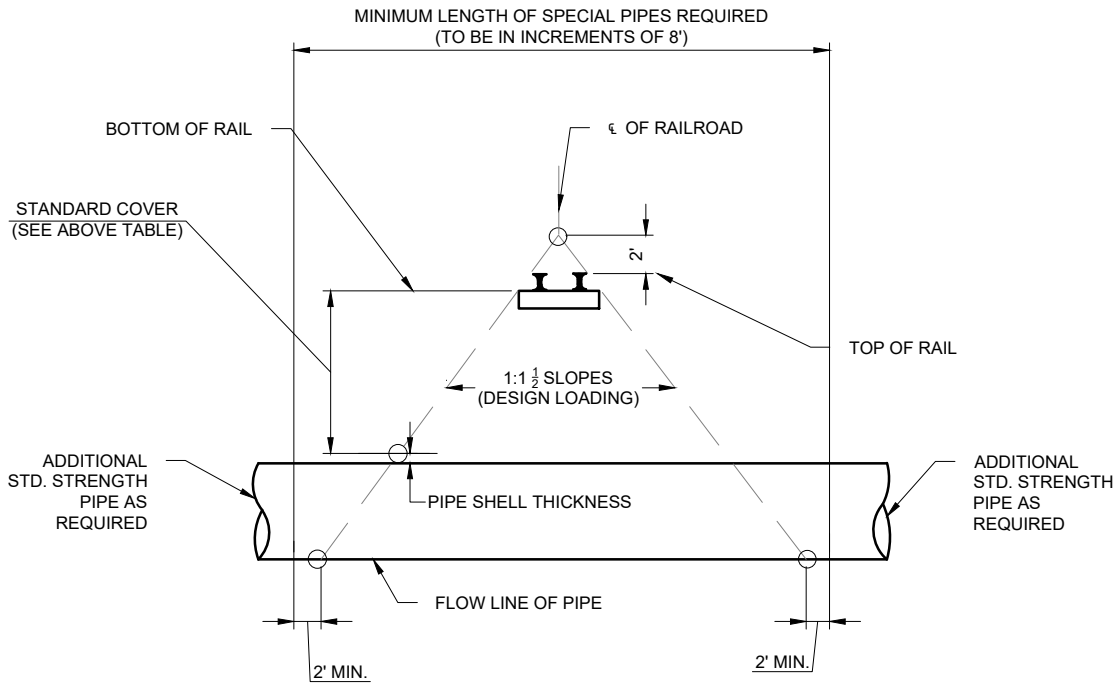

METHOD FOR DETERMINING THE LENGTH OF SPECIAL PIPE REQUIRED UNDER RAILROADS



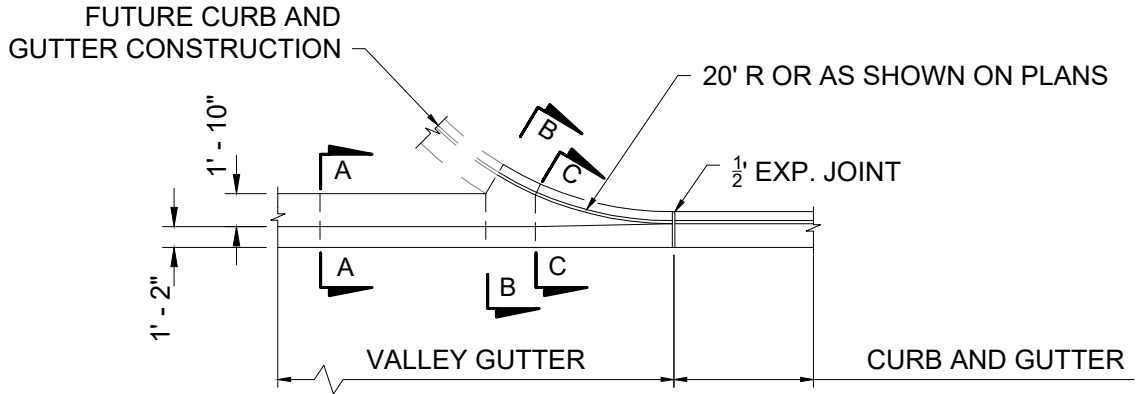

PLAN

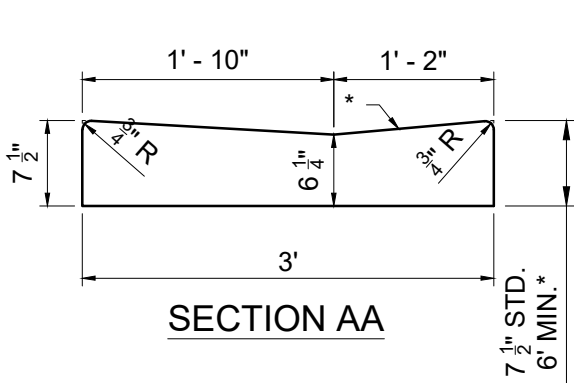

SECTION AA

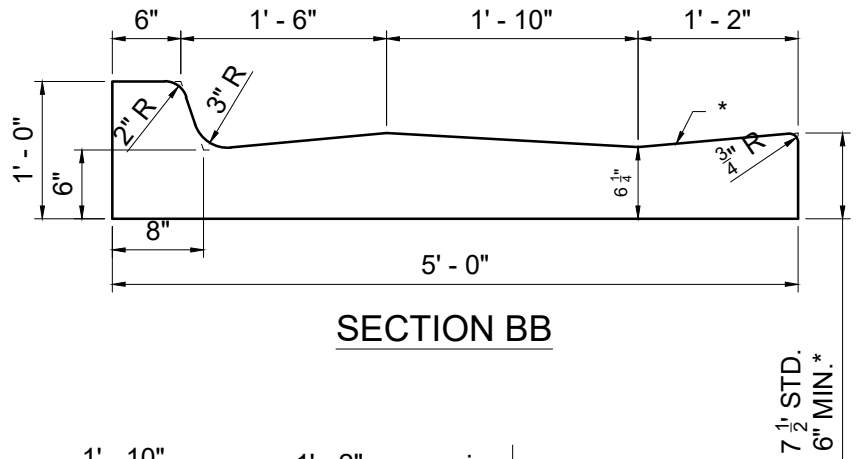

SECTION BB

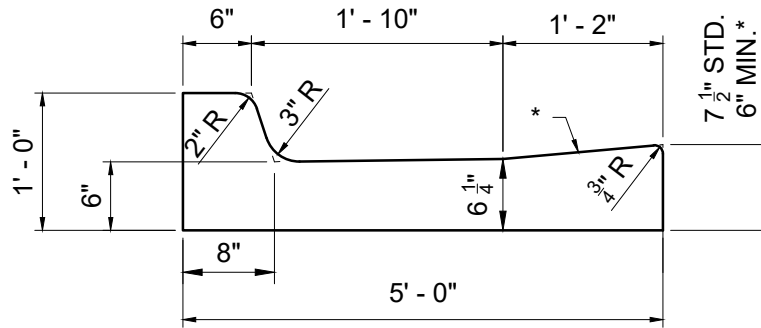

SECTION CC

NOTES:

1. WHEN USED ON HIGH SIDE OF ROADWAYS, THE CROSS SLOPE OF THE GUTTER SHALL MATCH THE CROSS SLOPE OF THE ADJACENT PAVEMENT. THE THICKNESS OF THE LIP SHALL BE 6", UNLESS OTHERWISE SHOWN ON PLANS.
2. ROTATE ENTIRE SECTION SO THAT GUTTER CROSS SLOPE MATCHES SLOPE OF ADJACENT CIRCULATING ROADWAY PAVEMENT.
3. FOR USE ADJACENT TO CONCRETE OR FLEXIBLE PAVEMENT. FOR DETAILS DEPICTING USAGE ADJACENT TO FLEXIBLE PAVEMENT, SEE SHEET 2. EXPANSION JOINT, PREFORMED JOINT FILLER AND JOINT SEAL ARE REQUIRED BETWEEN CURB & GUTTER AND CONCRETE PAVEMENT ONLY, SEE SHEET 2.
4. 4" CURB PAD (LBR 100, 98% COMPACTION T-180) TO BE PLACED UNDER CURB AND GUTTER, AND EXTEND 6" BEYOND OUTSIDE EDGE OF CURB. SEE SPECIFICATIONS FOR MATERIAL



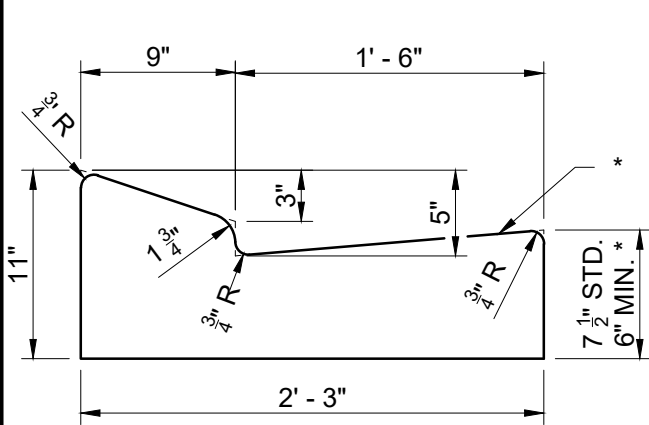

TYPE E

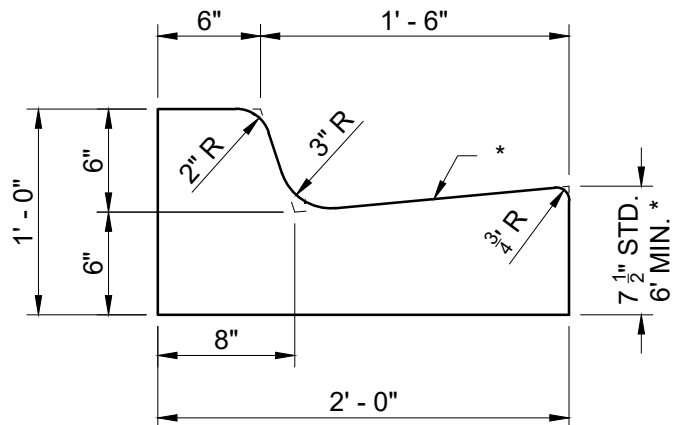

TYPE F

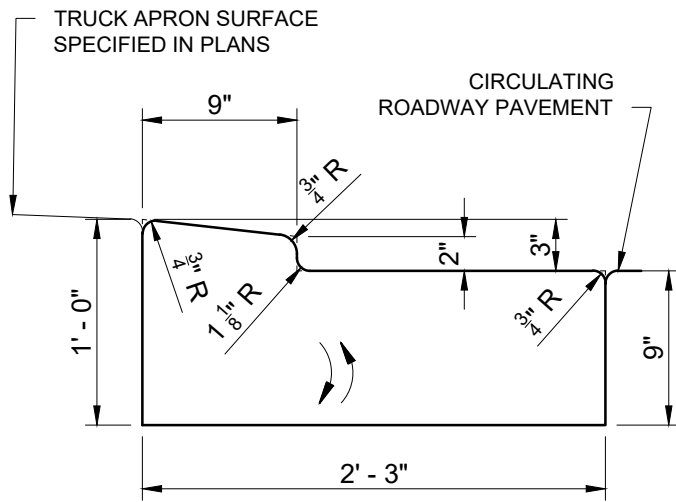

TRAFFIC BEARING SECTION FOR USE IN
ROUNDBOUT CENTRAL ISLAND CONSTRUCTION

TYPE RA

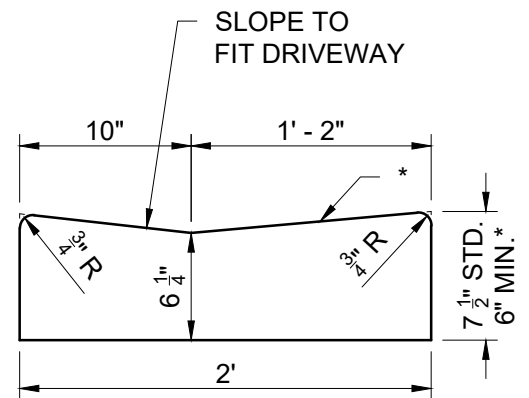

DROP CURB

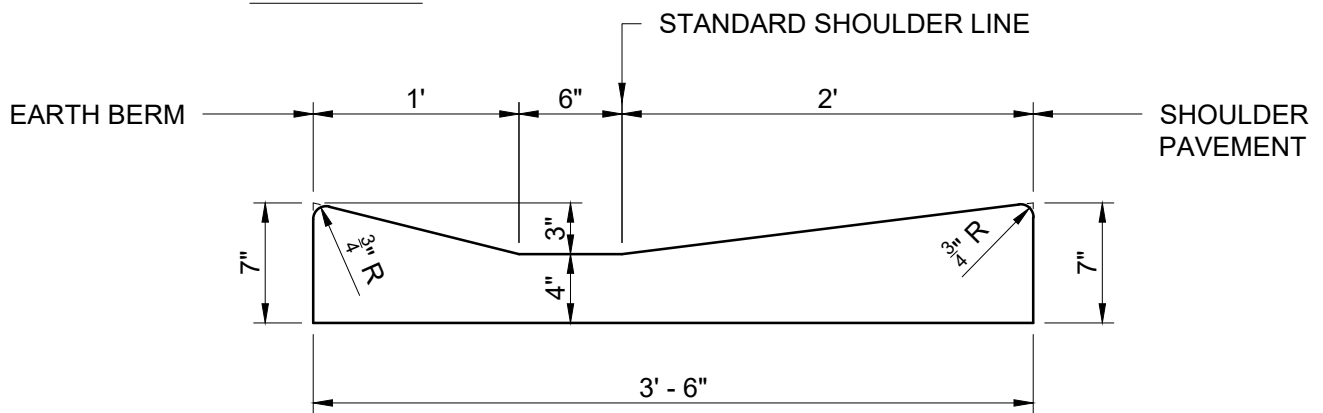

SHOULDER GUTTER

NOTE:

4" CURB PAD (LBR 100, 98% COMPACTION T-180) TO BE PLACED UNDER CURB AND GUTTER, AND EXTEND 6" BEYOND OUTSIDE EDGE OF CURB. SEE SPECIFICATIONS FOR MATERIAL



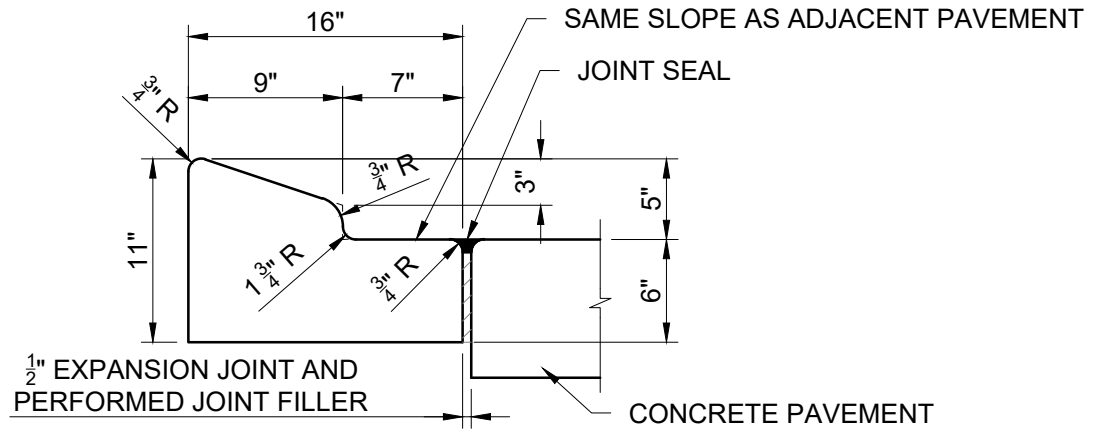

TYPE A

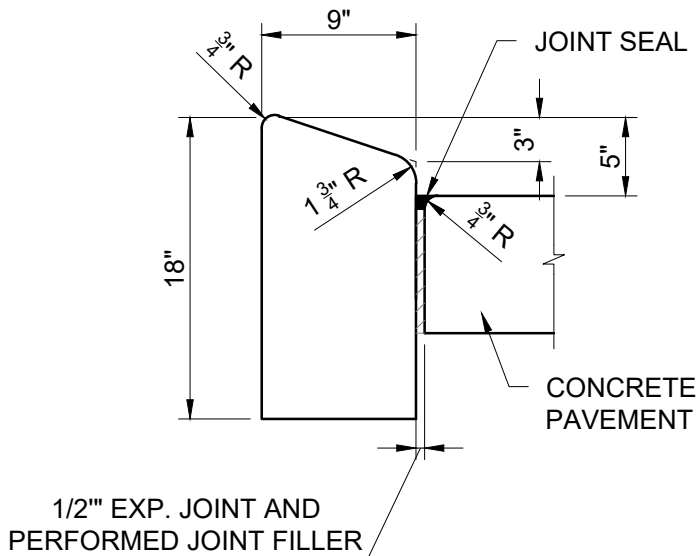

TYPE B

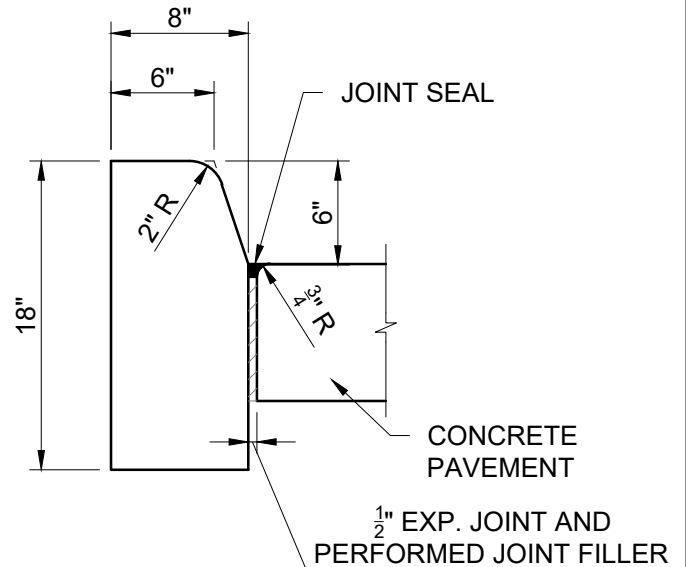

TYPE D

NOTES:

1. FOR USE ADJACENT TO CONCRETE OR FLEXIBLE PAVEMENT, CONCRETE SHOWN. EXPANSION JOINT, PREFORMED JOINT FILLER AND JOINT SEAL ARE REQUIRED BETWEEN CURBS AND CONCRETE PAVEMENT ONLY.
2. 4" CURB PAD (LBR 100, 98% COMPACTION T-180) TO BE PLACED UNDER CURB AND GUTTER, AND EXTEND 6" BEYOND OUTSIDE EDGE OF CURB. SEE SPECIFICATIONS FOR MATERIAL



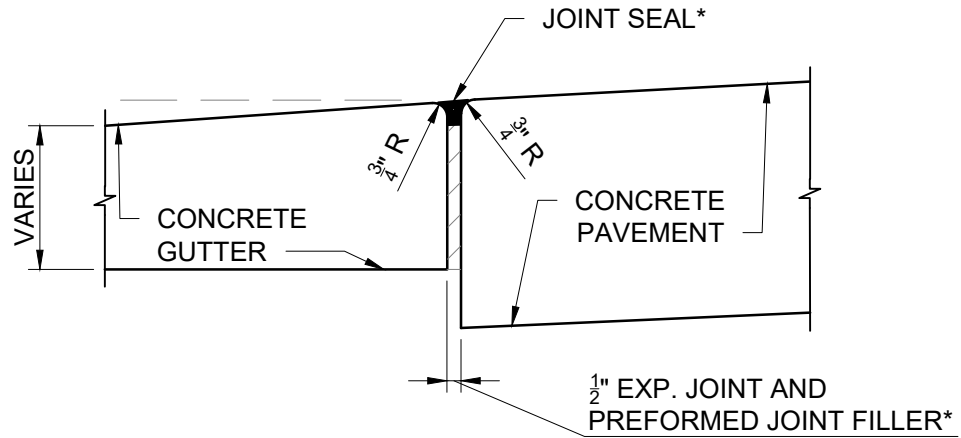

* APPLIES TO BOTH HIGH AND LOW SIDES OF PAVEMENT, LOW SIDE SHOWN.



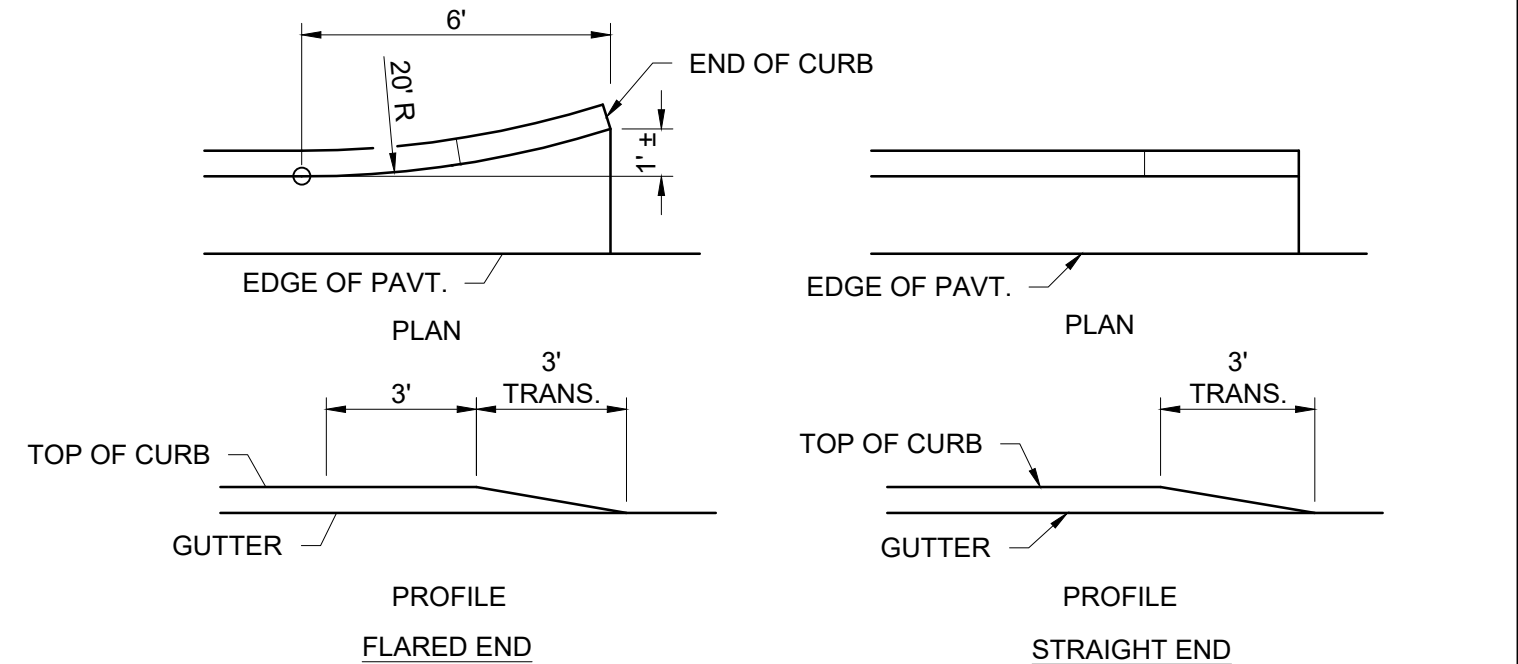
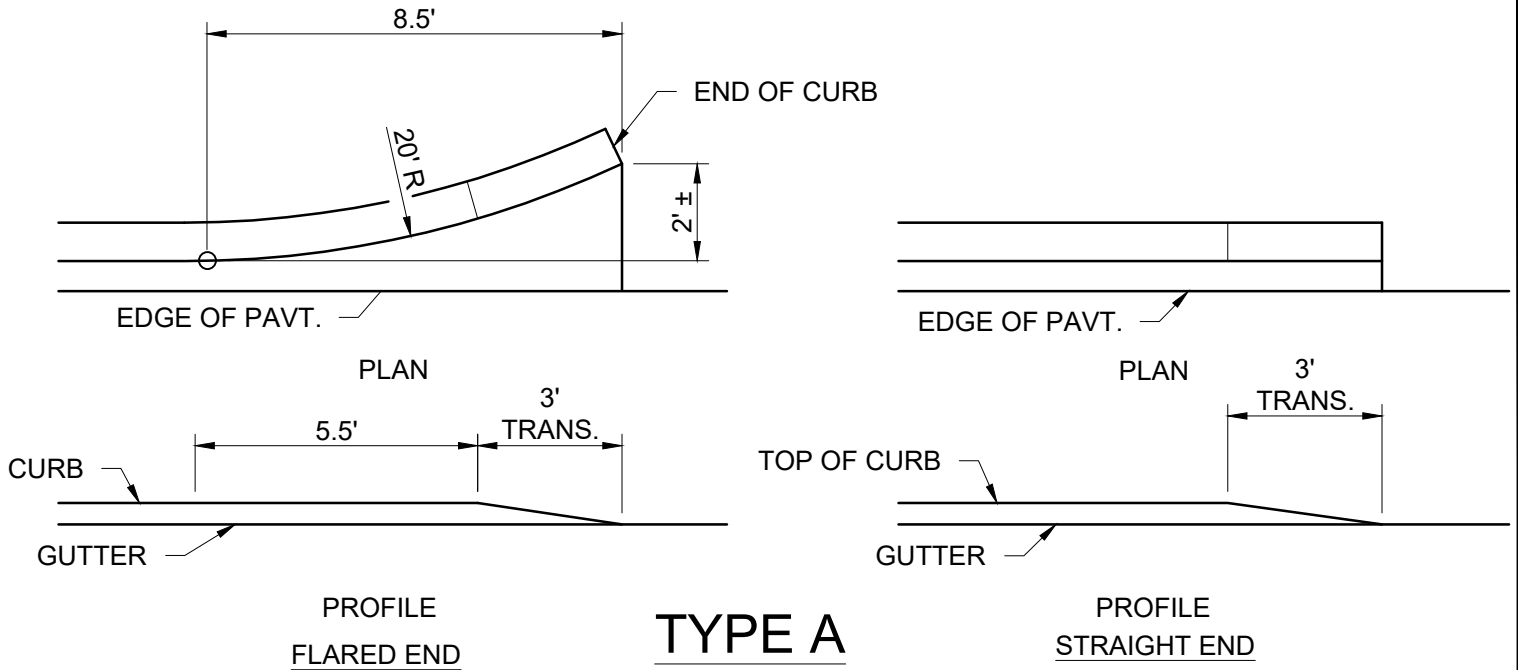

NOTES:

1. FOR CURB, GUTTER AND CURB & GUTTER PROVIDE $\frac{1}{8}$ " - $\frac{1}{4}$ " CONTRACTION JOINTS AT 10' CENTERS (MAX.). CONTRACTION JOINTS ADJACENT TO CONCRETE PAVEMENT ON TANGENTS AND FLAT CURVES ARE TO MATCH THE PAVEMENT JOINTS, WITH INTERMEDIATE JOINTS NOT TO EXCEED 10' CENTERS. CURB, GUTTER AND CURB & GUTTER EXPANSION JOINTS SHALL BE LOCATED IN ACCORDANCE WITH SECTION 520 OF THE STANDARD SPECIFICATIONS.
2. ENDS OF CURBS TYPES B AND D SHALL TRANSITION FROM FULL TO ZERO HEIGHTS IN 3'.



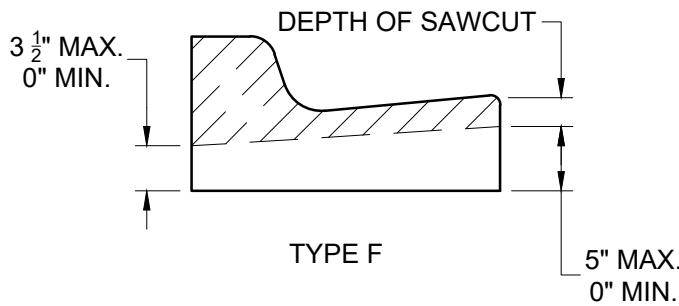
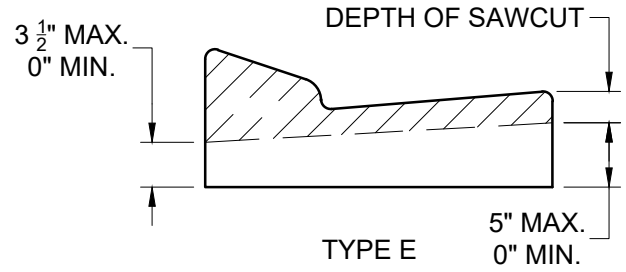
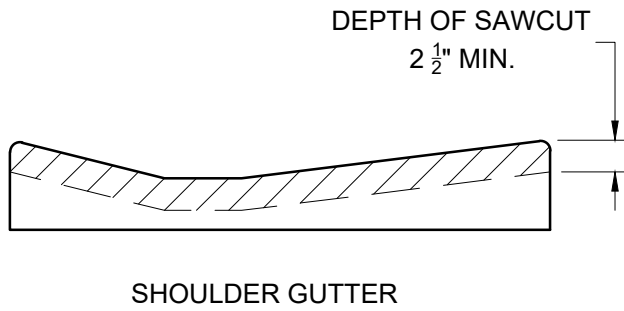

SAWCUTS SHOULD BE AVOIDED WITHIN VALLEY GUTTER AND WITHIN CURB AND GUTTER ENDINGS.

NOTES:

1. FOR CURB, GUTTER AND CURB & GUTTER PROVIDE 1/8" - 1/4" CONTRACTION JOINTS AT 10' CENTERS (MAX.). CONTRACTION JOINTS ADJACENT TO CONCRETE PAVEMENT ON TANGENTS AND FLAT CURVES ARE TO MATCH THE PAVEMENT JOINTS, WITH INTERMEDIATE JOINTS NOT TO EXCEED 10' CENTERS. CURB, GUTTER AND CURB & GUTTER EXPANSION JOINTS SHALL BE LOCATED IN ACCORDANCE WITH SECTION 520 OF THE STANDARD SPECIFICATIONS.
2. ENDS OF CURBS TYPES B AND D SHALL TRANSITION FROM FULL TO ZERO HEIGHTS IN 3'.



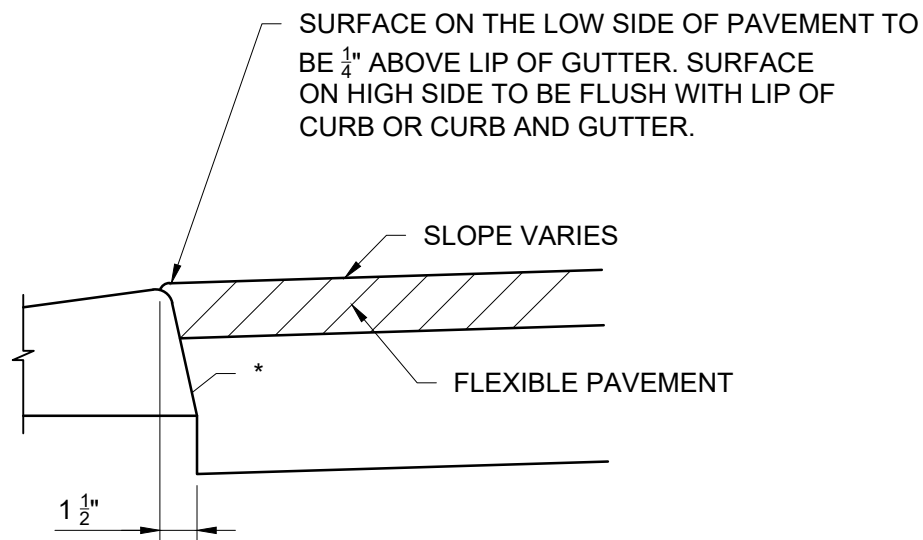
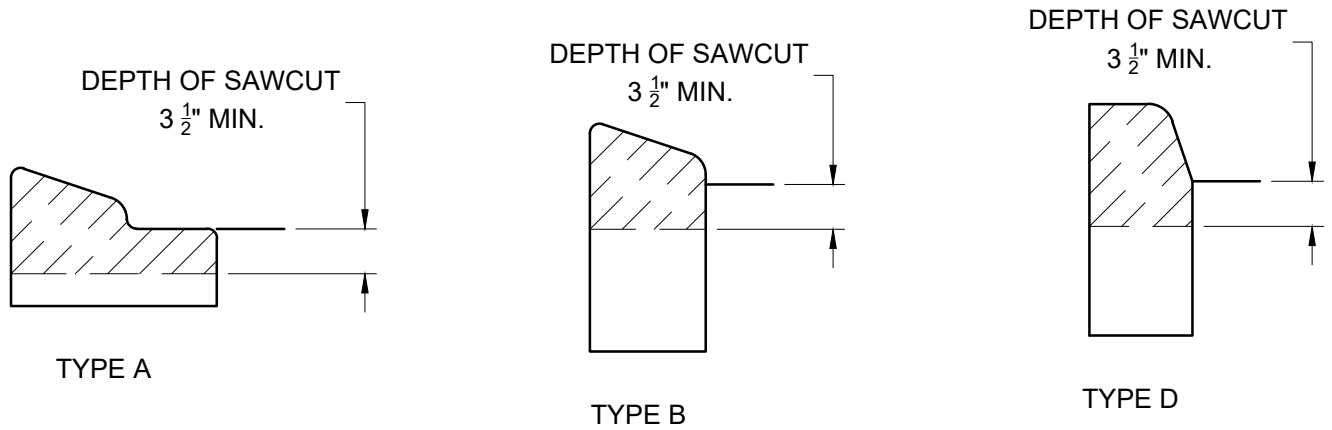

* APPLIES TO BOTH HIGH AND LOW SIDES OF PAVEMENT, LOW SIDE SHOWN. APPLIES TO SHOULDER GUTTER ONLY WHERE ADJOINING TRAFFIC LANES.

NOTES:

1. FOR CURB, GUTTER AND CURB & GUTTER PROVIDE 1/8" - 1/4" CONTRACTION JOINTS AT 10' CENTERS (MAX.). CONTRACTION JOINTS ADJACENT TO CONCRETE PAVEMENT ON TANGENTS AND FLAT CURVES ARE TO MATCH THE PAVEMENT JOINTS, WITH INTERMEDIATE JOINTS NOT TO EXCEED 10' CENTERS. CURB, GUTTER AND CURB & GUTTER EXPANSION JOINTS SHALL BE LOCATED IN ACCORDANCE WITH SECTION 520 OF THE STANDARD SPECIFICATIONS.
2. ENDS OF CURBS TYPES B AND D SHALL TRANSITION FROM FULL TO ZERO HEIGHTS IN 3'.



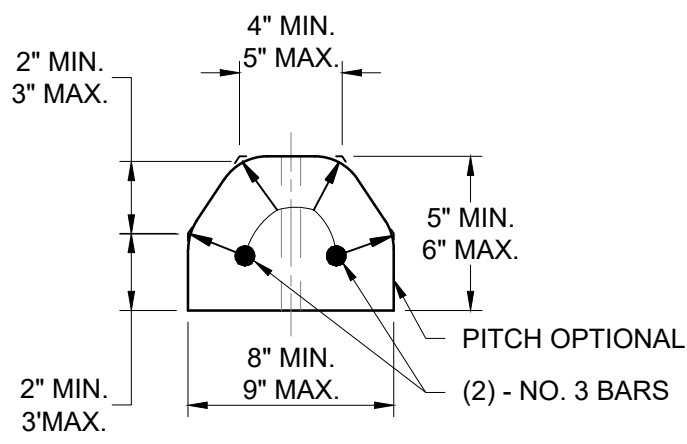
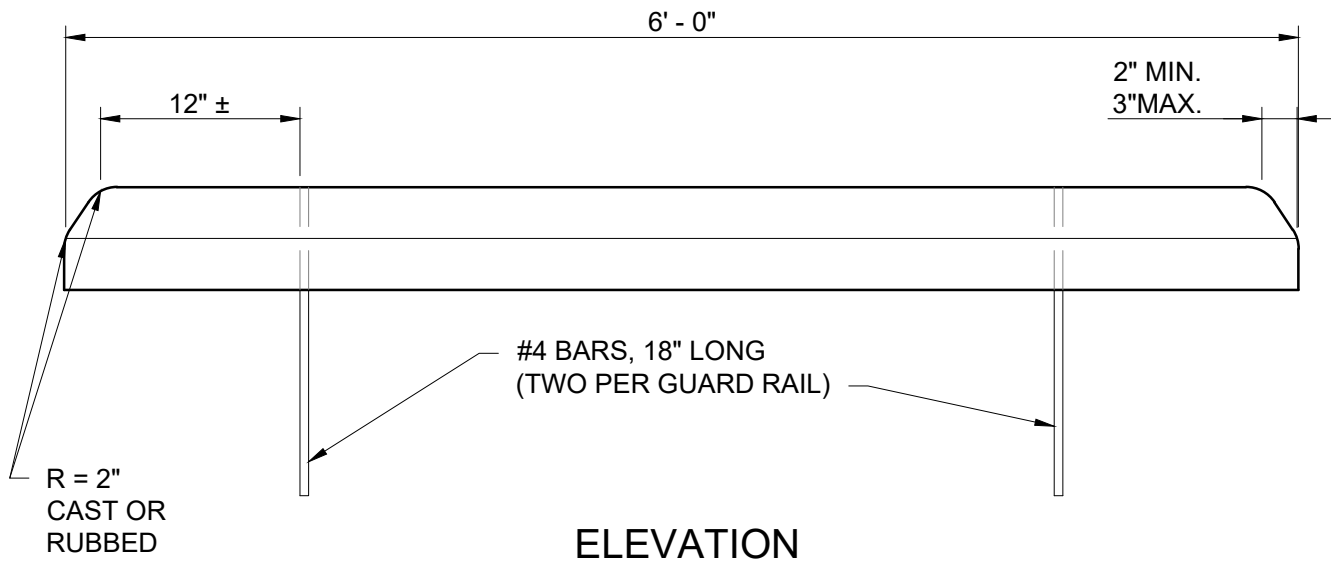

GENERAL NOTES

1. SIDEWALK CURB RAMPS SHALL BE CONSTRUCTED AT LOCATIONS THAT WILL PROVIDE CONTINUOUS UNOBSTRUCTED PEDESTRIAN CIRCULATION PATH TO PEDESTRIAN AREAS, ELEMENTS AND FACILITIES WITHIN THE RIGHT OF WAY AND TO ACCESSIBLE PEDESTRIAN ROUTES ON ADJACENT SITES. CURBED FACILITIES WITH SIDEWALKS AND THOSE WITHOUT SIDEWALKS ARE TO HAVE CURB RAMPS CONSTRUCTED FOR ALL INTERSECTIONS AND TURNOUTS WITH CURBED RETURNS. TO ACCOMMODATE CURB RAMPS, PARTIAL CURB RETURNS ARE TO EXTEND TO THE LIMITS PRESCRIBED IN INDEX NO. 515. RAMPS CONSTRUCTED AT LOCATIONS WITHOUT SIDEWALKS ARE TO HAVE A LANDING CONSTRUCTED AT THE TOP OF EACH RAMP, SEE LANDINGS FOR CURB RAMPS WITHOUT SIDEWALKS.
2. WHEN ALTERING EXISTING PEDESTRIAN FACILITIES, WHERE EXISTING RESTRICTED CONDITIONS PRECLUDE THE ACCOMMODATION OF A RAMP SLOPE OF 1:12, A RAMP SLOPE BETWEEN 1:12 AND 1:10 IS PERMITTED FOR A RISE OF 6" MAXIMUM. WHERE COMPLIANCE WITH THE REQUIREMENTS FOR CROSS SLOPE CANNOT BE FULLY MET, THE MINIMUM FEASIBLE CROSS SLOPE SHALL BE PROVIDED. RAMP SLOPES ARE NOT REQUIRED TO EXCEED 15' IN LENGTH.
3. IF SIDEWALK CURB RAMPS ARE LOCATED WHERE PEDESTRIANS MUST WALK ACROSS THE RAMP, THEN PROVIDE TRANSITION SLOPES TO THE RAMP; OTHERWISE A SIDEWALK CURB MAY BE REQUIRED.
4. ALL SIDEWALKS, RAMPS, AND LANDINGS WITH A CROSS SLOPE OF 0.02 SHOWN IN THIS INDEX ARE 0.02 MAXIMUM. ALL RAMP SLOPES SHOWN IN THIS INDEX AS 1:12 ARE 1:12 MAXIMUM. LANDINGS SHALL HAVE SLOPES LESS THAN OR EQUAL TO 0.02 IN ANY DIRECTION.
5. GRADE BREAKS AT THE TOP AND BOTTOM OF RAMPS SHALL BE PARALLEL TO EACH OTHER AND PERPENDICULAR TO THE DIRECTION OF THE RAMP SLOPE.
6. WHERE A SIDEWALK CURB RAMP IS CONSTRUCTED WITHIN EXISTING CURB, CURB AND GUTTER AND/OR SIDEWALK, THE EXISTING CURB OR CURB AND GUTTER SHALL BE REMOVED TO THE NEAREST JOINT BEYOND THE CURB TRANSITION OR TO THE EXTENT THAT NO REMAINING SECTION OF CURB OR CURB AND GUTTER IS LESS THAN 5' LONG. EXISTING SIDEWALKS SHALL BE REMOVED TO THE NEAREST JOINT BEYOND THE TRANSITION SLOPE OR TO THE EXTENT THAT NO REMAINING SECTION OF SIDEWALK IS LESS THAN 5' LONG. FOR CONCRETE SIDEWALK DETAILS REFER TO INDEX 310.
7. SIDEWALK CURB RAMP ALPHA-IDENTIFICATIONS ARE FOR REFERENCE PURPOSES (PLANS, PERMITS, ETC.). ALPHA-IDENTIFICATIONS CR-I AND CR-J WERE INTENTIONALLY OMITTED.
8. DETECTABLE WARNINGS SHALL EXTEND THE FULL WIDTH OF THE RAMP AND TO A DEPTH OF 2'. DETECTABLE WARNINGS SHALL BE CONSTRUCTED IN ACCORDANCE WITH SPECIFICATION SECTION 527. FOR THE LAYOUT OF DETECTABLE WARNINGS, REFER TO THE TYPICAL PLACEMENT OF DETECTABLE WARNINGS DETAILS. DETECTABLE WARNINGS SHALL NOT BE PROVIDED ON TRANSITION SLOPES.
9. WHEN DETECTABLE WARNINGS ARE PLACED ON A SLOPE GREATER THAN 5%, DOMES SHALL BE ALIGNED WITH THE CENTERLINE OF THE RAMP; OTHERWISE DOMES ARE NOT REQUIRED TO BE ALIGNED.
10. DETECTABLE WARNINGS SHALL BE REQUIRED ON SIDEWALKS AND SHARED USE PATHS AT:
 - A. INTERSECTING ROADS
 - B. MEDIAN CROSSINGS GREATER THAN OR EQUAL TO 6' IN WIDTH
 - C. RAILROAD CROSSINGS
 - D. SIGNALIZED DRIVEWAYS
11. DETECTABLE WARNINGS - ACCEPTANCE CRITERIA:
 - A. COLOR AND TEXTURE SHALL BE COMPLETE AND UNIFORM
 - B. 90% OF INDIVIDUAL TRUNCATED DOMES SHALL BE IN
 - C. ACCORDANCE WITH THE AMERICANS WITH DISABILITIES ACT STANDARDS FOR TRANSPORTATION FACILITIES, SECTION 705
 - D. THERE SHALL BE NO MORE THAN 4 NON-COMPLIANT DOMES IN ANY ONE SQUARE FOOT
 - E. NON-COMPLIANT DOMES SHALL NOT BE ADJACENT TO OTHER NON-COMPLIANT DOMES
 - F. SURFACES SHALL NOT DEVIATE MORE THAN 0.10" FROM A TRUE PLANE
12. DETECTABLE WARNINGS SHALL BE INSTALLED NO GREATER THAN 5' FROM THE BACK OF CURB OR EDGE OF PAVEMENT.
13. DETECTABLE WARNINGS SHALL NOT BE INSTALLED OVER GRADE BREAKS.

LEGEND



DETECTABLE WARNINGS

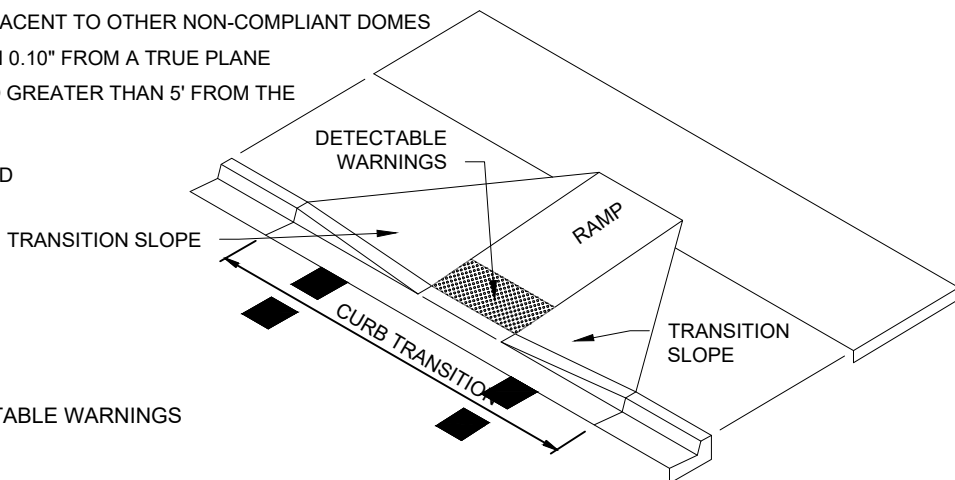

**CURB RAMP NOMENCLATURE
PICTORIAL VIEW**



CITY OF FORT LAUDERDALE
PUBLIC WORKS DEPARTMENT
ENGINEERING DETAILS

100 North Andrews Avenue, Fort Lauderdale, Florida 33301

DETECTABLE WARNINGS AND SIDEWALK CURB RAMPS

DETAIL NO.
ROAD
013

REVISED:
2017/03/11

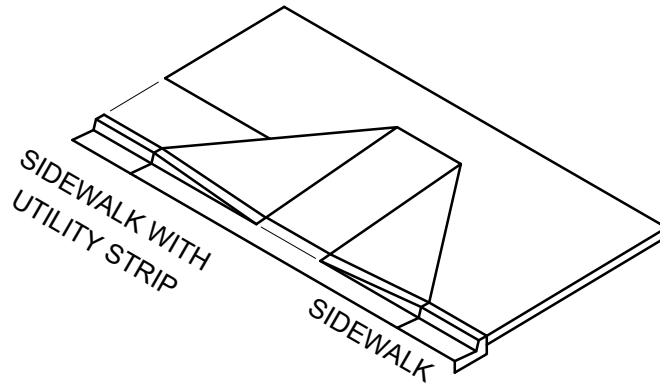

PICTORIAL VIEW

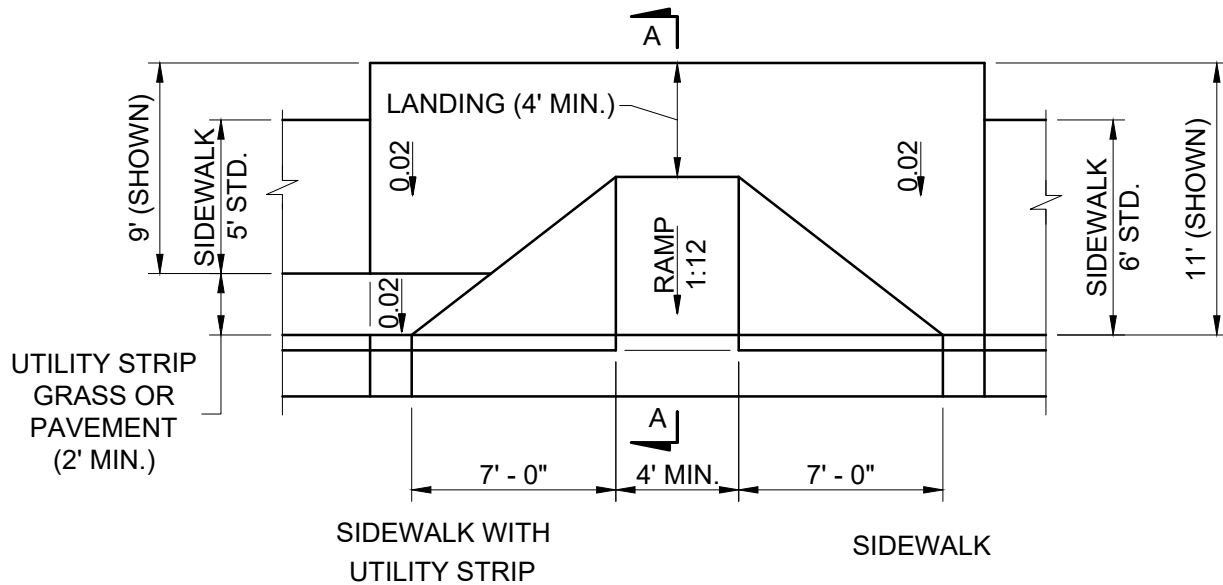

PLAN VIEW

CR-A

16" WHEN LOCATED ALONG TYPE 'F' CURB AND GUTTER

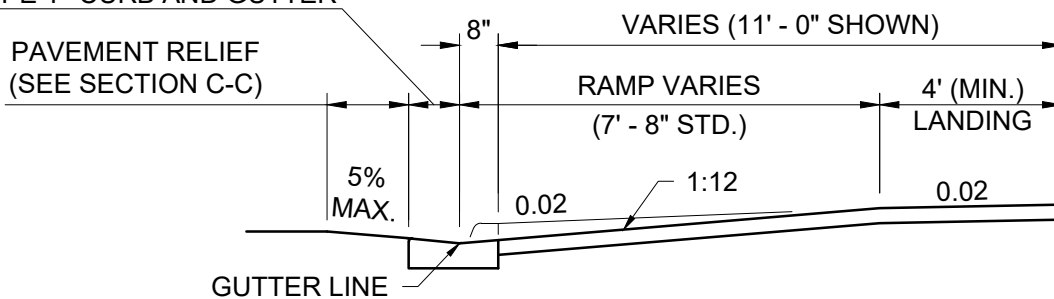

SECTION A-A

SECTION THROUGH RAMP AND LANDING
(UNRESTRICTED CONDITIONS)

RAMP AND LANDING DEPTHS NOT RESTRICTED



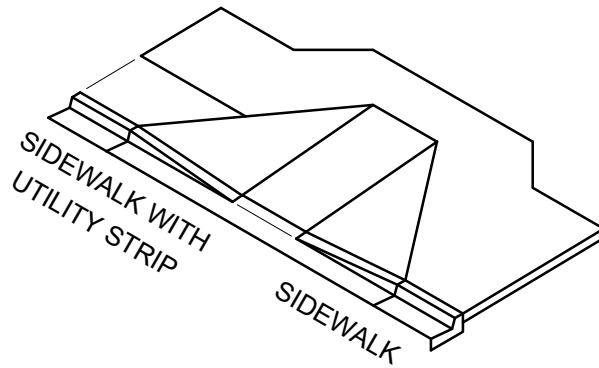

PICTORIAL VIEW

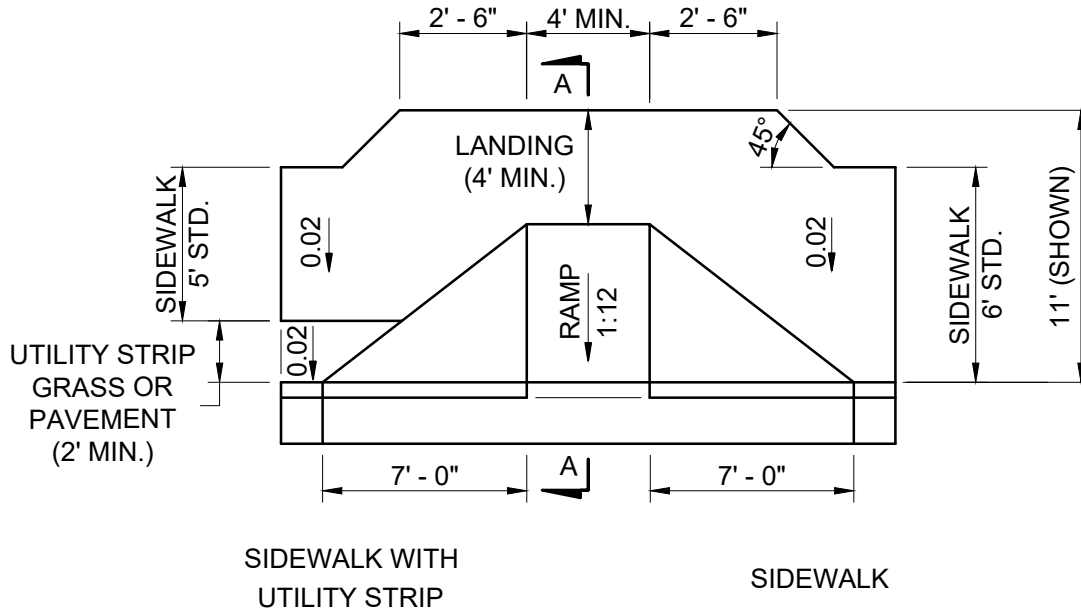

PLAN VIEW

CR-B

16" WHEN LOCATED ALONG TYPE 'F' CURB AND GUTTER

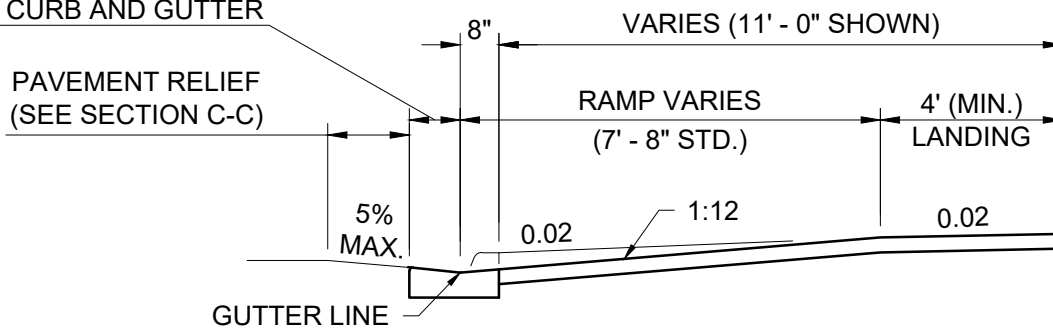

SECTION A-A

SECTION THROUGH RAMP AND LANDING
(UNRESTRICTED CONDITIONS)

RAMP AND LANDING DEPTHS ARE NOT RESTRICTED



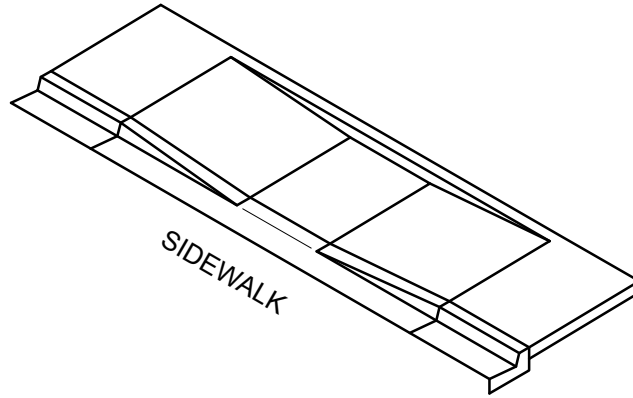

PICTORIAL VIEW

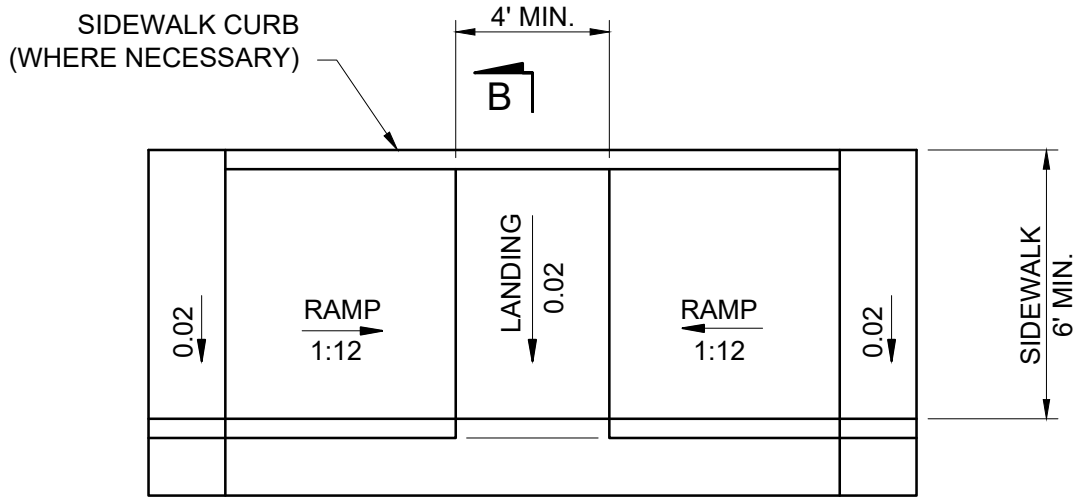

PLAN VIEW

CR-C

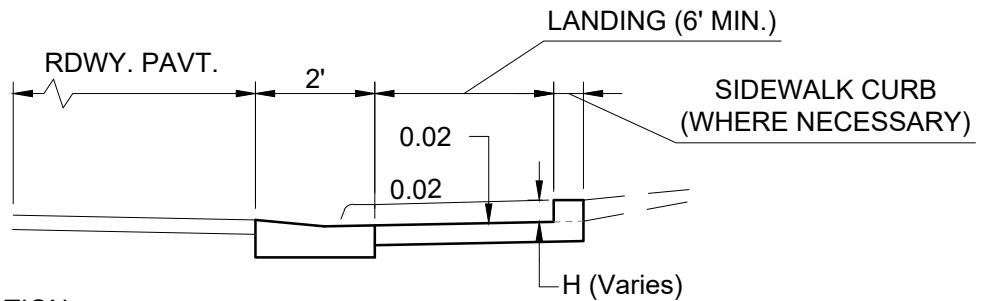

SECTION B-B

SECTION THROUGH LANDING
(UNRESTRICTED CONDITIONS)

NOTE:
FOR ADDITIONAL INFORMATION
ON SIDEWALK CURB
CONSTRUCTION, SEE SIDEWALK
CURB AND SIDEWALK CURB
OPTIONS DETAILS.

RAMP AND LANDING STRIPS NOT RESTRICTED



CITY OF FORT LAUDERDALE
PUBLIC WORKS DEPARTMENT
ENGINEERING DETAILS

100 North Andrews Avenue, Fort Lauderdale, Florida 33301

SIDEWALK CURB RAMPS
SHEET 3

DETAIL NO.
ROAD
016

REVISED:
2017/03/11

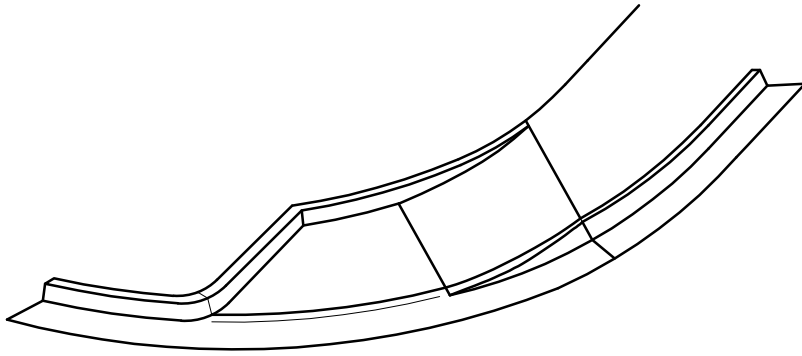

PICTORIAL VIEW

CR-D

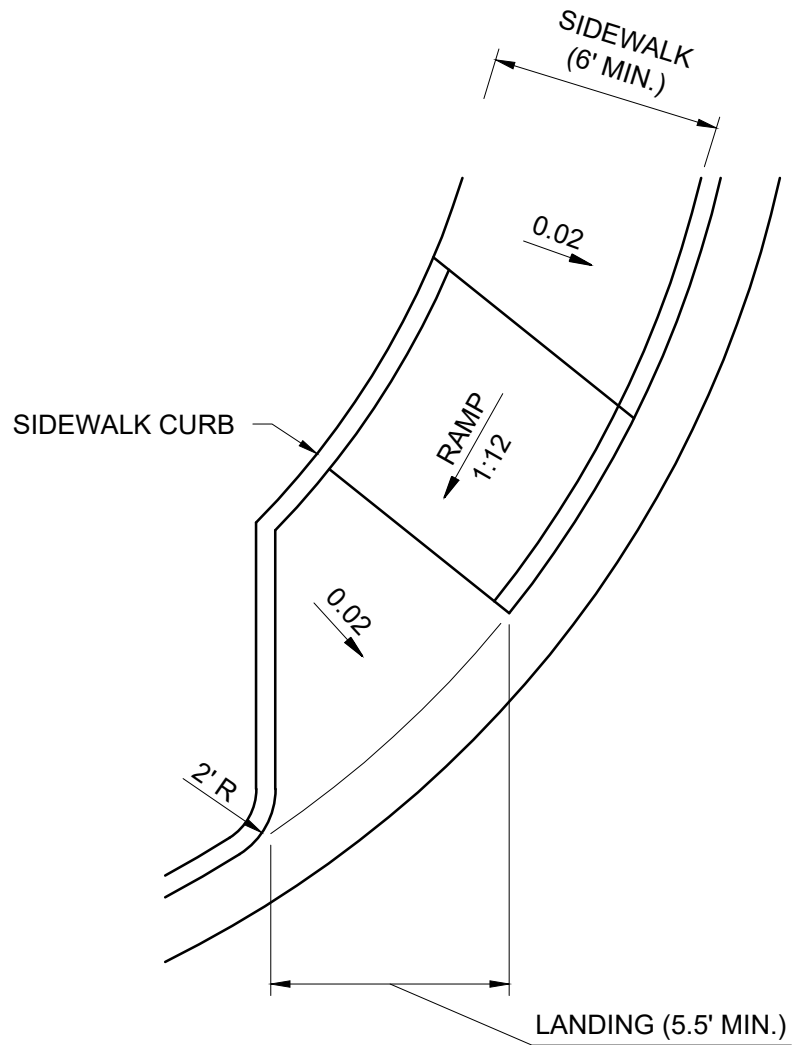

PLAN VIEW

CR-D

DIMENSIONAL FEATURES OF SIDEWALK CURB RAMPS FOR LINEAR PEDESTRIAN TRAFFIC



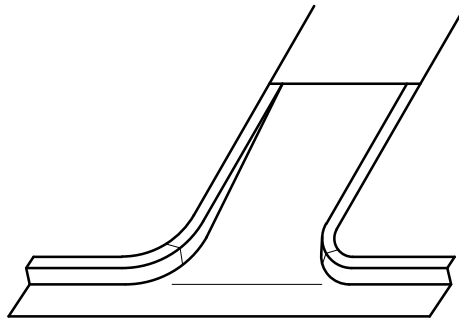

PICTORIAL VIEW

CR-E

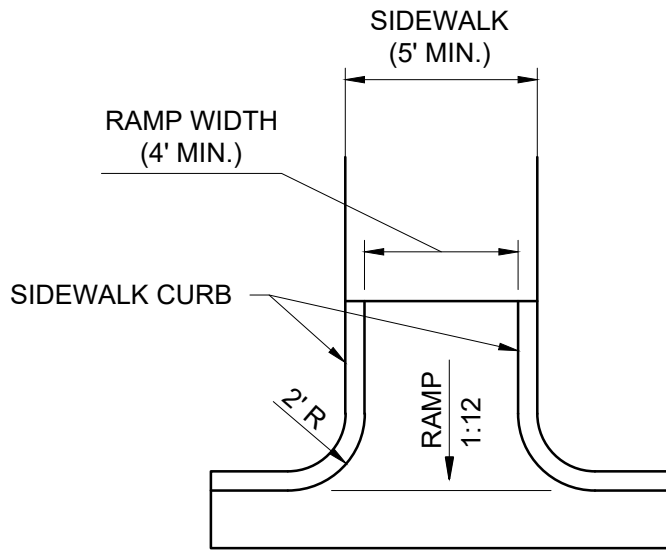

PLAN VIEW

CR-E

DIMENSIONAL FEATURES OF SIDEWALK CURB RAMPS FOR LINEAR PEDESTRIAN TRAFFIC



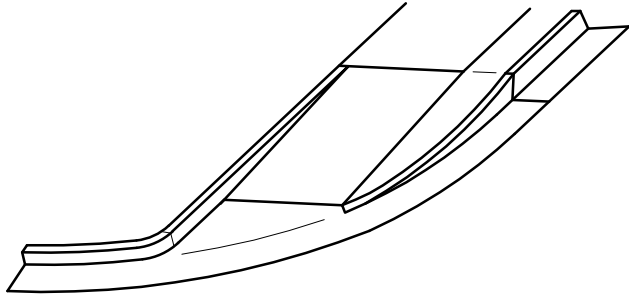

PICTORIAL VIEW

CR-F

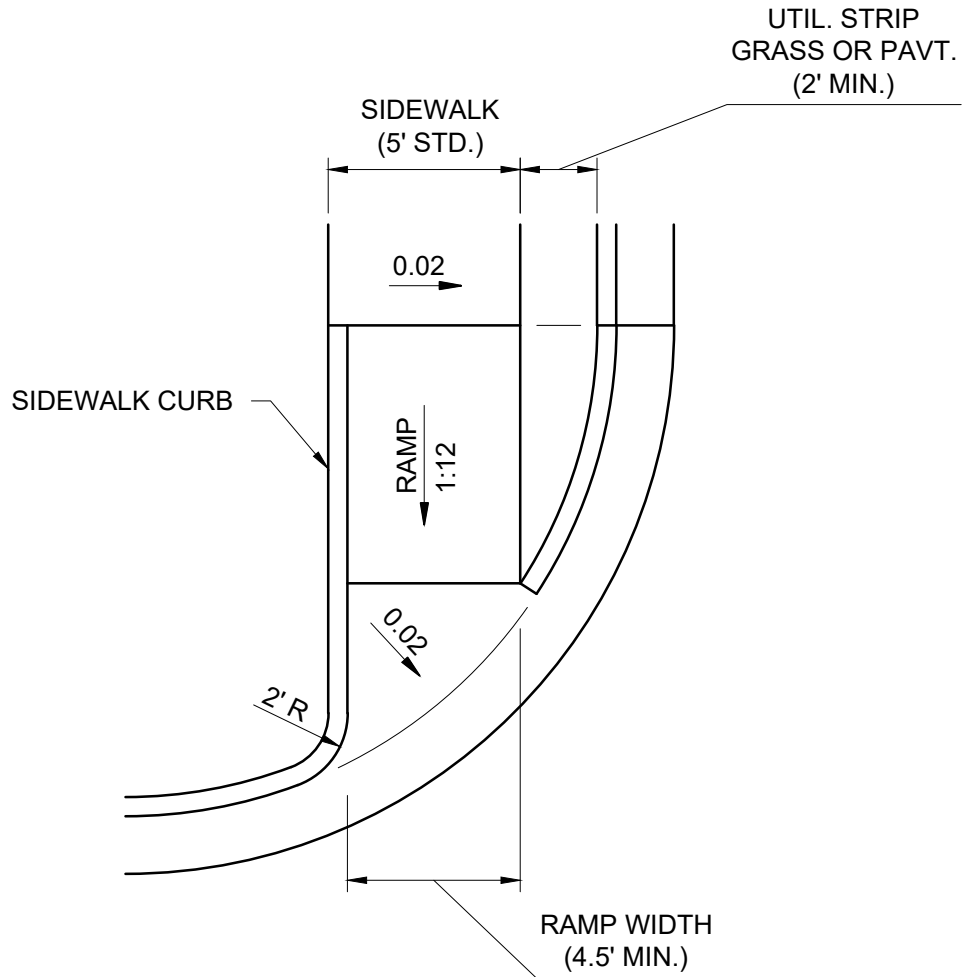

PLAN VIEW

CR-F

DIMENSIONAL FEATURES OF SIDEWALK CURB RAMPS FOR LINEAR PEDESTRIAN TRAFFIC



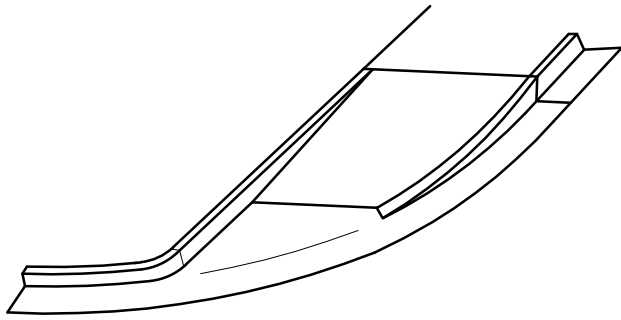

PICTORIAL VIEW

CR-G

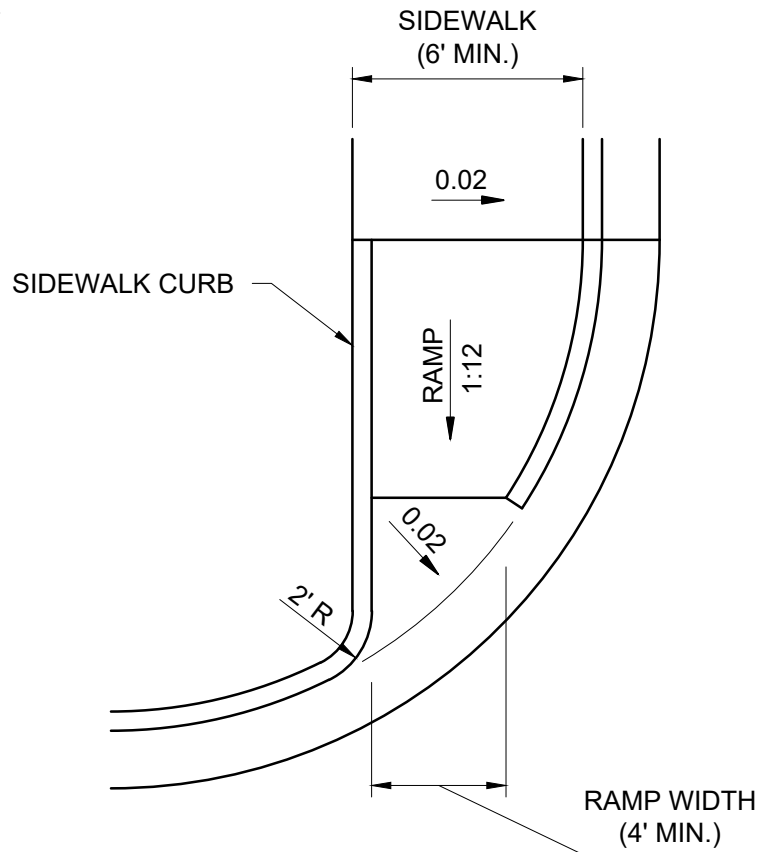

PLAN VIEW

CR-G

DIMENSIONAL FEATURES OF SIDEWALK CURB RAMPS FOR LINEAR PEDESTRIAN TRAFFIC



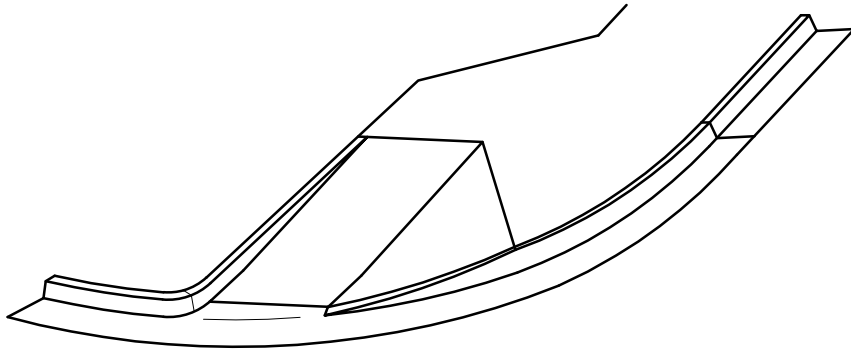

PICTORIAL VIEW

CR-H

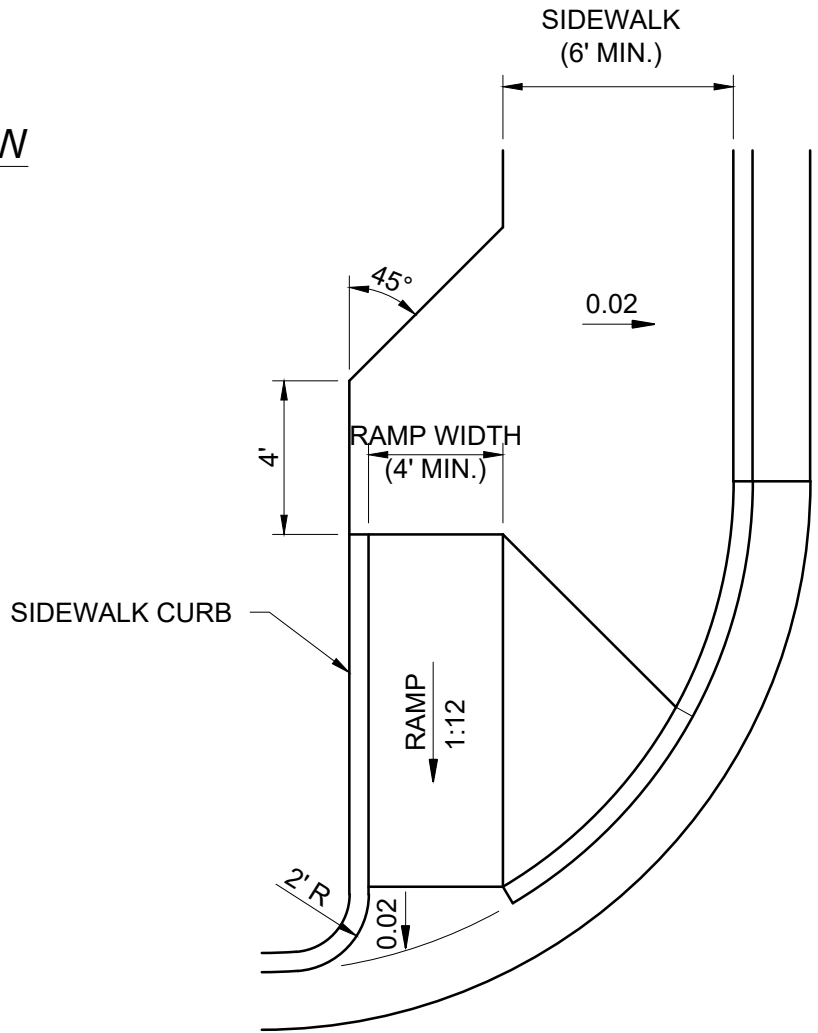

PLAN VIEW

CR-H

DIMENSIONAL FEATURES OF SIDEWALK CURB RAMPS FOR LINEAR PEDESTRIAN TRAFFIC



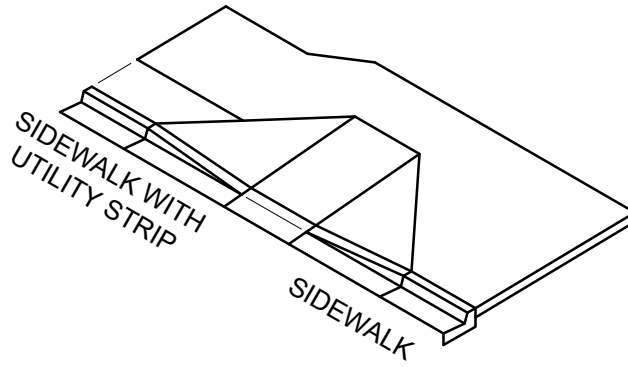

PICTORIAL VIEW

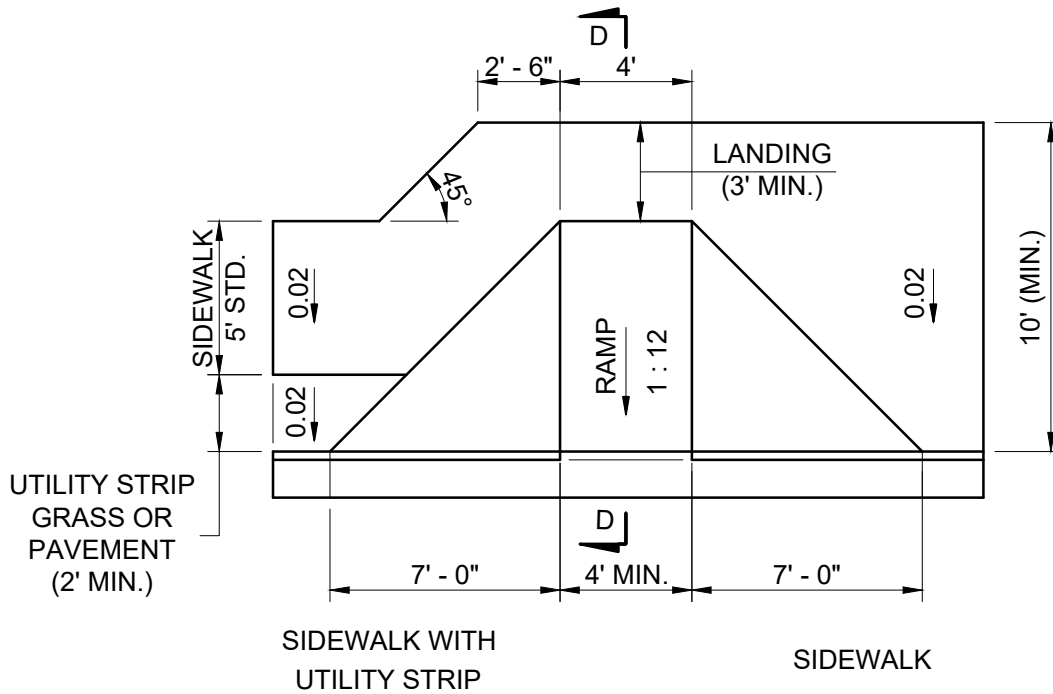

PLAN VIEW

CR-D

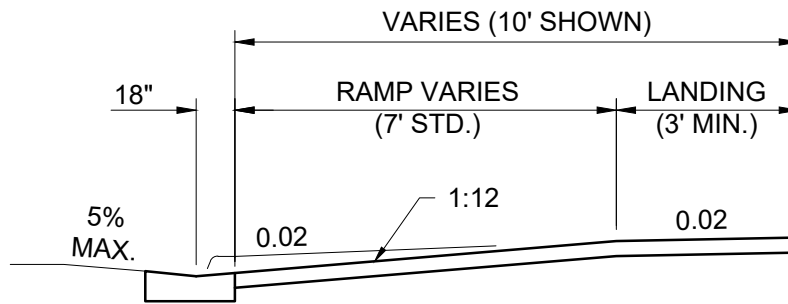

SECTION D-D

SECTION THROUGH RAMP AND LANDING
(RESTRICTED CONDITIONS)

SIDEWALK CURB RAMPS WHERE RAMP AND LANDING DEPTHS ARE RESTRICTED



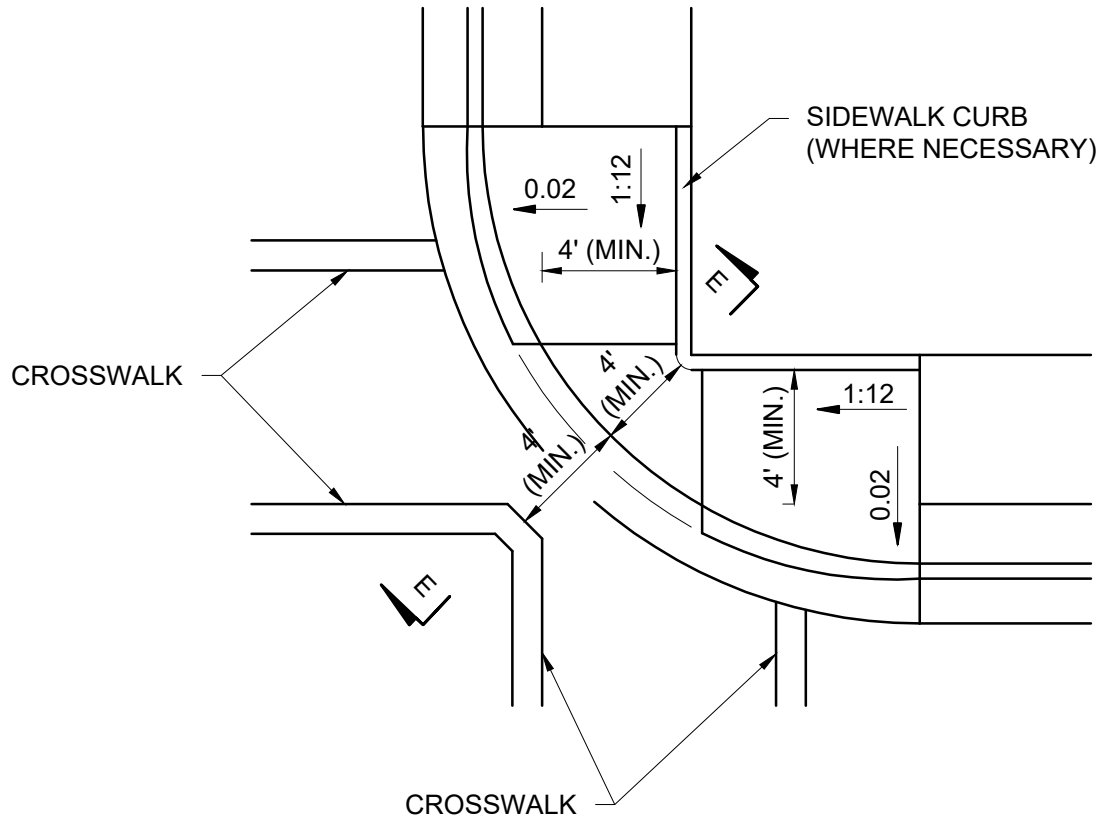

PLAN VIEW

CR-F

NOTE: CROSSWALK WIDTH AND CONFIGURATION VARY; MUST CONFORM TO INDEX NO. 17344 AND 17346. 15' RADIUS CURVE SHOWN FOR CR-L.

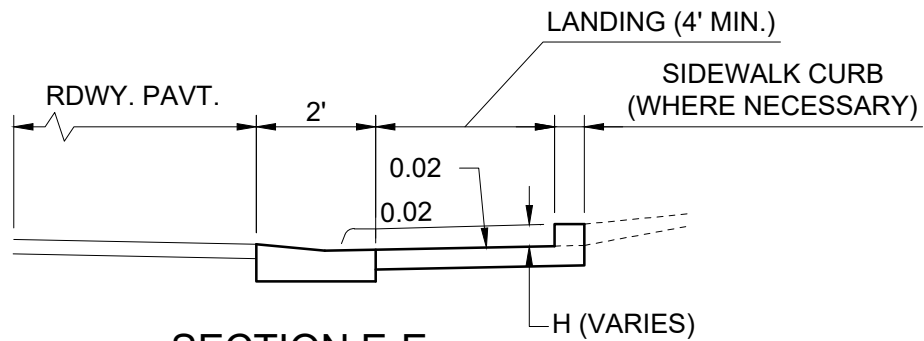

SECTION E-E

SECTION THROUGH LANDING
(RESTRICTED CONDITIONS)

SIDEWALK CURB RAMPS WHERE RAMP AND LANDING DEPTHS ARE RESTRICTED



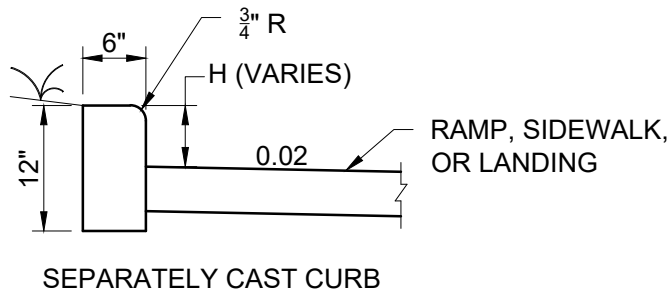
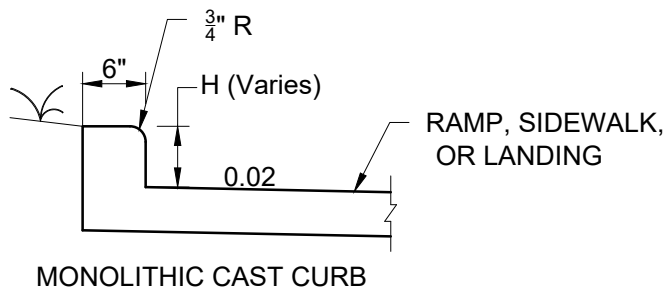

SIDEWALK CURB OPTIONS

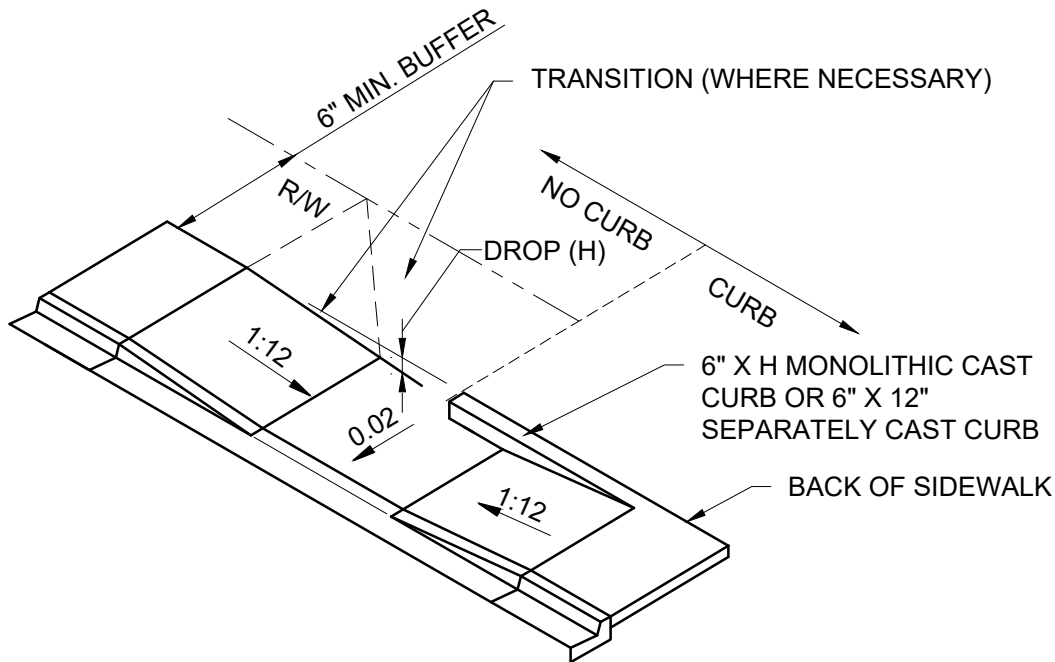

CONSTRUCT SIDEWALK CURB IN CUT SECTIONS

SIDEWALK CURB



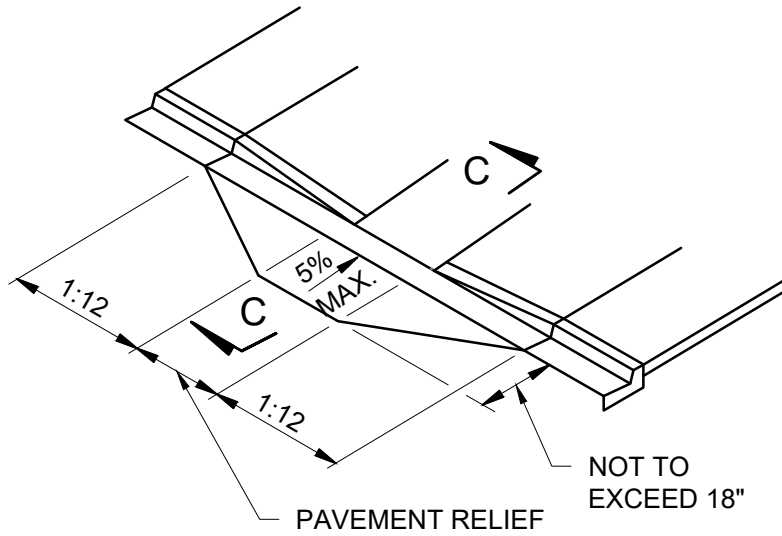

PICTORIAL VIEW

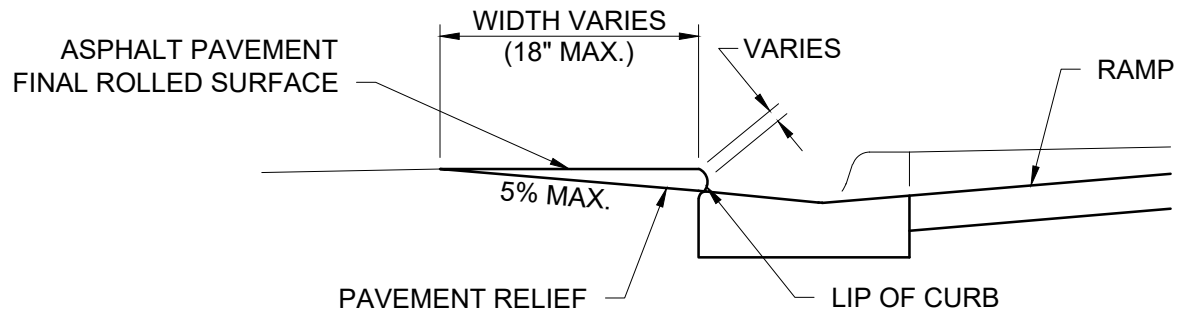

NOTE: REMOVE ELEVATED PAVEMENT BY SPADING AND ROLLING; SMOOTH MILLING; OR GRINDING

SECTION C-C

PAVEMENT RELIEF AT LIP OF CURB



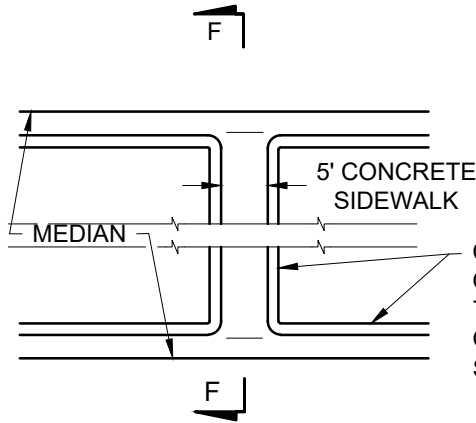

PLAN VIEW

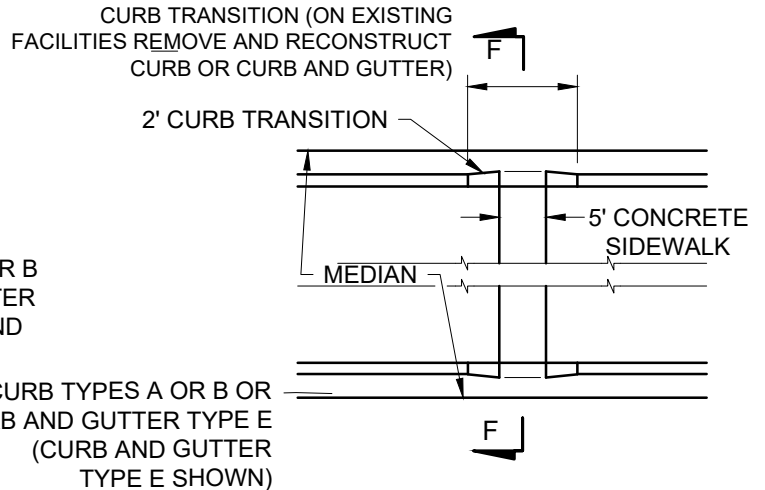

**PLAN VIEW -
(ALTERNATE DETAIL)**

5' REFUGE WITH MAXIMUM SLOPE OF 0.02 MUST BE PROVIDED WHEN SLOPES OF 0.05 OR FLATTER AND 5' IN LENGTH ARE NOT AVAILABLE ALONG THE CROSSWALK; THE REFUGE CAN BE CONSTRUCTED AT ANY LOCATION WITHIN THE CROSSWALK; OR, A 5' X 5' CONCRETE LANDING WITH MAXIMUM SLOPE OF 0.02 CAN BE CONSTRUCTED ADJACENT TO THE CROSSWALK.

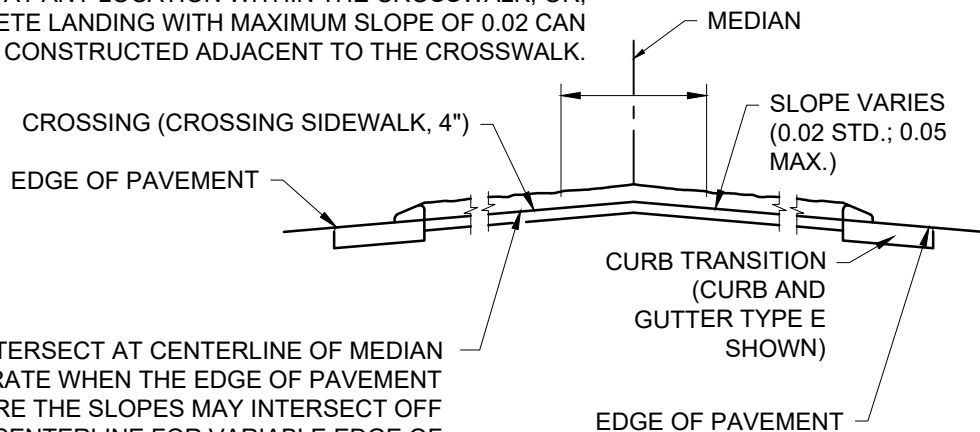

SLOPES TO INTERSECT AT CENTERLINE OF MEDIAN FOR THE 0.02 RATE WHEN THE EDGE OF PAVEMENT ELEVATIONS ARE THE SLOPES MAY INTERSECT OFF THE CENTERLINE FOR VARIABLE EDGE OF PAVEMENT ELEVATIONS OF TO ACCOMMODATE OTHER CONSTRUCTION IN THE MEDIAN; SLOPES ARE NOT TO BE STEEPER THAN 0.05.

**SECTION F-F
MEDIAN REFUGE**

MEDIAN CROSSING



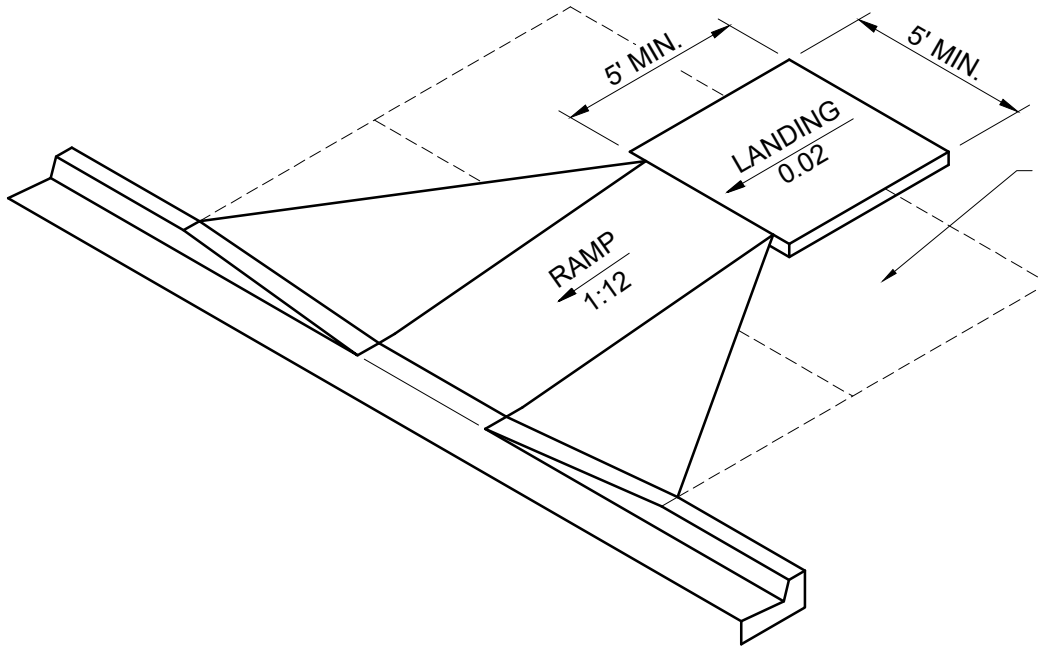

OTHER OPTIONS AS SHOWN IN THE PLANS

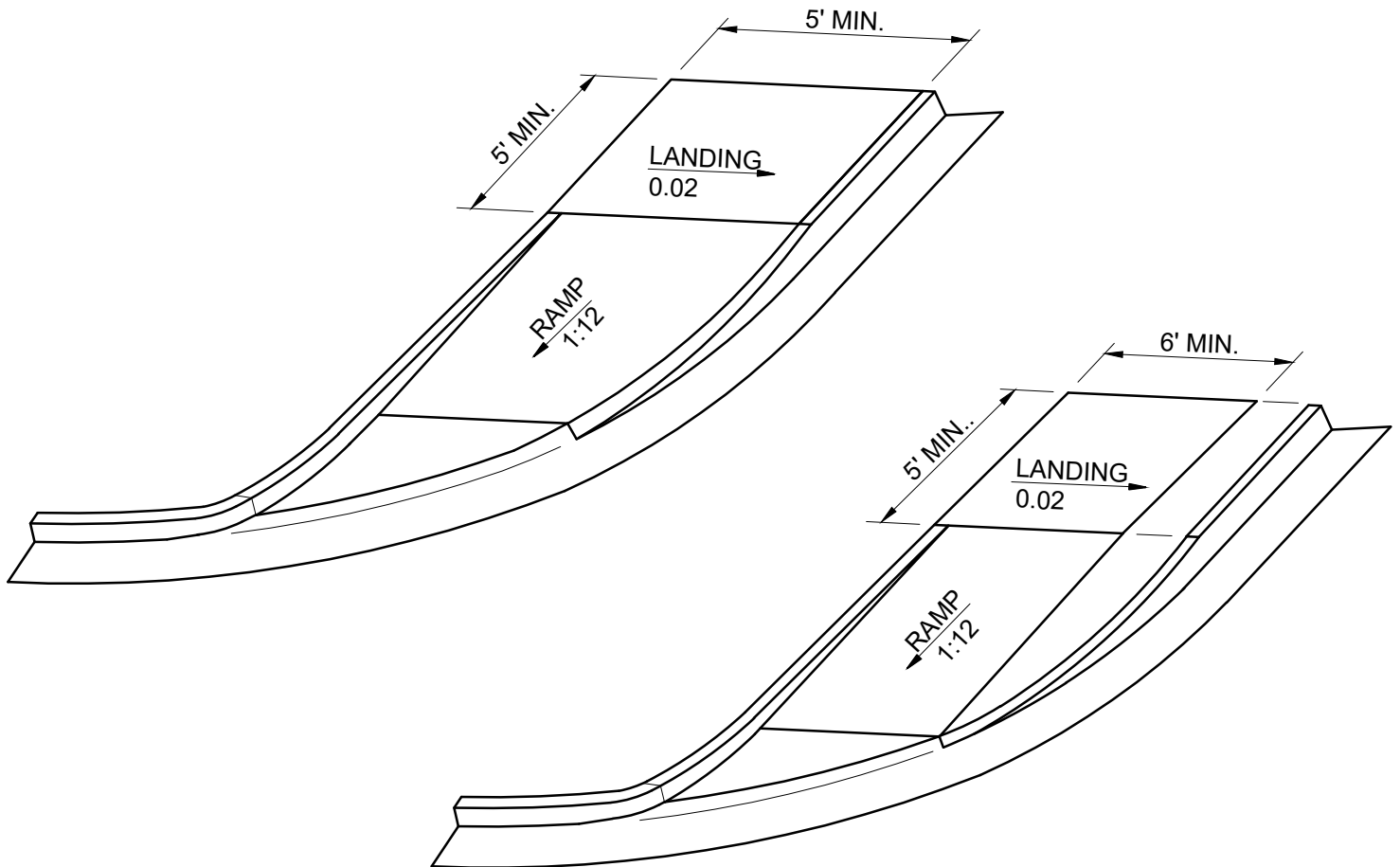

LANDINGS FOR CURB RAMPS WITHOUT SIDEWALKS



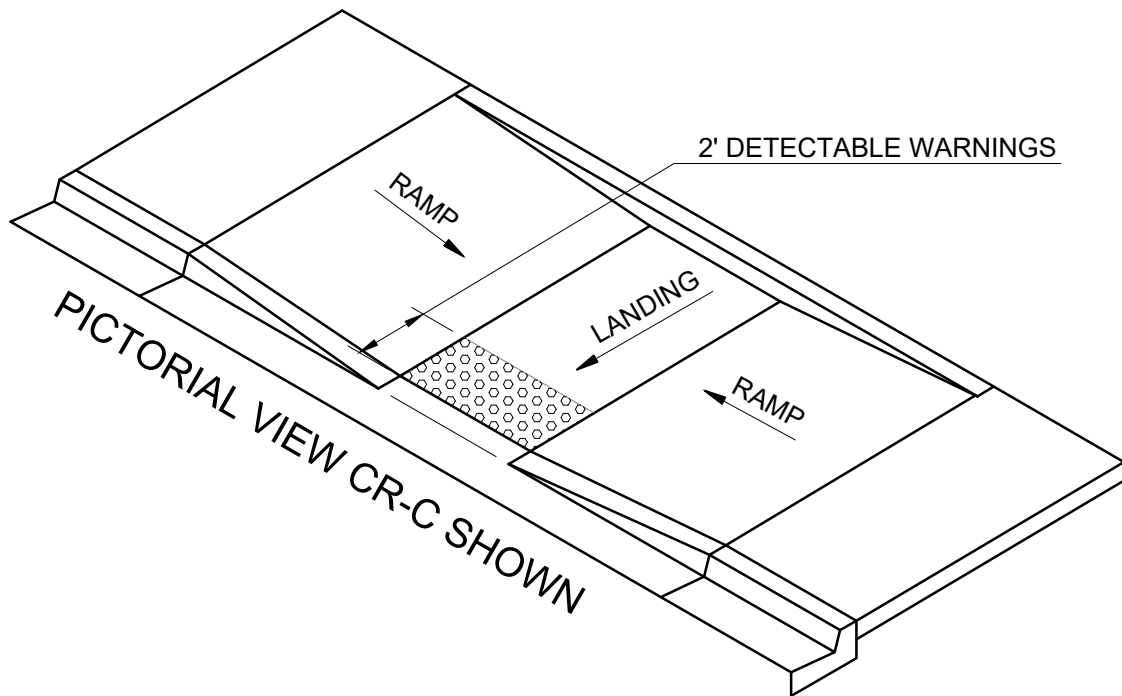
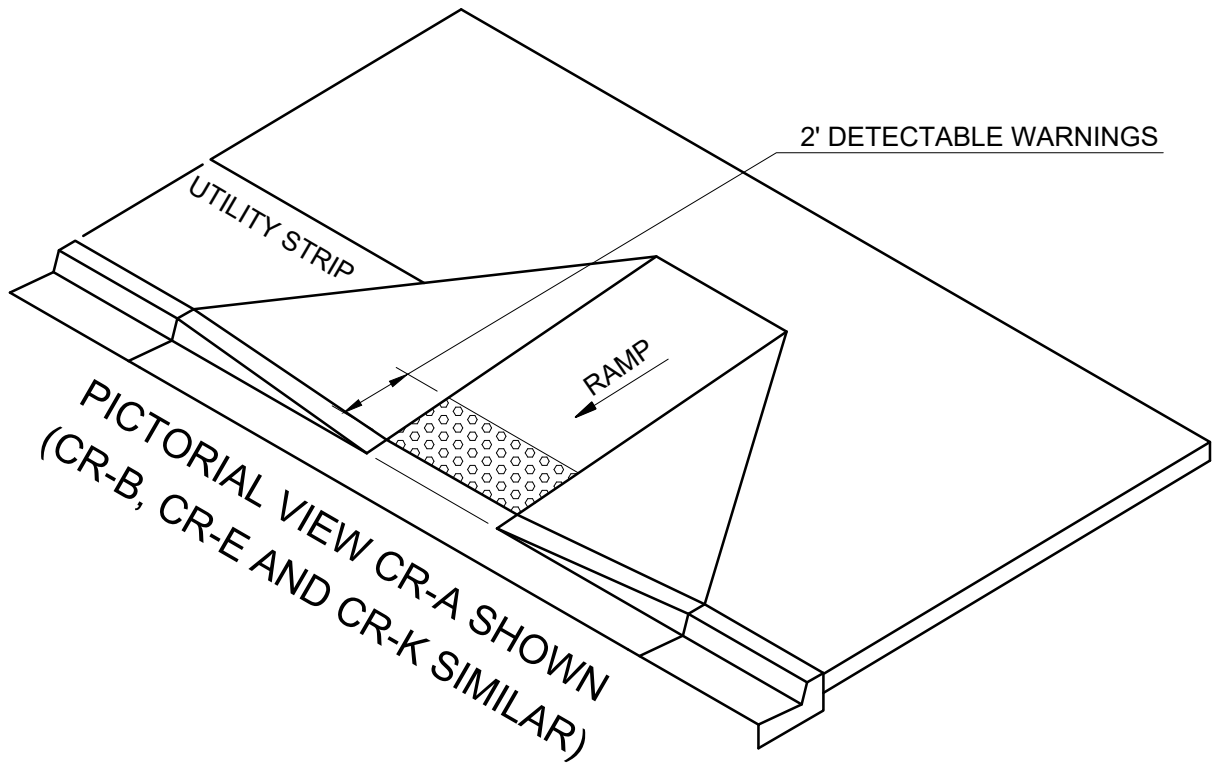

TYPICAL PLACEMENT OF DETECTABLE WARNINGS



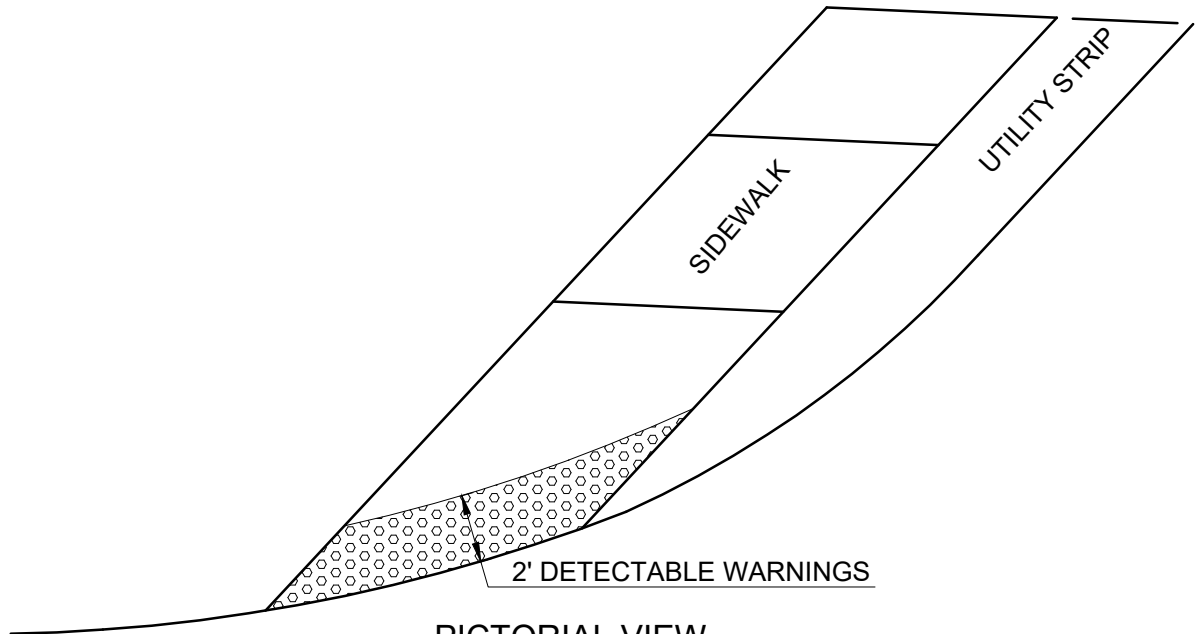

PICTORIAL VIEW
FLUSH SHOULDER
(OPTION A)

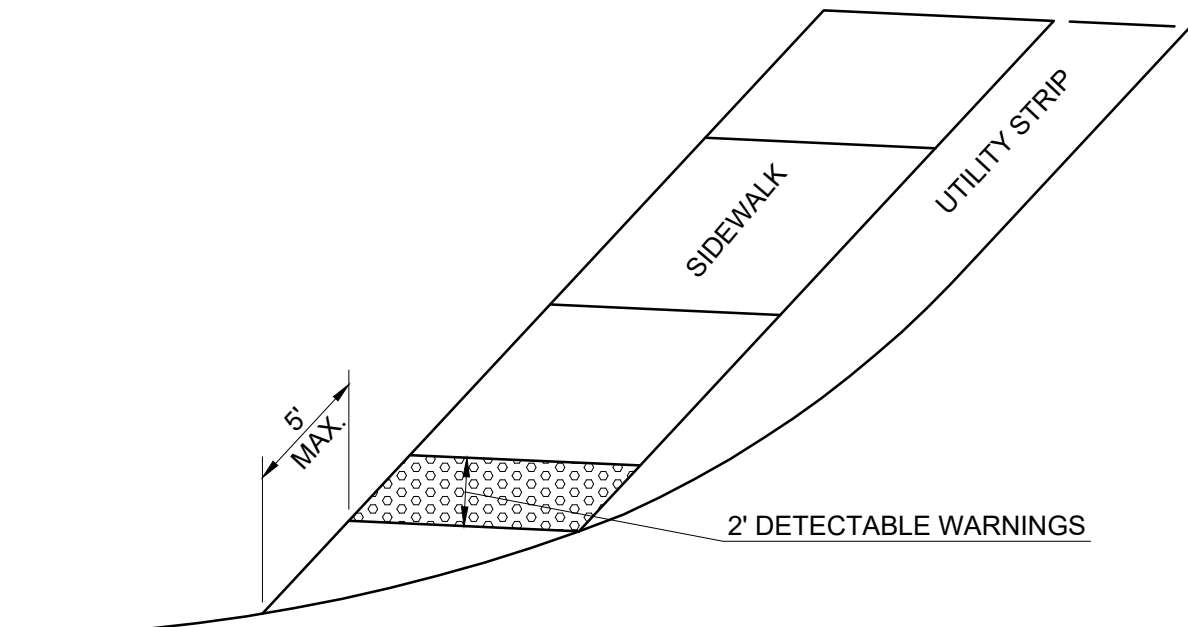

PICTORIAL VIEW
FLUSH SHOULDER
(OPTION B)

TYPICAL PLACEMENT OF DETECTABLE WARNINGS



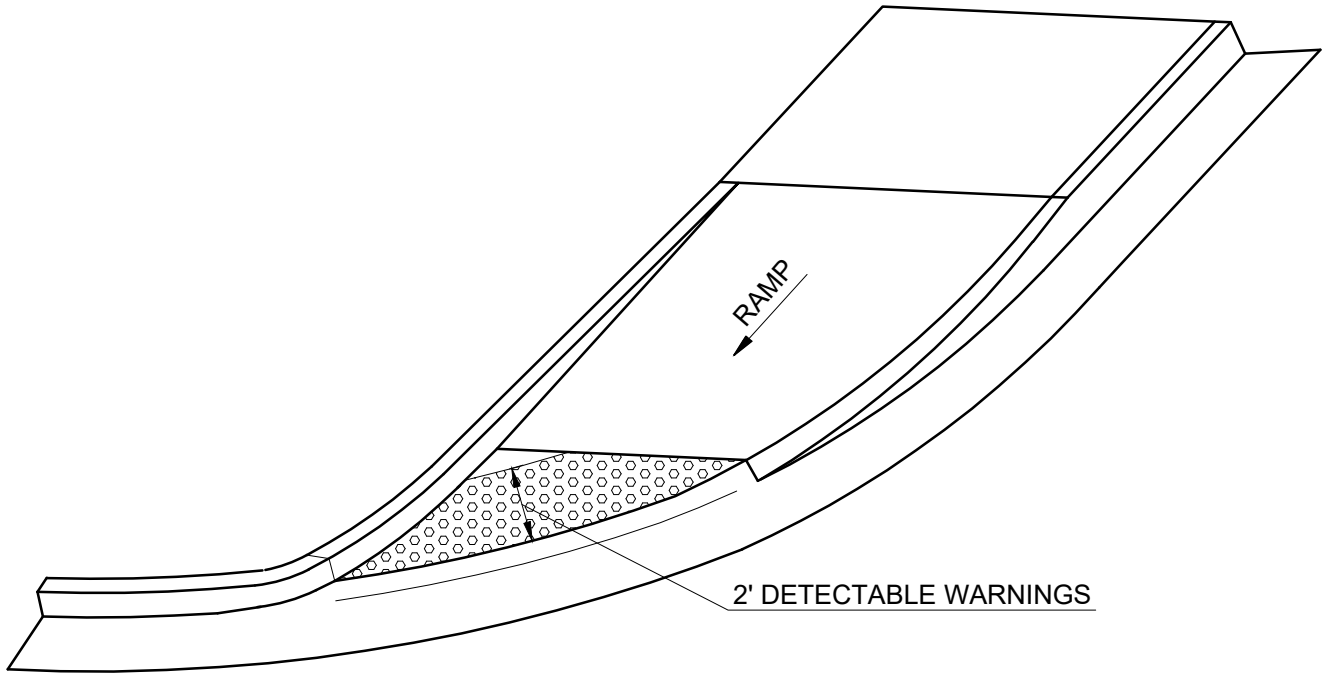

PICTORIAL VIEW CR-G SHOWN
(OPTION A) (CR-F AND CR-H SIMILAR)

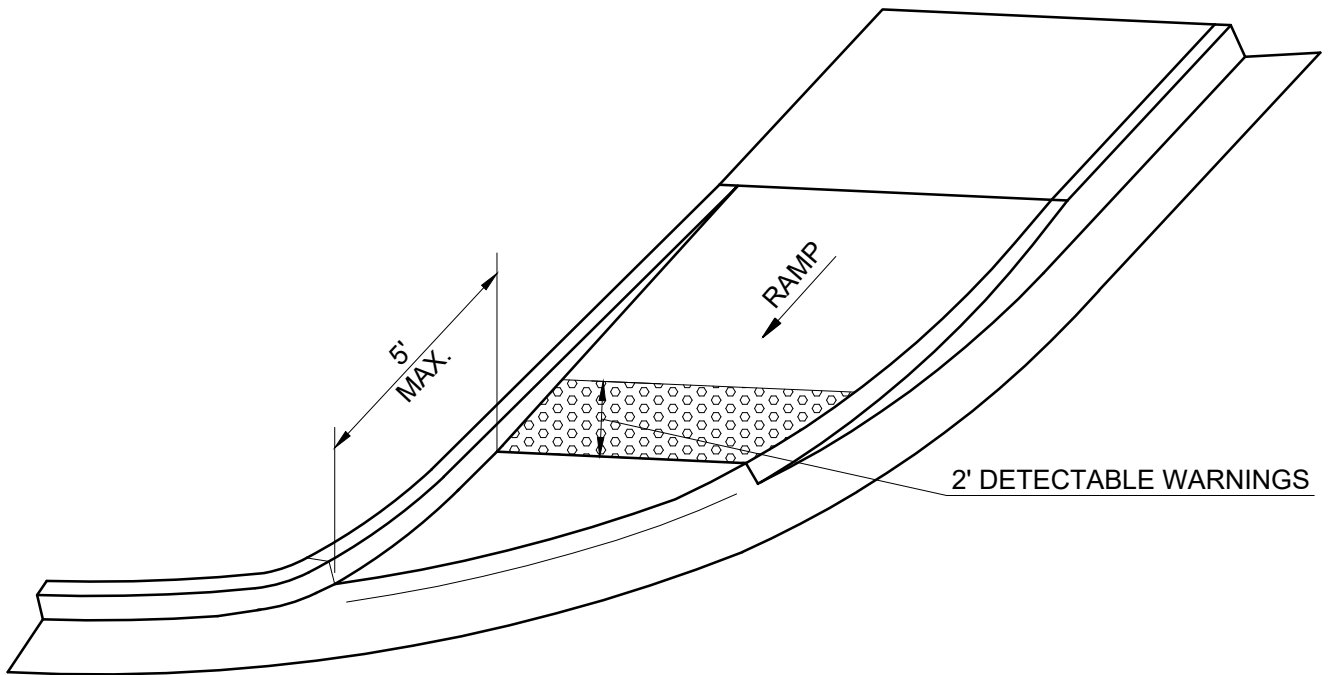

PICTORIAL VIEW CR-G SHOWN
(OPTION B) (CR-F AND CR-H SIMILAR)

TYPICAL PLACEMENT OF DETECTABLE WARNINGS



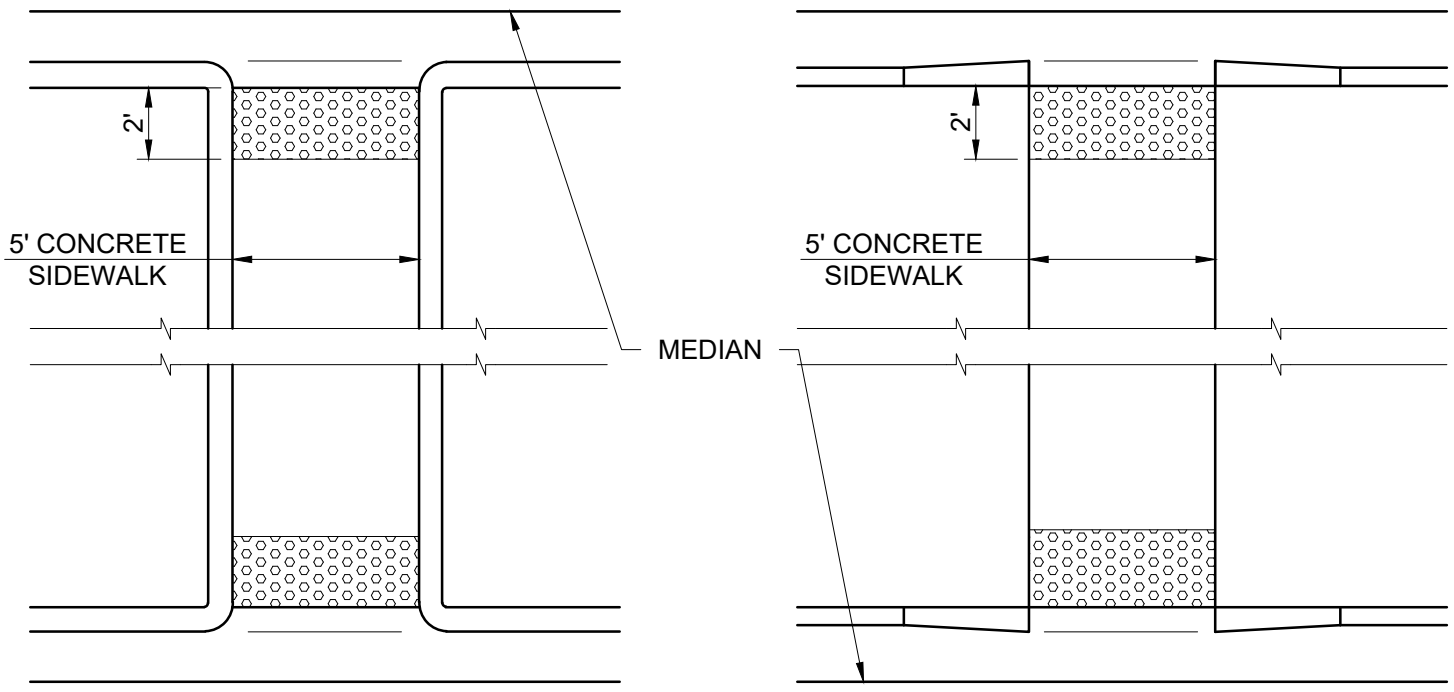

PLAN VIEW

PLAN VIEW - (ALTERNATE DETAIL)

MEDIAN CROSSING

TYPICAL PLACEMENT OF DETECTABLE WARNINGS

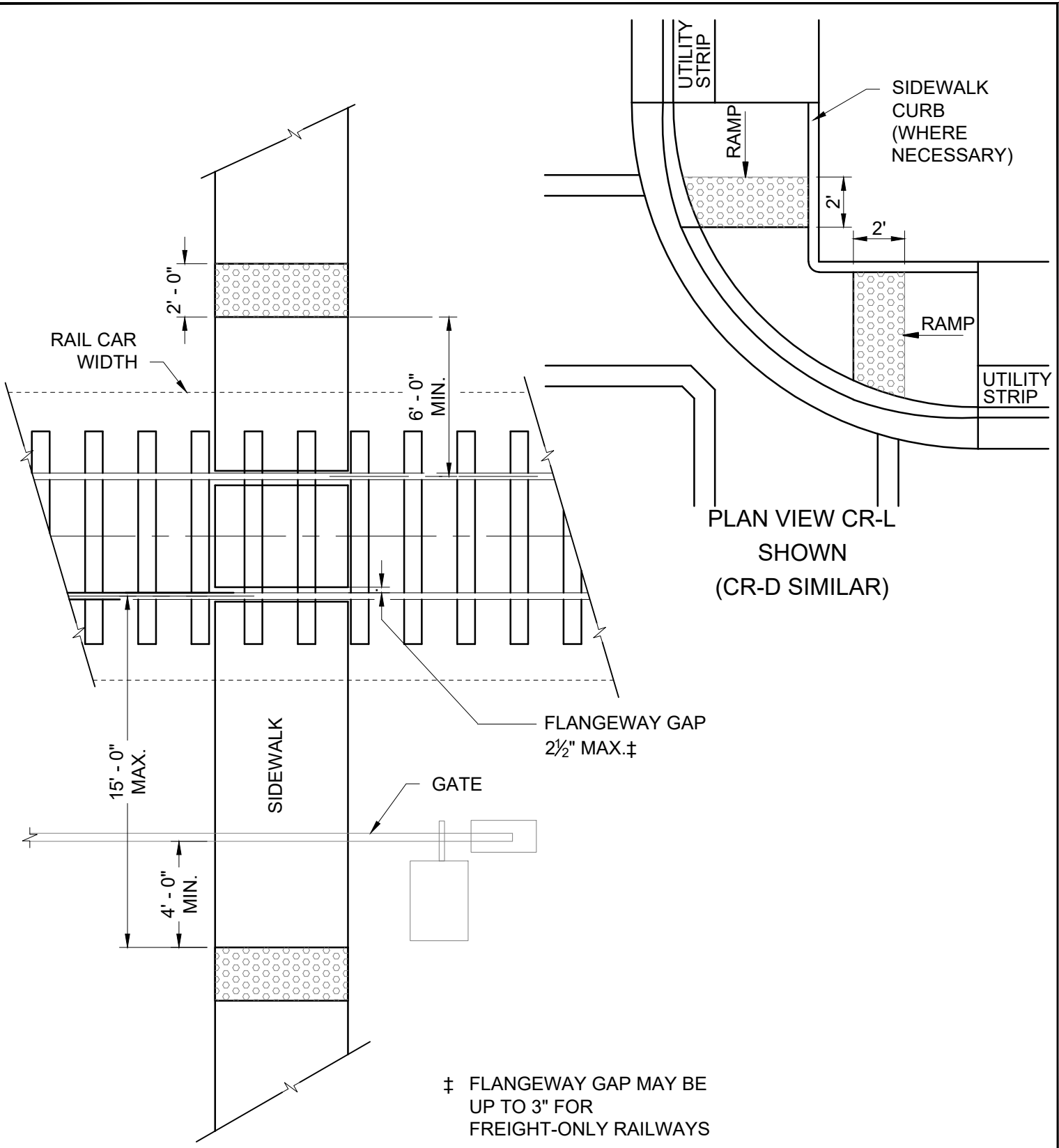

PLAN VIEW RAILROAD CROSSING

TYPICAL PLACEMENT OF DETECTABLE WARNINGS

**TABLE OF DETECTABLE
WARNINGS**

CURB RAMP TYPE	CURB RADIUS (FT)	TOTAL AREA (SF)
CR-A	N/A	8
CR-B	N/A	8
CR-C	N/A	8
CR-D	25	11
CR-E	N/A	8
CR-F	10	9
	20	11
	25	13
	30	14
CR-G	10	10
	20	11
	25	12
	30	14
CR-H	20	8
	25	8
	30	8
CR-K	N/A	8
CR-L	10	18
	15	13
FLUSH SHOULDER		
OPTION A	10	11
	20	14
	25	15
	30	17
	40	19
OPTION B	50	21
	10	10
	20	10
	25	10

NOTE:

DUE TO CONSTRUCTION APPLICATIONS, CR-L IS THE ONLY CURB RAMP FOR WHICH A DETECTABLE WARNING QUANTITY WAS CALCULATED USING A CURB RADIUS OF 15'.

FOR FLUSH SHOULDER OPTIONS WITH 5' SIDEWALKS, THE BACK OF SIDEWALK IS MEASURED AT 10' FROM THE EDGE OF TRAVELED WAY.

**AREAS OF DETECTABLE WARNINGS FOR SIDEWALK
CURB RAMP AND FLUSH SHOULDER APPLICATIONS**



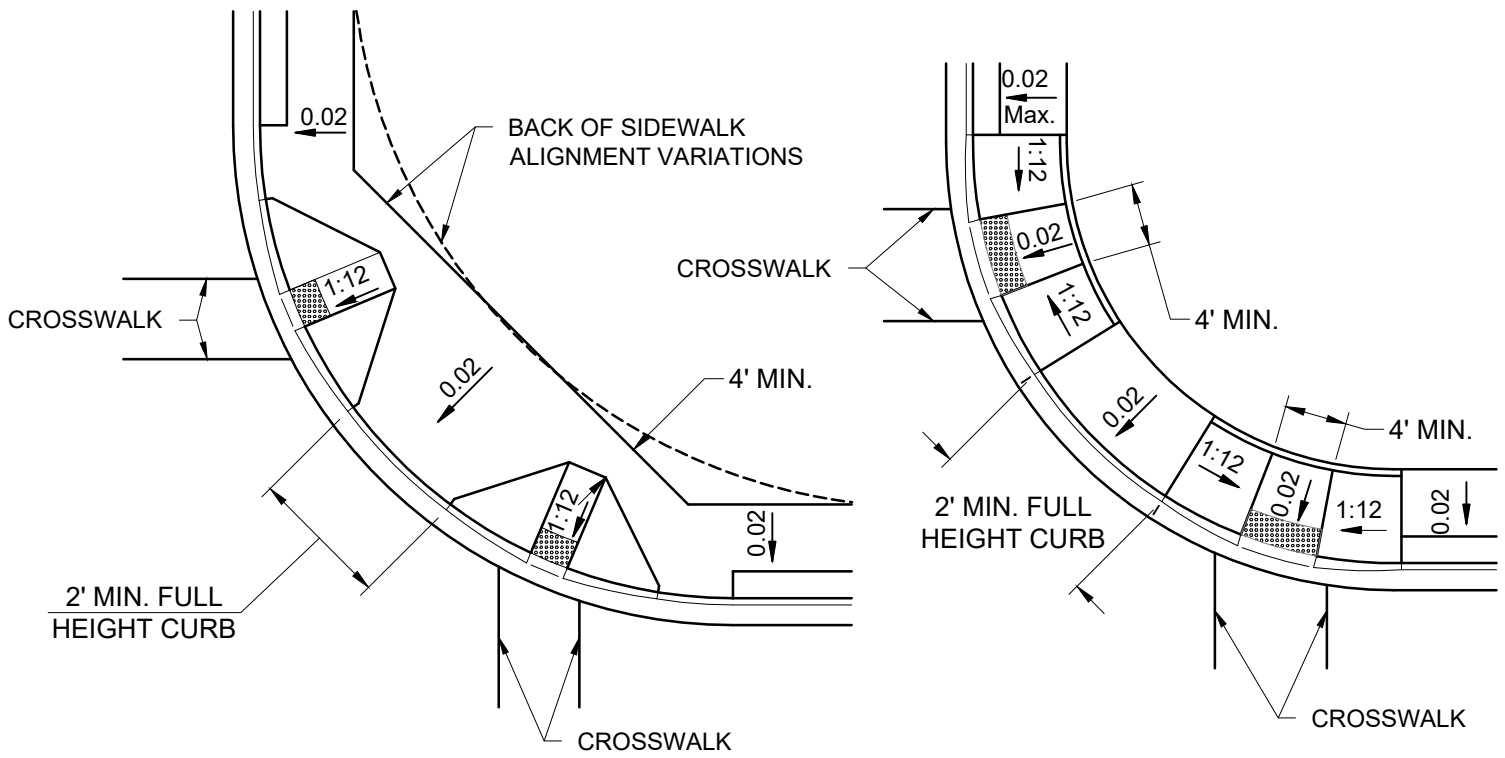

RADIAL SIDEWALK RAMPS

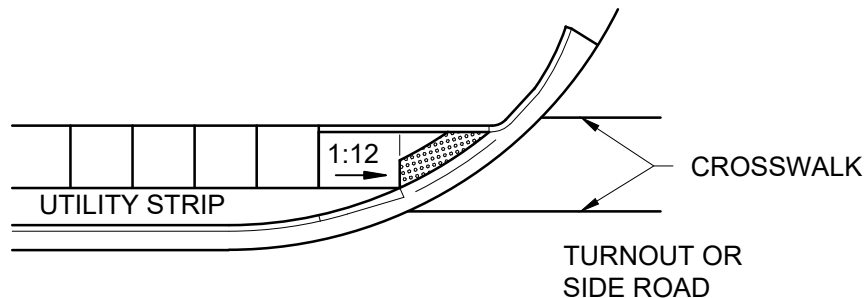

LINEAR SIDEWALK RAMPS

NOTES:

1. WHERE CROSSWALK MARKINGS ARE USED, RAMPS SHALL FALL WITHIN THE CROSSWALK LIMITS. A CLEAR SPACE OF 48" MINIMUM IS REQUIRED AT THE BOTTOM OF THE RAMP WITHIN A MARKED CROSSWALK. IF CROSSWALK MARKINGS ARE NOT PRESENT, A CLEAR SPACE OF 48" MINIMUM IS REQUIRED AT THE BOTTOM OF THE RAMP OUTSIDE OF ACTIVE TRAVEL LANES.
2. CROSSWALK WIDTHS AND CONFIGURATIONS VARY; MUST CONFORM TO INDEX NO. 17344 AND 17346.

TYPICAL PLACEMENT OF SIDEWALK CURB RAMPS AT CURBED RETURNS



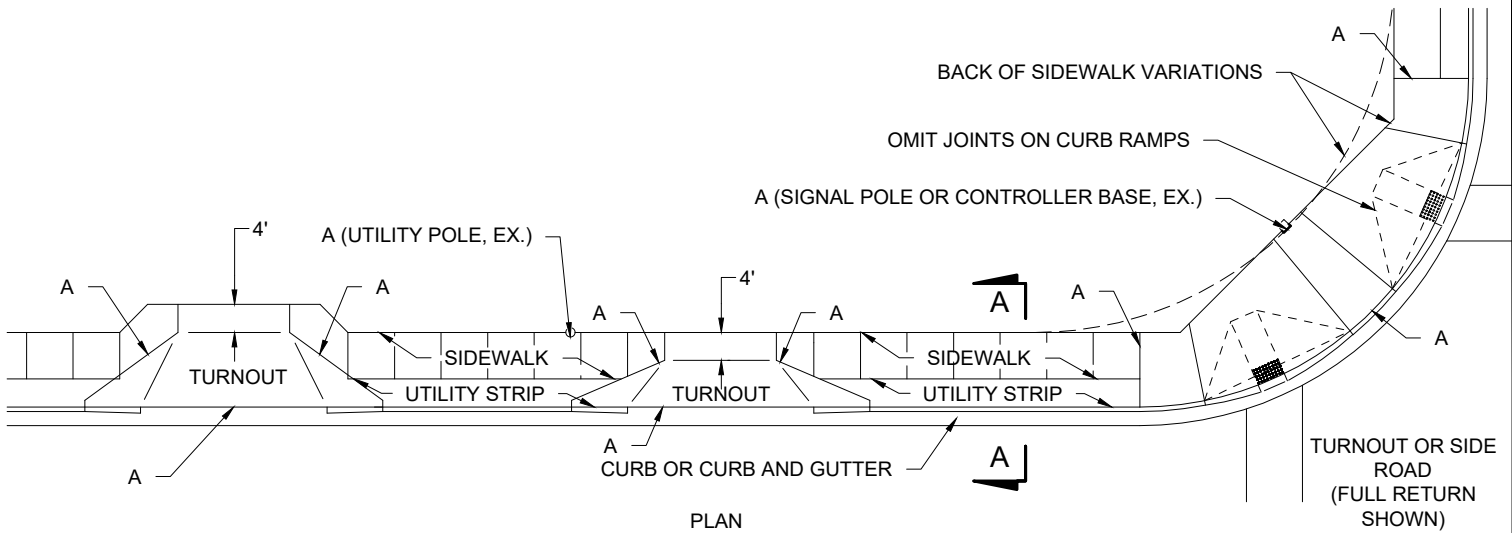

PLAN
SIDEWALK WITH UTILITY STRIP

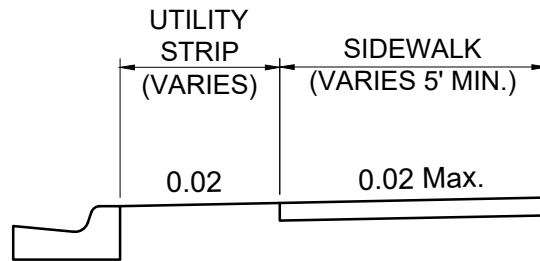

SECTION AA

NOTES FOR CONCRETE SIDEWALK ON CURBED ROADWAYS

1. CONSTRUCT SIDEWALKS IN ACCORDANCE WITH SPECIFICATION SECTION 522.
2. INCLUDE DETECTABLE WARNINGS ON SIDEWALK CURB RAMPS AND CONSTRUCT IN ACCORDANCE WITH INDEX NO. 304.
3. DETECTABLE WARNINGS ARE NOT REQUIRED WHERE SIDEWALKS INTERSECT URBAN FLARED TURNOUTS.
4. BOND BREAKER MATERIAL CAN BE ANY IMPERMEABLE COATED OR SHEET MEMBRANE OR PREFORMED MATERIAL HAVING A THICKNESS OF NOT LESS THAN 6 MILS NOR MORE THAN 1/2".
5. FOR TURNOUTS SEE INDEX NO. 515.
6. CONSTRUCT SIDEWALKS WITH 1' THICK EDGE BEAM THROUGH THE LIMITS OF ANY SURFACE MOUNTED PEDESTRIAN/BICYCLE PICKET RAILING OR PIPE GUIDERAIL SHOWN IN THE PLANS.

CONCRETE SIDEWALK ON CURBED ROADWAYS



CITY OF FORT LAUDERDALE
PUBLIC WORKS DEPARTMENT
ENGINEERING DETAILS

100 North Andrews Avenue, Fort Lauderdale, Florida 33301

CONCRETE SIDEWALK
SHEET 1

DETAIL NO.
ROAD
035

REVISED:
2017/03/11

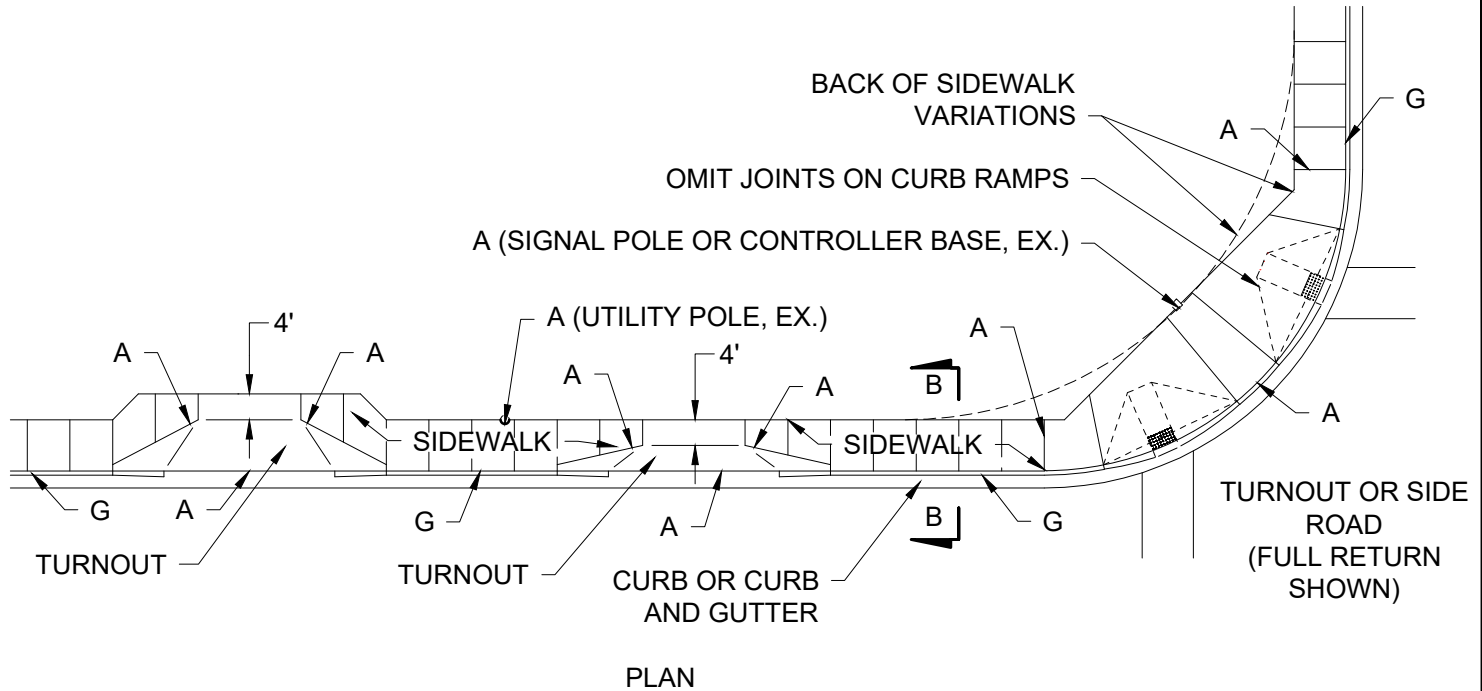

PLAN
SIDEWALK WITHOUT UTILITY STRIP

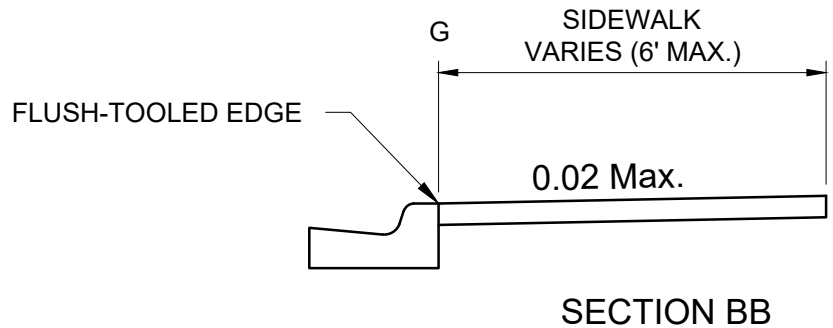

NOTES FOR CONCRETE SIDEWALK ON CURBED ROADWAYS

1. CONSTRUCT SIDEWALKS IN ACCORDANCE WITH SPECIFICATION SECTION 522.
2. INCLUDE DETECTABLE WARNINGS ON SIDEWALK CURB RAMPS AND CONSTRUCT IN ACCORDANCE WITH INDEX NO. 304.
3. DETECTABLE WARNINGS ARE NOT REQUIRED WHERE SIDEWALKS INTERSECT URBAN FLARED TURNOUTS.
4. BOND BREAKER MATERIAL CAN BE ANY IMPERMEABLE COATED OR SHEET MEMBRANE OR PREFORMED MATERIAL HAVING A THICKNESS OF NOT LESS THAN 6 MILS NOR MORE THAN 1/2".
5. FOR TURNOUTS SEE INDEX NO. 515.
6. CONSTRUCT SIDEWALKS WITH 1' THICK EDGE BEAM THROUGH THE LIMITS OF ANY SURFACE MOUNTED PEDESTRIAN/BICYCLE PICKET RAILING OR PIPE GUIDERAIL SHOWN IN THE PLANS.

CONCRETE SIDEWALK ON CURBED ROADWAYS



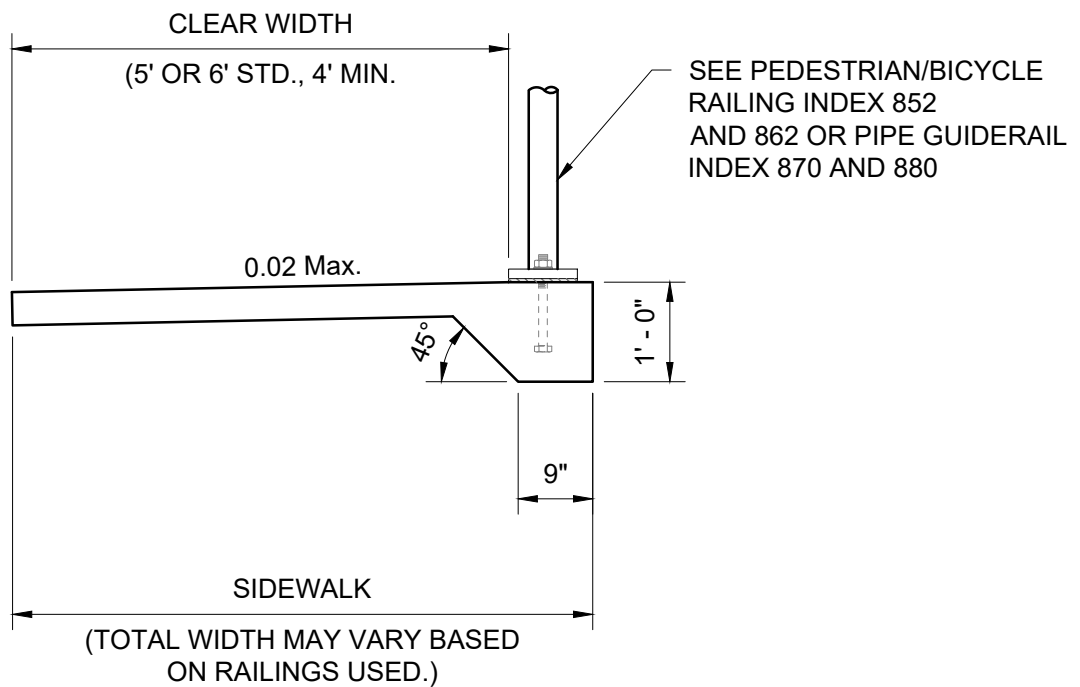

SIDEWALK WITH EDGE BEAM FOR
SURFACE MOUNTED RAILINGS

SIDEWALK WITH EDGE BEAM FOR SURFACE MOUNTED RAILINGS



BASE THICKNESS AND OPTION CODES											
BASE GROUP	STRUCTURAL RANGE	BASE GROUP PAY ITEM NUMBER	Base Options								
			LIMEROCK, LBR 100	CEMENTED COQUINA, LBR 100	SHELL ROCK, LBR 100	BANK RUN SHELL, LBR 100	RECYCLED CONCRETE AGGREGATE, LBR 150 **	GRADED AGGREGATE BASE, LBR 100	TYPE B-12.5	B-12.5 AND 4" GRANULAR SUBBASE, LBR 100 *	RAP BASE
			STRUCTURAL NUMBER (PER. IN.)								
			(0.18)	(0.18)	(0.18)	(0.18)	(0.18)	(0.15)	(0.30)	(0.30 & 0.15)	(NA)
1	0.65-0.75	701	4"	4"	4"	4"	4"	4½"	4"		<input type="checkbox"/> 5"
2	0.80-0.90	702	5"	5"	5"	5"	5"	5½"	4"		
3	0.95-1.05	703	5½"	5½"	5½"	5½"	5½"	6½"	4"		
4	1.05-1.15	704	6"	6"	6"	6"	6"	7½"	4"		
5	1.25-1.35	705	7"	7"	7"	7"	7"	8½"	4½"		
6	1.35-1.50	706	8"	8"	8"	8"	8"	9"	5"		
7	1.50-1.65	707	8½"	8½"	8½"	8½"	8½"	10"	5½"		
8	1.65-1.75	708	9½"	9½"	9½"	9½"	9½"	11"	5½"		
9	1.75-1.85	709	10"	10"	10"	10"	10"	12"	6"	4"	
10	1.90-2.00	710	11"	11"	11"	11"	11"	Ø 13"	6½"	4½"	
11	2.05-2.15	711	12"	12"	12"	12"	12"	Ø 14"	7"	5"	
12	2.20-2.30	712	12½"	12½"	12½"	12½"	12½"		7½"	5½"	
13	2.35-2.45	713	Ø 13½"	Ø 13½"	Ø 13½"	Ø 13½"	Ø 13½"		8"	6"	
14	2.45-2.55	714	Ø 14"	Ø 14"	Ø 14"	Ø 14"	Ø 14"		8½"	6½"	
15	2.60-2.70	715							9"	7"	

* FOR GRANULAR SUBBASE, THE CONSTRUCTION OF BOTH THE SUBBASE AND TYPE B-12.5 WILL BE BID AND USED AS OPTIONAL BASE. GRANULAR SUBBASES INCLUDE LIMEROCK, CEMENTED COQUINA, SHELL ROCK, BANK RUN SHELL, RECYCLED CONCRETE AGGREGATE AND GRADED AGGREGATE BASE. THE BASE THICKNESS SHOWN IS TYPE B-12.5. ALL SUBBASE THICKNESSES ARE 4" MINIMUM.

** FOR RESTRICTIONS ON THE USE OF RECYCLED CONCRETE AGGREGATE - SEE SPECIFICATIONS SECTION 911.

Ø TO BE USED FOR WIDENING, THREE FEET OR LESS.

BASED ON MINIMUM PRACTICAL THICKNESSES.

FOR RESTRICTIONS ON THE USE OF RAP BASE - SEE STANDARD SPECIFICATIONS.

GENERAL NOTES

1. WHERE BASE OPTIONS ARE SPECIFIED IN THE PLANS, ONLY THOSE OPTIONS MAY BE BID AND USED.
2. IN SITUATIONS WHERE THE DESIGNER REQUIRES THE USE OF A SINGLE BASE OPTION, AS SHOWN IN THE PLANS, BID AND USE AS OPTIONAL BASE.



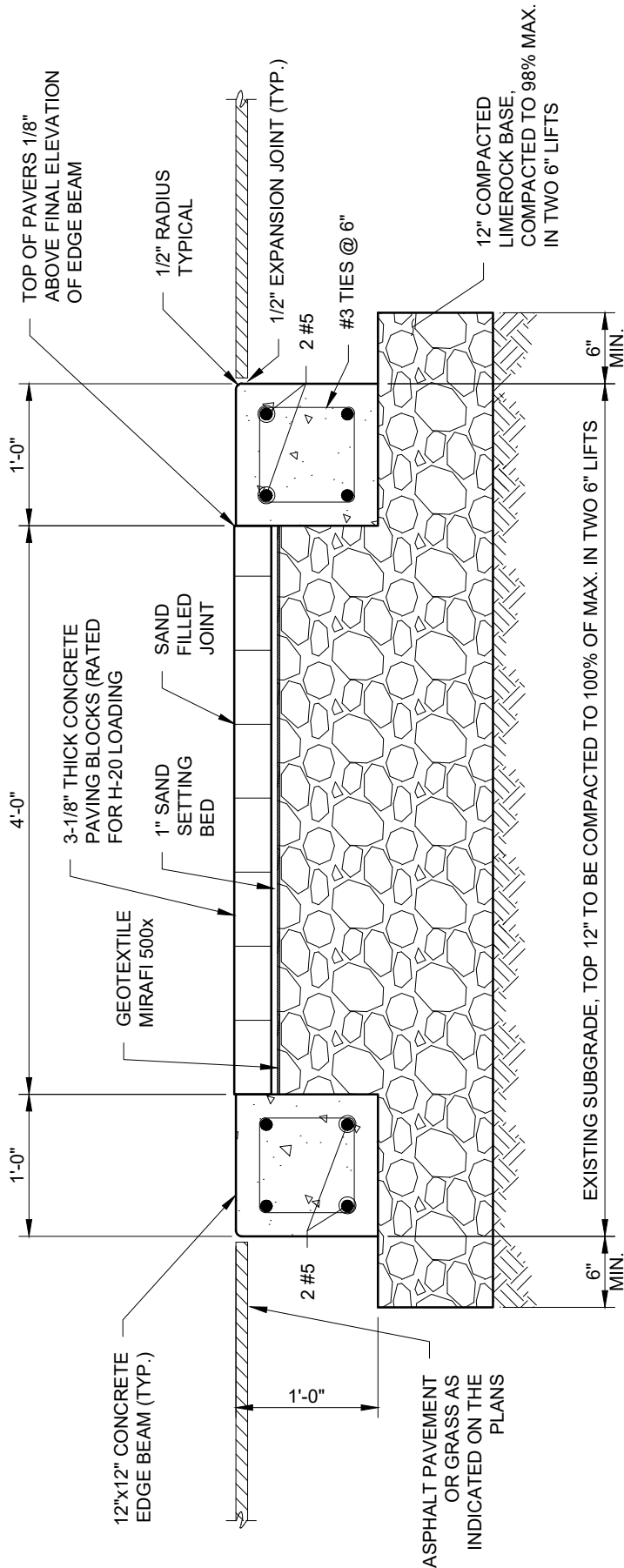

NOTES:

1. CONTRACTOR SHALL GIVE SPECIAL ATTENTION TO ACHIEVE COMPACTION REQUIREMENTS AT AREAS ADJACENT TO EDGE RESTRAINTS, CATCH BASINS, AND UTILITY STRUCTURES.
2. CONTRACTOR SHALL FORM THE INTENDED SURFACE PROFILE OF THE BASE SO THAT THE PAVERS CAN BE PLACED ON A UNIFORM THICKNESS OF BEDDING SAND.
3. SURFACE OF COMPACTED BASE SHALL BE SMOOTH WITH A SURFACE SMOOTHNESS MAXIMUM TOLERANCE OF $\pm 3/8"$ OVER A 10' STRAIGHTEDGE. UNEVEN AREAS OF THE LIMEROCK BASE SURFACE MUST BE MADE LEVEL PRIOR TO PLACING THE BEDDING SAND. BEDDING SAND SHALL NOT BE USED TO COMPENSATE FOR AN UNEVEN BASE.
4. CONTRACTOR SHALL ENSURE THAT ALL SURROUNDINGS CONTAINING EDGES, AND COMPACTED BASE ARE COMPLETED PRIOR TO INITIATING PAVEMENT INSTALLATION.
5. BEDDING SAND SHALL CONFORM TO ASTM C33 (CONCRETE SAND) WITH 0% PASSING No. 200 SIEVE. SPREAD BEDDING SAND AT OPTIMUM MOISTURE CONTENT EVENLY OVER BASE AND SCREED SAND TO AN EVEN THICKNESS OF 1" ($\pm 3/16"$). THE SCREED SAND SHALL NOT BE DISTURBED.
6. LAY PAVERS IN THE PATTERN INDICATED. MAINTAIN STRAIGHT JOINT LINES. JOINTS BETWEEN PAVERS SHALL BE CONSISTENT AND BETWEEN 1/16 TO 1/8 INCH WIDE.

7. AFTER AN AREA OF PAVERS ARE PLACED, IT SHALL BE COMPACTED WITH A VIBRATING PLATE COMPACTOR, EXERTING 5000 LBS. OF CENTRIFUGAL COMPACTION FORCE, WITH SURFACE CLEAN AND JOINTS UNSANDED. A MINIMUM OF THREE PASSES SHALL BE MADE. PLATE VIBRATOR SHALL HAVE A RUBBER MAT OR ROLLER FEET TO AVOID CHIPPING THE PAVERS.
8. JOINT SAND SHALL BE FINER THAN THE BEDDING SAND TO FACILITATE FILLING OF THE JOINTS. THIS CAN BE OBTAINED BY PASSING THE BEDDING SAND THROUGH A No. 8 SIEVE. AFTER THE FIRST PASS OF THE PLATE COMPACTOR, DRY JOINT SAND SHALL BE SWEEPED INTO THE JOINTS AND THE PAVERS COMPACTED. REPEAT THE PROCESS UNTIL THE JOINT ARE FILLED WITH SAND. WET SAND SHALL NOT BE INSTALLED.
9. CONTRACTOR SHALL LEAVE TOP OF PAVERS 1/8" ABOVE FINAL ELEVATION TO COMPENSATE FOR POSSIBLE MINOR SETTLING.
10. ALL CUTS TO BE VERTICAL AND TRUE, NO EDGE PIECE TO BE SMALLER THAN 1/3 FULL PAVEMENT SIZE.
11. GEOTEXTILE WOVEN MIRAFI 500X. FABRIC SHALL BE INSTALLED WITHOUT WRINKLES AND LAPPED 3" AT THEIR EDGES.



CITY OF FORT LAUDERDALE
PUBLIC WORKS DEPARTMENT
ENGINEERING DETAILS

100 North Andrews Avenue, Fort Lauderdale, Florida 33301

DECORATIVE PAVERS
IN ROADWAY

DETAIL NO.
**ROAD
039**

REVISION:
2017/03/11

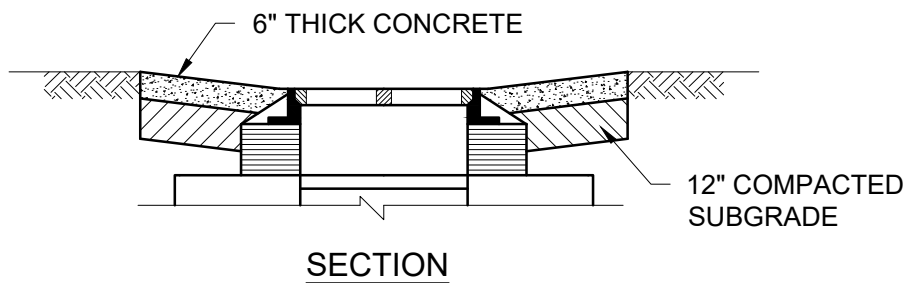
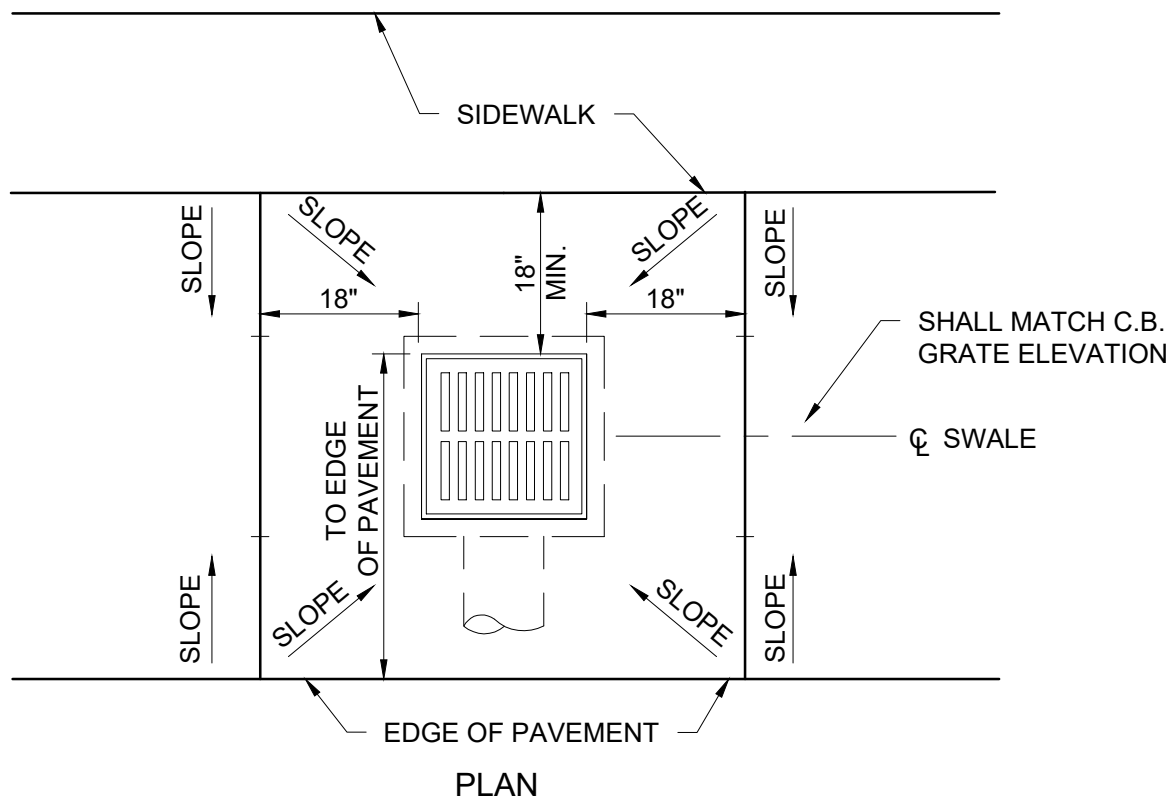

NOTES

1. PAVING AROUND CATCH BASIN TO BE 6" THICK CONCRETE ON COMPACTED SUBGRADE
2. PAVE 18" WIDE (MIN.) APRON ON (3) SIDES. EXTEND FOURTH SIDE TO EDGE OF PAVEMENT.
3. IF DISTANCE FROM BACK OF CATCH BASIN TO FRONT OF SIDEWALK IS 3.0' OR LESS, EXTEND APRON TO FRONT OF SIDEWALK.



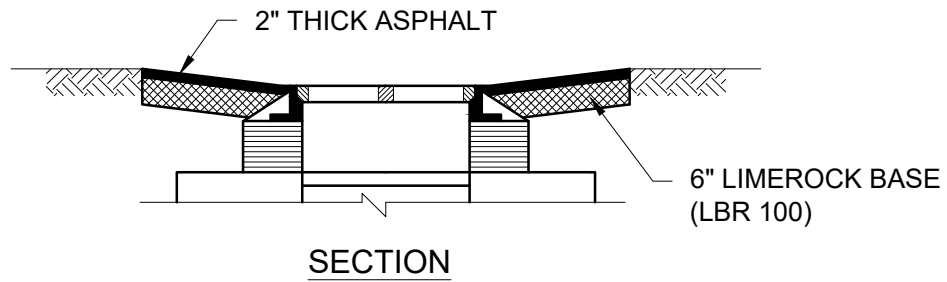
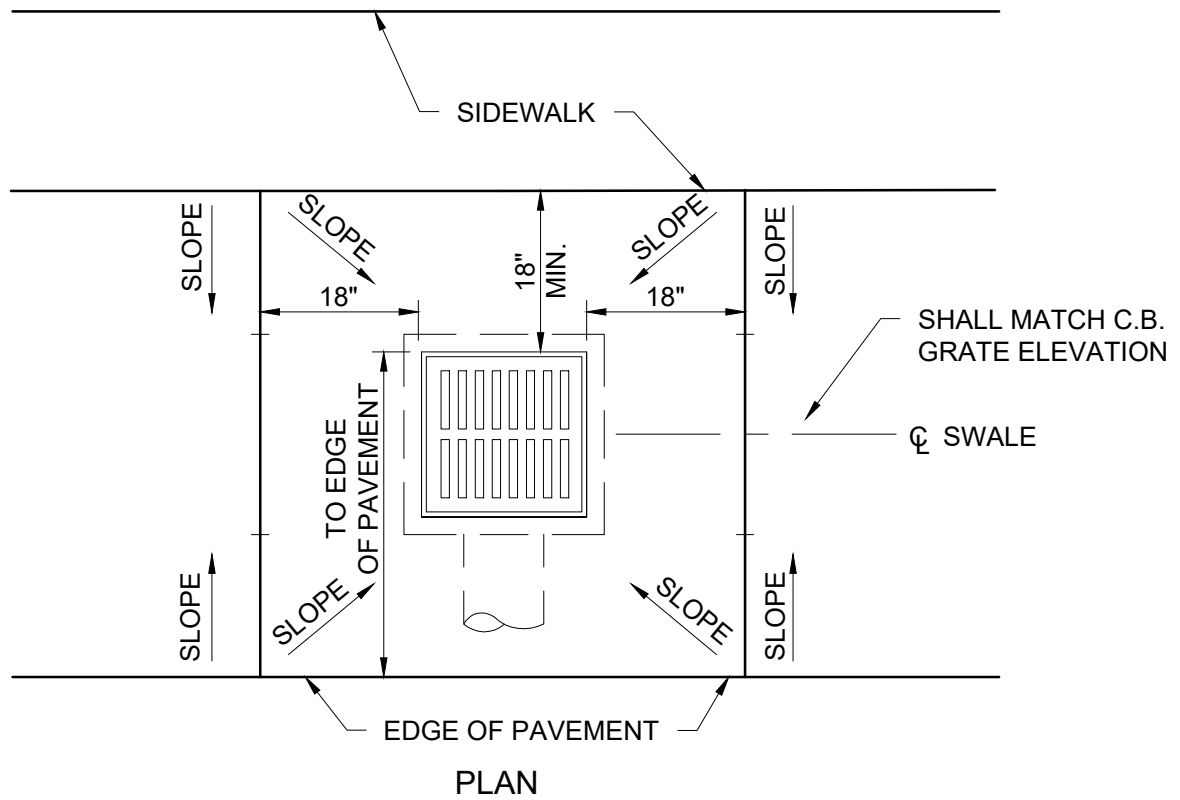

NOTES

1. PAVING AROUND CATCH BASIN TO BE 2" THICK ASPHALT TYPE SP 12.5 ON 6" LIMEROCK BASE (LBR 100).
2. PAVE 18" WIDE (MIN.) APRON ON (3) SIDES. EXTEND FOURTH SIDE TO EDGE OF PAVEMENT.
3. IF DISTANCE FROM BACK OF CATCH BASIN TO FRONT OF SIDEWALK IS 3.0' OR LESS, EXTEND APRON TO FRONT OF SIDEWALK.



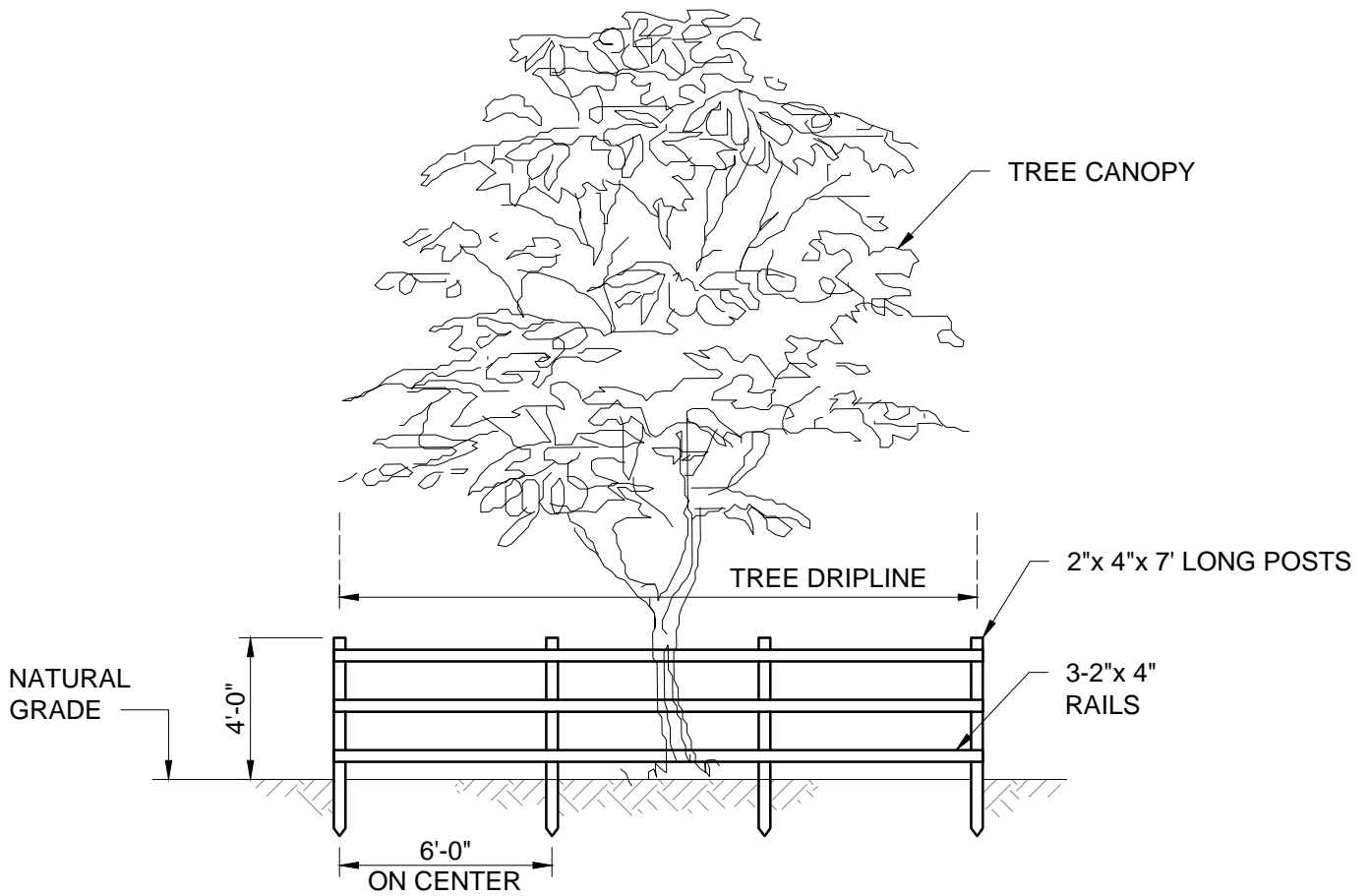

NOTES:

1. BEFORE SITE CLEARING BEGINS PROVIDE NECESSARY MEASURES TO ASSURE SURVIVAL OF VEGETATION.
2. REMOVE BARRIERS AND RESTORE SURFACES PRIOR TO FINAL CLOSEOUT.



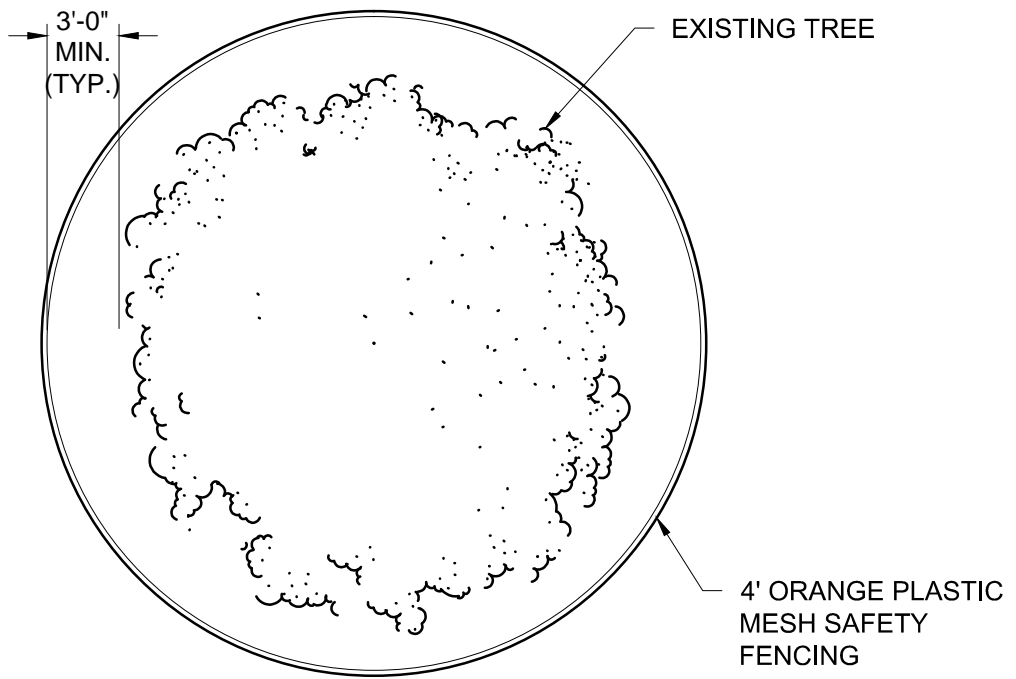

PLAN

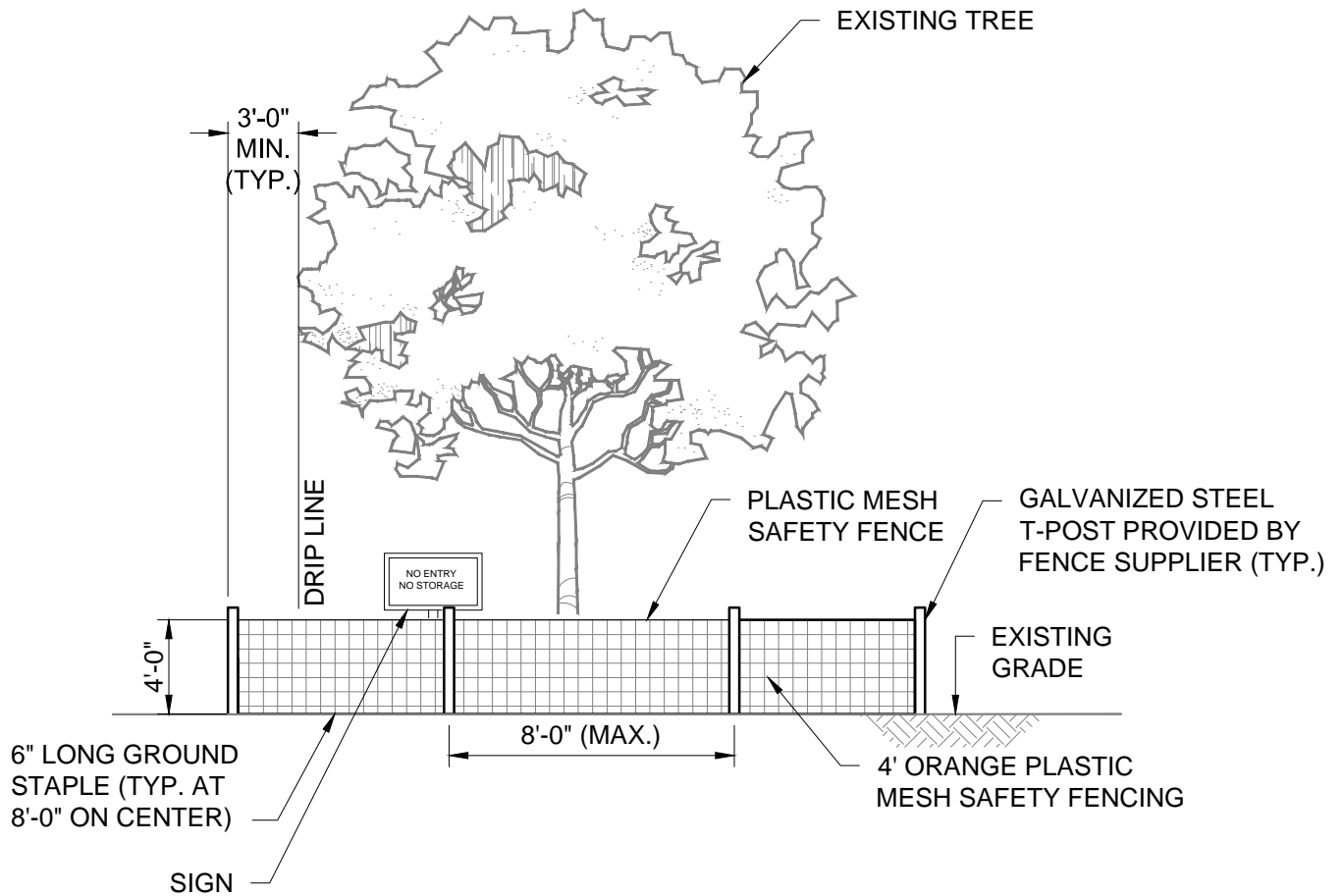

ELEVATION



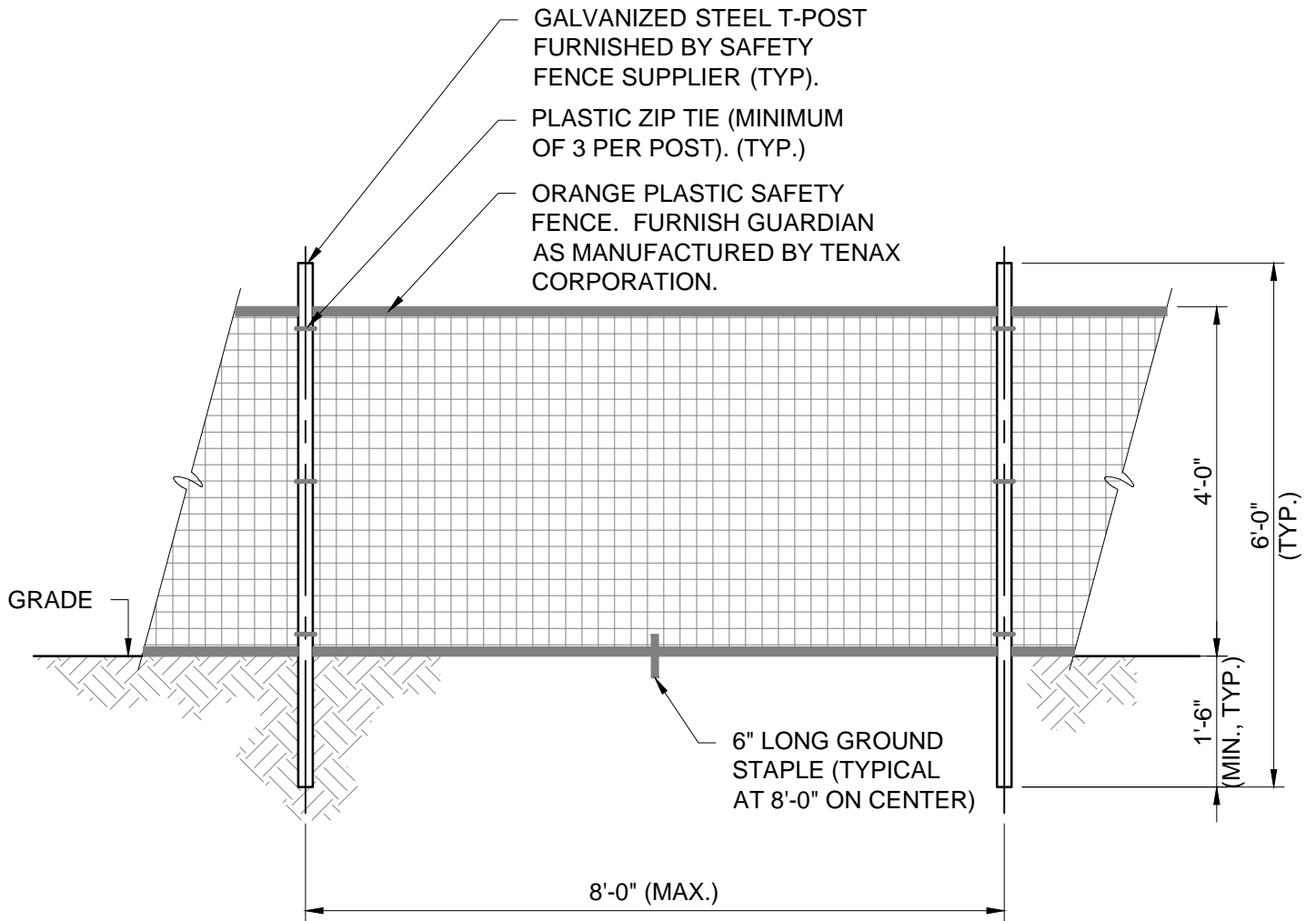

NOTES:

1. REBAR SHALL NOT BE USED FOR SUPPORTING THE FENCE.
2. LOOP THE ZIP TIES THROUGH THE AVAILABLE HOLES OR "TEETH" IN THE POST TO PREVENT THE FENCE FROM SLIDING DOWN THE POST.
3. PLASTIC ZIP TIES SHALL BE AS FOLLOWS:
 - A. MINIMUM WIDTH = 0.3 INCHES.
 - B. LENGTH = AS REQUIRED.
 - C. COLOR = BLACK WITH UV STABILIZER.



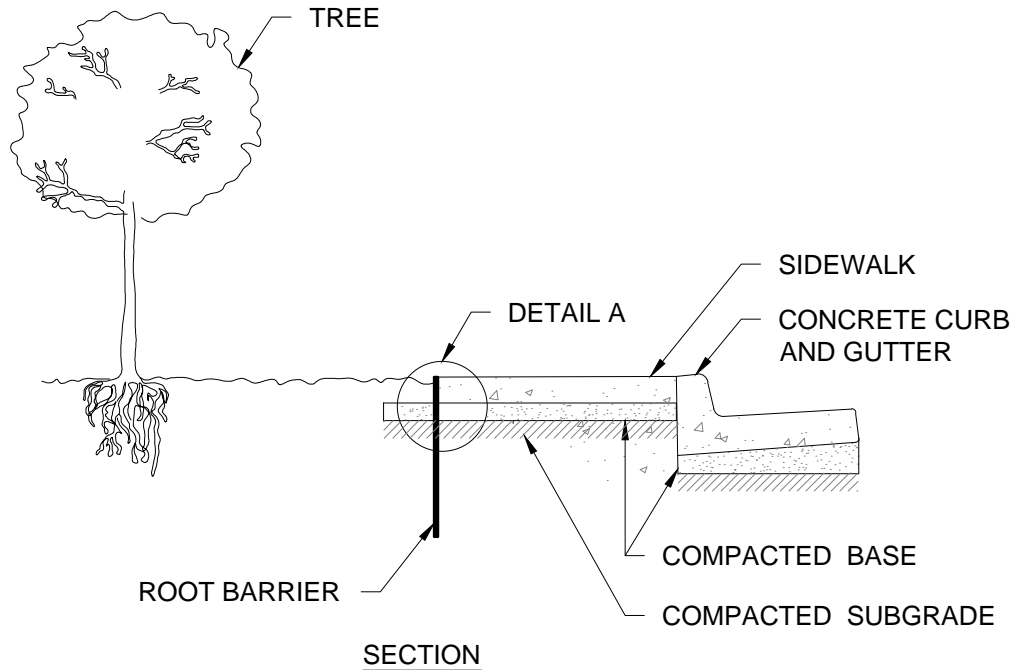

TOP OF ROOT BARRIER 2" BELOW FINISH TOP OF SIDEWALK

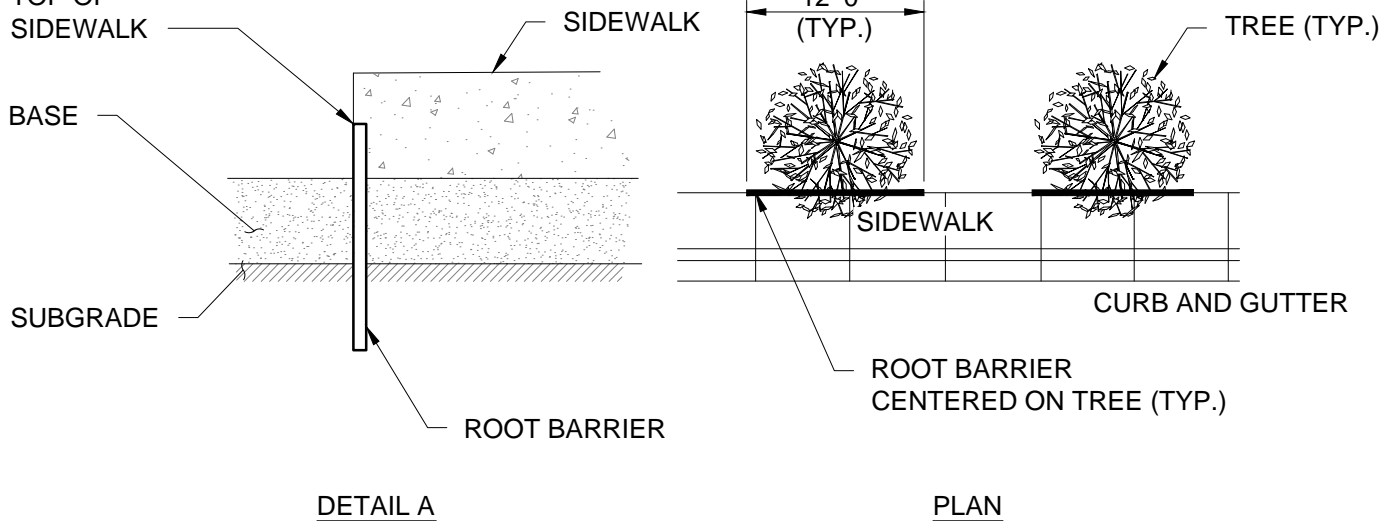

NOTES:

1. ROOT BARRIERS SHALL BE INSTALLED WHEN ROOT BALL IS WITHIN 8'-0" OF SIDEWALK OR AS INDICATED ON THE PLANS.
2. ROOT BARRIER SHALL BE UB 24-2 BY DEEPROOT, OR EQUAL. SUBMIT SHOP DRAWING.
3. TRENCH TO APPROPRIATE DEPTH FOR INSTALLATION OF ROOT BARRIER SO THAT TOP OF BARRIER IS 2" BELOW TOP OF SIDEWALK .
4. PLACE ROOT BARRIER IN TRENCH, VERTICAL RIBS MUST FACE TOWARD TREE ROOTS.
5. BACKFILL AND COMPACT.

