

## PUBLIC ART & PLACEMAKING ADVISORY BOARD MEETING

Monday, August 19, 2024 – 1:00PM  
Tower 101, Suite 1100  
(101 NE 3<sup>rd</sup> Avenue, Fort Lauderdale, FL 33301)

*Roll Call*

*Pledge of Allegiance*

*Approval of Minutes –5/20/2024*

1. Welcome
2. Business for the Arts of Broward Donation at Riverwalk Garage
3. Relocation of Carlos Luna's *Horse* to Las Olas Oceanside Park
4. Project Updates
  - Pepe Gaka Mural at Peter Feldman Park
  - Ernesto Maranje Mural at Holiday Park
  - Timothy Smith Lifeguard Towers
  - Manolo Valdes sculpture at Huizenga Park
  - Dean Davis Mural at Fire Station #49
5. New Business / Board Comments
6. Communications to the Commission
7. Adjournment

*Other items of interest:*

**Purpose:** Advise the City Commission on all matters pertaining to the commissioning, maintenance, acquisition, guidelines and policies of the City's Public Art program and collection.

**Note:**

Two or more City of Fort Lauderdale Commissioners and/or members of a Fort Lauderdale Advisory Board or Committee may be in attendance at this meeting.

If a person decides to appeal any decision made with respect to any matter considered at this public meeting or hearing, he/she will need to ensure that a verbatim record of the proceedings is made, which record includes the testimony and evidence upon which the appeal is to be based.

If you desire auxiliary services to assist in viewing or hearing the meeting or reading agendas and minutes for the meetings, please contact the City Clerk's Office at 954-828-5002 and arrangements will be made to provide these services to you.



Note: In each of the designs, consideration was taken to incorporate architectural elements from the parking garage.



# CHRISTIAN STANLEY

MURALIST

---

## ABOUT THE ARTIST

Christian Stanley is a Central Florida based artist that has lived in the Orlando area since graduating from the University of Central Florida in 2011 with a degree in graphic design. Born and raised in Stuart, Fl., Christian's art is often influenced by his roots and love for the wildlife of the Southeast. From an early age Christian sought out natural settings for inspiration, and continues to enjoy hiking and wildlife spotting with his wife, Jessica.

The two met in 2017 and soon after formed C. Stanley Creative while painting a small electrical box as a part of a community art initiative. Since then Christian has gone on to paint dozens of murals a year with his largest project to date spanning over 8,000 square feet in size. He has taken his mural art talents across the United States and overseas to international street art festivals.

Christian's street art work is known for its signature "dash and dot" style, which borders on impressionism to give his subjects depth and vibrant color. He has had the privilege of working with large national brands and local community arts organizations alike.

In his studio, Christian's work often calls back to the flora and fauna of home, with occasional fantasy or surreal themes. His process involves concepting, digital illustration, and painting with the use of custom made stencils, spray paint, and acrylic paint. Christian has participated in shows and sold original works with ABV Gallery in Atlanta, Georgia.

Christian and Jessica work full time in the arts, and are firm believers in the power of art to change places for the better. In their travels they had the opportunity to see the power of public art at work in communities of all shapes and sizes, and find their most rewarding work to be in towns that understand that art can be used as a tool for community revitalization.

---

# CHRISTIAN STANLEY

## MURALIST

### CONTACT

- 772-285-0979
- cstanleycreative@gmail.com
- www.cstanleycreative.com
- PO Box 195386  
Winter Springs, FL  
32719

### FESTIVALS

- Paint Memphis 2022 & 2021
- Titan Walls Chicago 2022
- Space Coast Mural Festival 2022 (Cocoa Beach, FL)
- Sam Flax Wall Mural Project 2022 & 2019
- Swindon Paint Festival 2023 (United Kingdom)
- SISAF 2023 (Sibiu, Romania)

### EDUCATION

- University of Central Florida**  
Graphic design with a focus on illustration  
Graduated program in 2011

### IN THE NEWS

[The Chicago Sun Times: \*\*For West Loop foundry, artist painted a mural of a fiery gator\*\*](#)

[The Daily City: \*\*Colorful SODO Mural Completed by Local Artist Christian Stanley\*\*](#)

[The Citrus County Chronicle: \*\*Inverness, artists changing direction of Festival of the Arts\*\*](#)

[Art Speak Radio \(Podcast\)](#)

[Channel 13 WIBW News: \*\*25th Mural Being Painted in Clay Center\*\*](#)

[Canvas Rebel: \*\*Meet Christian Stanley\*\*](#)

### ARTIST BIOGRAPHY

Christian Stanley is an Orlando based muralist and illustrator. Having graduated from the University of Central Florida's graphic design program in 2011, his work on large scale murals can be found across the nation and internationally. Raised in Stuart, Florida, Christian's art is influenced by his Florida roots and love for the wildlife of the South. Christian worked for 9 years in large scale graphic design creation and installation before launching C.Stanley Creative LLC. as a professional muralist.

Since the founding of C. Stanley Creative, Christian has been commissioned for large scale works around the country and has been invited as a featured artist to a number festivals including Titan Walls (Chicago), Swindon Fest (United Kingdom), and SISAF (Romania).

### MURALS OF NOTE

*My first mural was painted in the Fall of 2018, and shortly thereafter C. Stanley Creative LLC was formed. Since that time I have painted 1-2 murals per month, with a more comprehensive list of works located on my website (cstanleycreative.com). The follow murals represent a listing of some of my more recent works that I am most proud of.*

#### **Coreopsis**

Winter Park, Florida 2021  
175'x47'

Coreopsis was inspired by the Florida state wildflower. This project is positioned on the interior courtyard of the Alexan WP2 apartment complex. The commission was meant to be peaceful and create a space that felt more natural and organic than the existing concrete wall. Spanning over 7,400 square feet, we completed this wall in about two weeks at the very start of 2021.

#### **Sunflower State of Mind**

2022

Clay Center, Kansas  
80'x30'

Completed in the summer of 2022, this mural resides on the side of Wardcraft Home Store in Clay Center, Kansas. This project was a part of the public art program, A Mural Movement, and was the 25th mural in the series. Featuring the State wildflower (sunflower) and the State bird (Western Meadowlark), this mural was completed with exterior acrylic paint, theme paint, and spray paint.

#### **Chance**

2022

Chicago, Illinois  
52'x22'

Completed in the summer of 2022 as a part of the Titan Walls Mural Festival, this mural resides in the West Loop area of Chicago on the side of the Universal Electric Foundry building. The mural was completed in five days using a combination of exterior latex paint and spray paint.

#### **Lemonade**

2022

Las Vegas, Nevada  
12'x25'

Completed in the summer of 2022, this mural resides on the side of Conrad West Art Gallery in the heart of the Las Vegas Arts District. Spanning over two walls, Christian was able to use the angle to create a distorting effect and cause the corner to virtually disappear within the artwork. This mural was completed with the use of exterior acrylic paint and spray paint.

# CHRISTIAN STANLEY

## MURALIST

### CONTACT

-  772-285-0979
-  cstanleycreative@gmail.com
-  www.cstanleycreative.com
-  631 Dolphin Rd.  
Winter Springs, FL 32708

### GALLERIES

- ABV Gallery, Atlanta Georgia
- Meaty Graffiti, Memphis, Tennessee
- City Arts Factory, Orlando, Florida
- Studio Art Farm, Orlando, Florida
- The Space Station, Orlando, Florida
- The Falcon Gallery, Orlando, Florida
- Cafe TuTu Tango, Orlando, Florida

### SEE OUR WORK

- <https://www.instagram.com/cstanleycreative/>
- <https://www.facebook.com/cstanleycreative/>
- <https://www.youtube.com/@cstanleycreative/featured>
- <https://www.tiktok.com/@cstanleycreative>

### MURALS OF NOTE

#### *Green Lady* 2022

Memphis, Tennessee  
52'x22'

This mural was a part of the Paint Memphis Mural Festival. Our design was inspired by the Celtic legend and imagery of the Green Man. We placed a twist on this idea and instead painted this figure of nature as a woman, symbolizing growth and rebirth. Using brilliant colors of exterior acrylic and spray paint this project was completed in about five days.

#### *Wave* 2023

Jacksonville Beach, Florida  
15x125'

Completed in the spring of 2023, this mural resides just two blocks from the Jacksonville Beach Pier. This project was a part of the public art program, with the City of Jacksonville Beach, and was the first publicly funded mural of their program. Featuring a flurry of sting rays and sea turtles this mural was completed with exterior acrylic paint, theme paint, and spray paint.

#### *Wolf* 2023

Lenox, Massachusetts  
30x12'

This mural was designed to be inline with the branding of Antimony Brewing. It is located on an exterior wall that faces the nearby highway, greeting visitors as they turn toward the establishment. This mural was one of four areas on the property that I painted for Antimony Brewing, with the other three being interior and similar in theme.

#### *Snowy Egret* 2023

Orlando, Florida  
125'x65'

Completed in the spring of 2023 this massive wall resides not far from downtown Orlando on the side of the Alexan Mills Apartment complex parking garage. The client requested a modern, clean, and abstract take on our local wildlife. This project was completed in approximately 3 weeks with use of masonry sealer, and exterior grade acrylic paint.

#### *Vernal Equinox* 2023

Sibiu, Romania  
30'x50"

Completed in the summer of 2023 this mural was a part of the Sibiu International Street Art Festival in Romania. This project was completed in approximately 5 days with use of spray paint and a boom lift.

#### *Water Buffalo* 2023

Swindon, United Kingdom  
20'x9'

Completed in the summer of 2023 this mural was a part of the Swindon Paint Fest in England. This project was completed in approximately 2 days with use of spray paint.



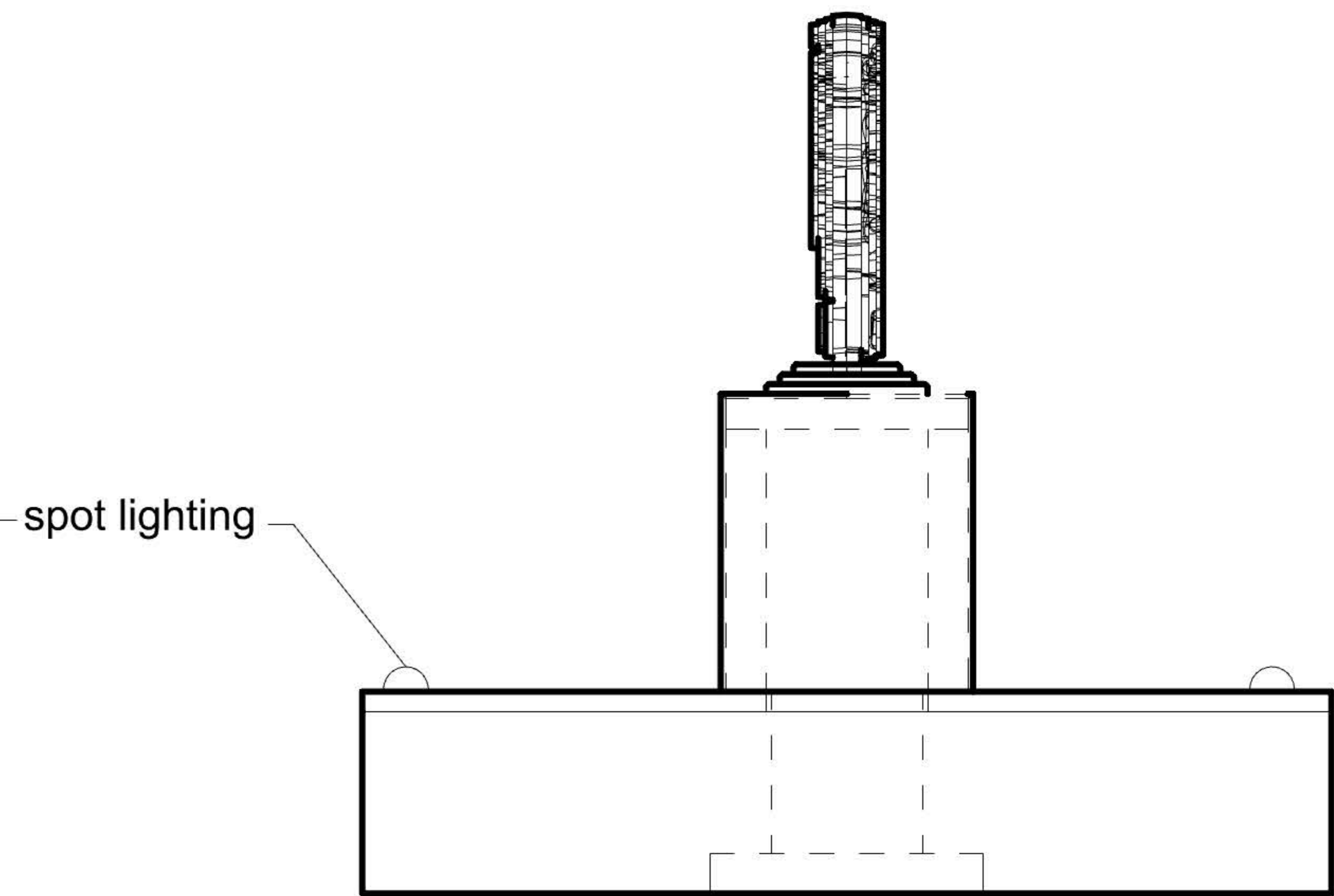
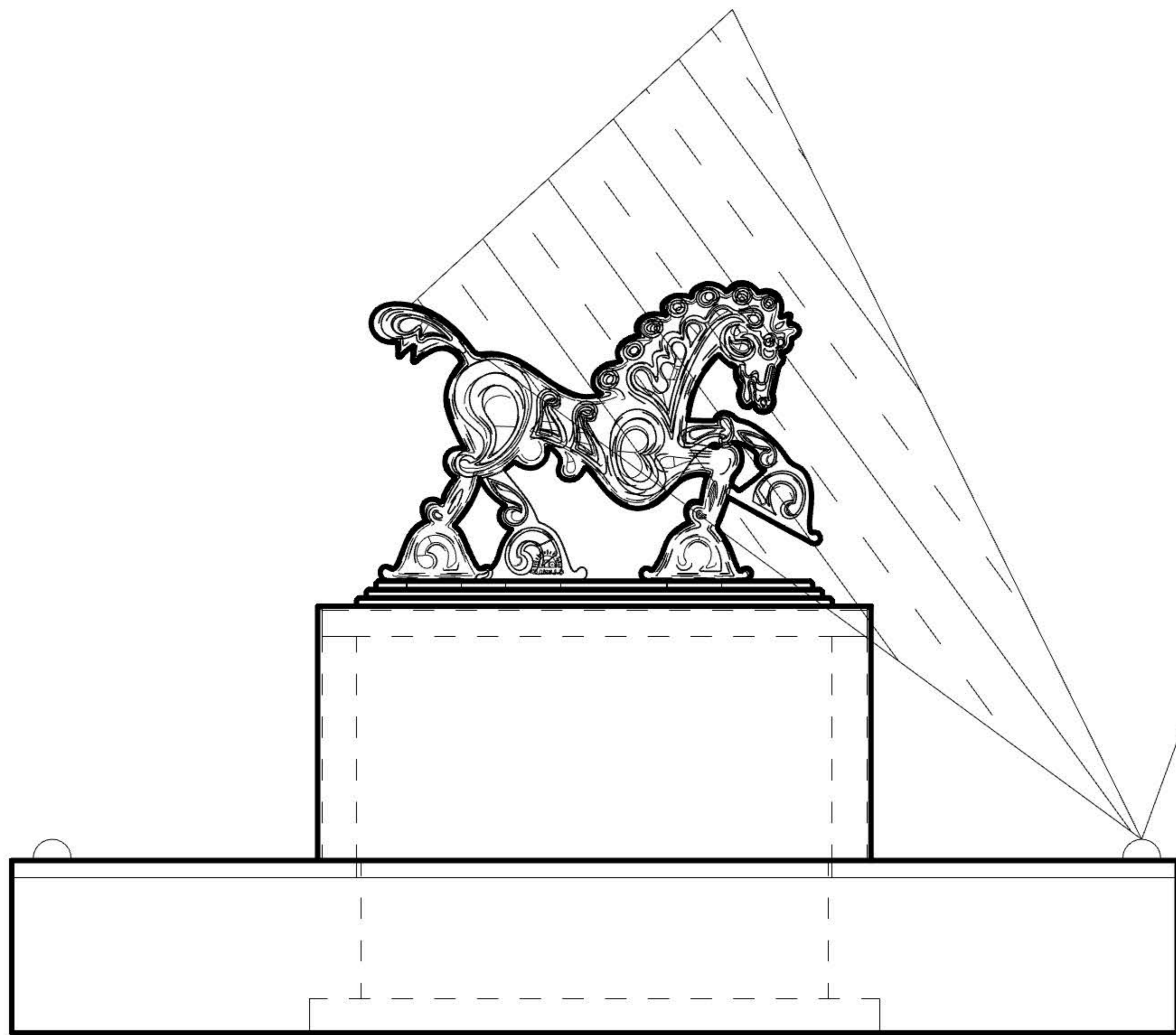
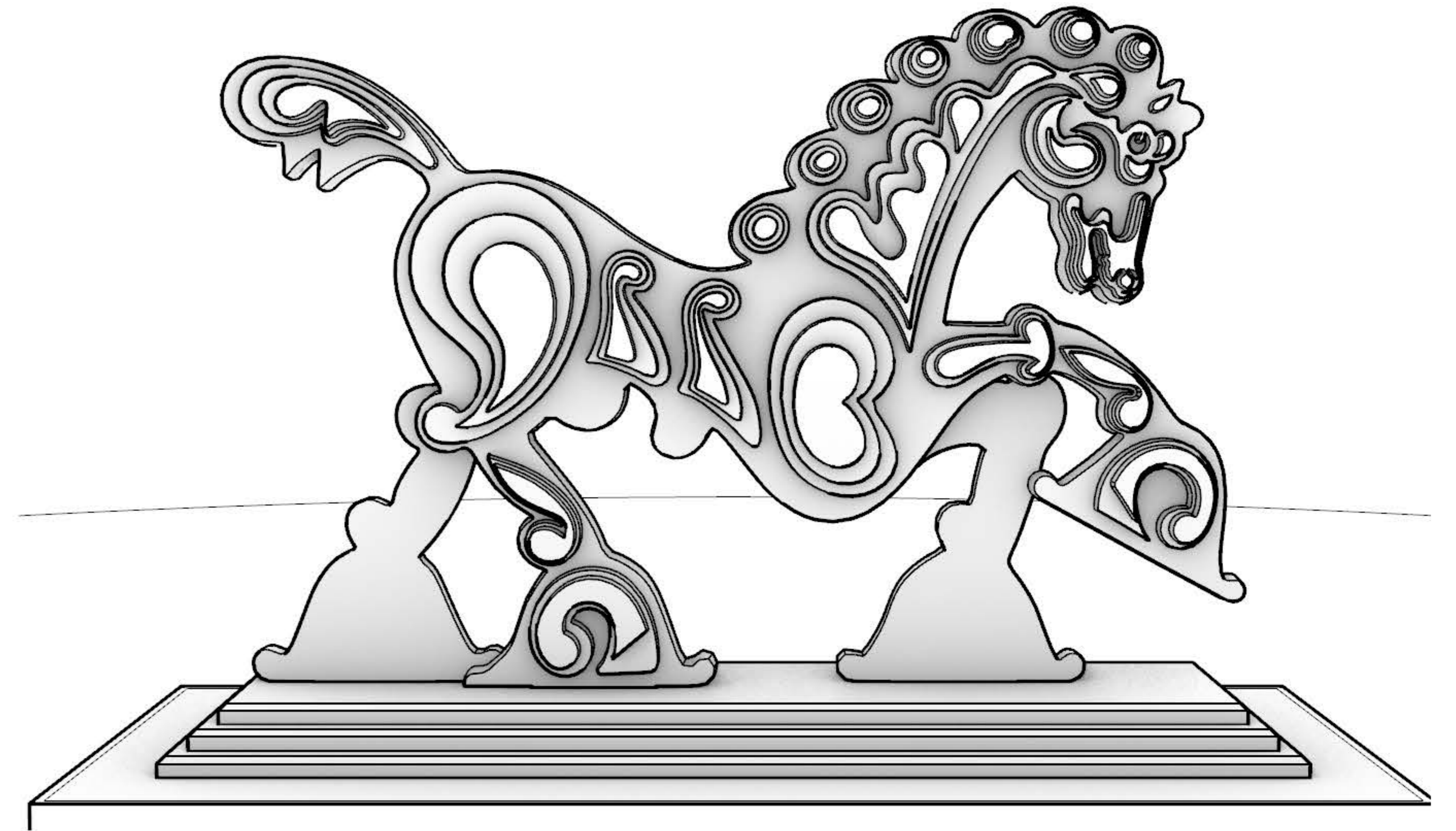
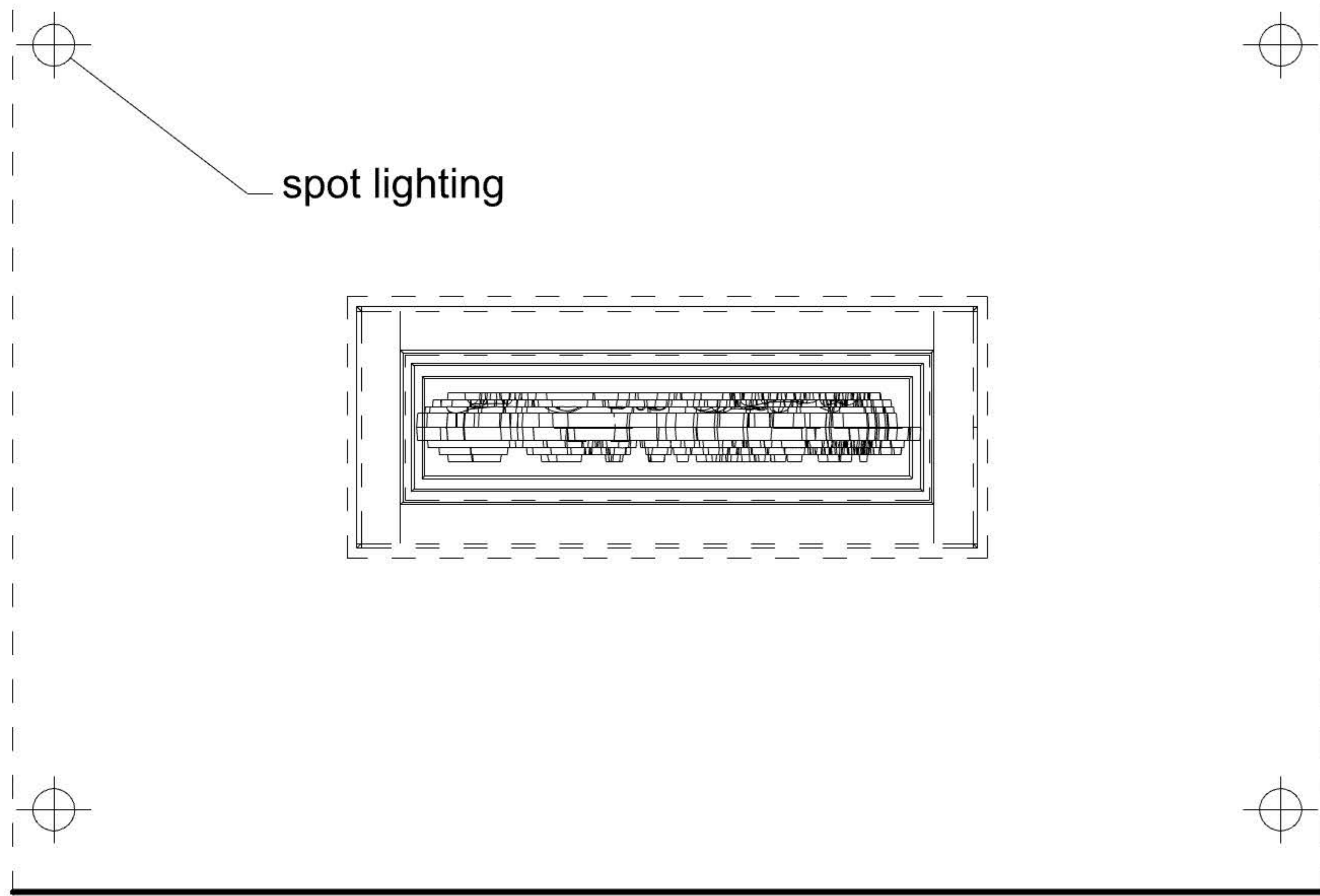

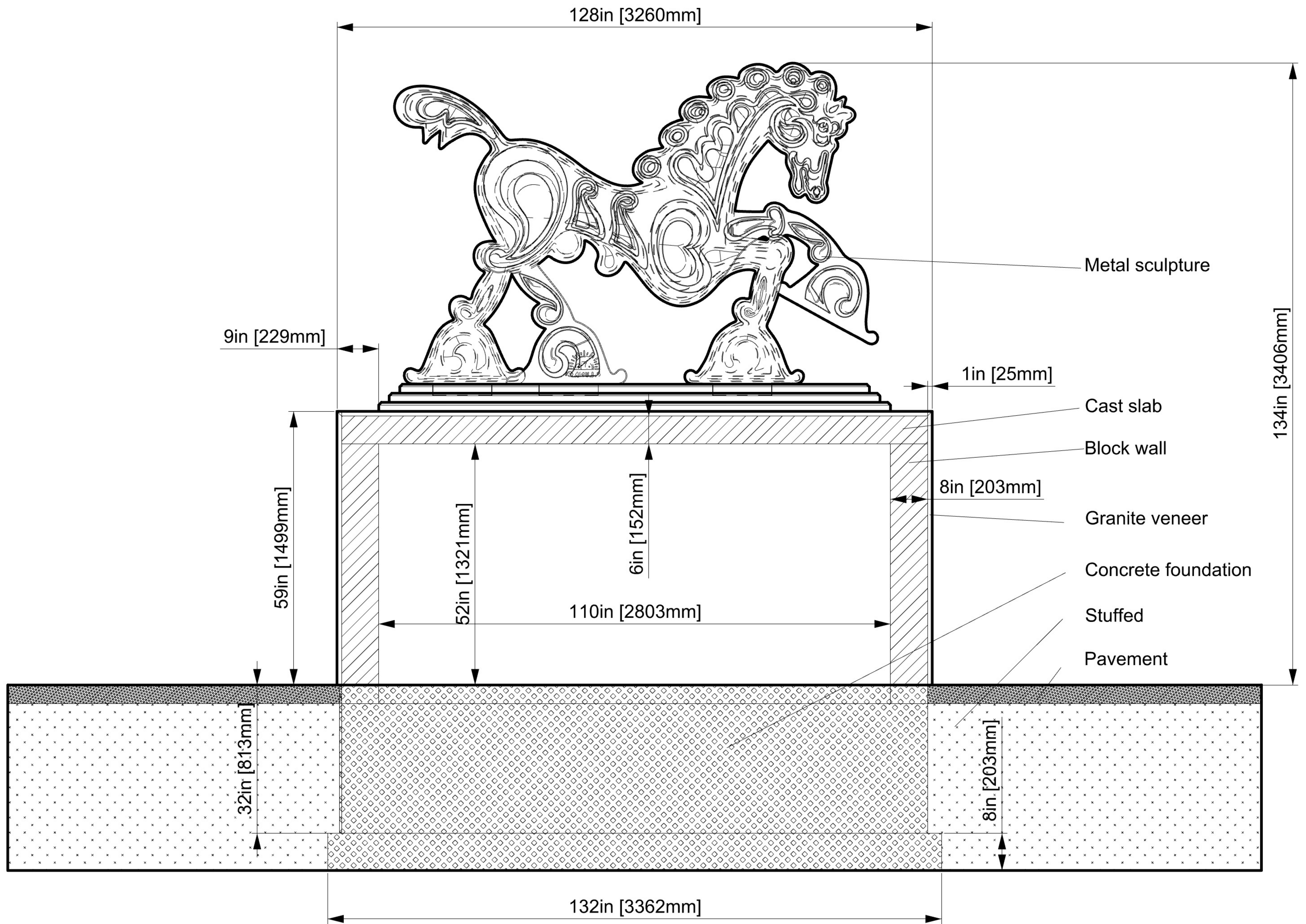

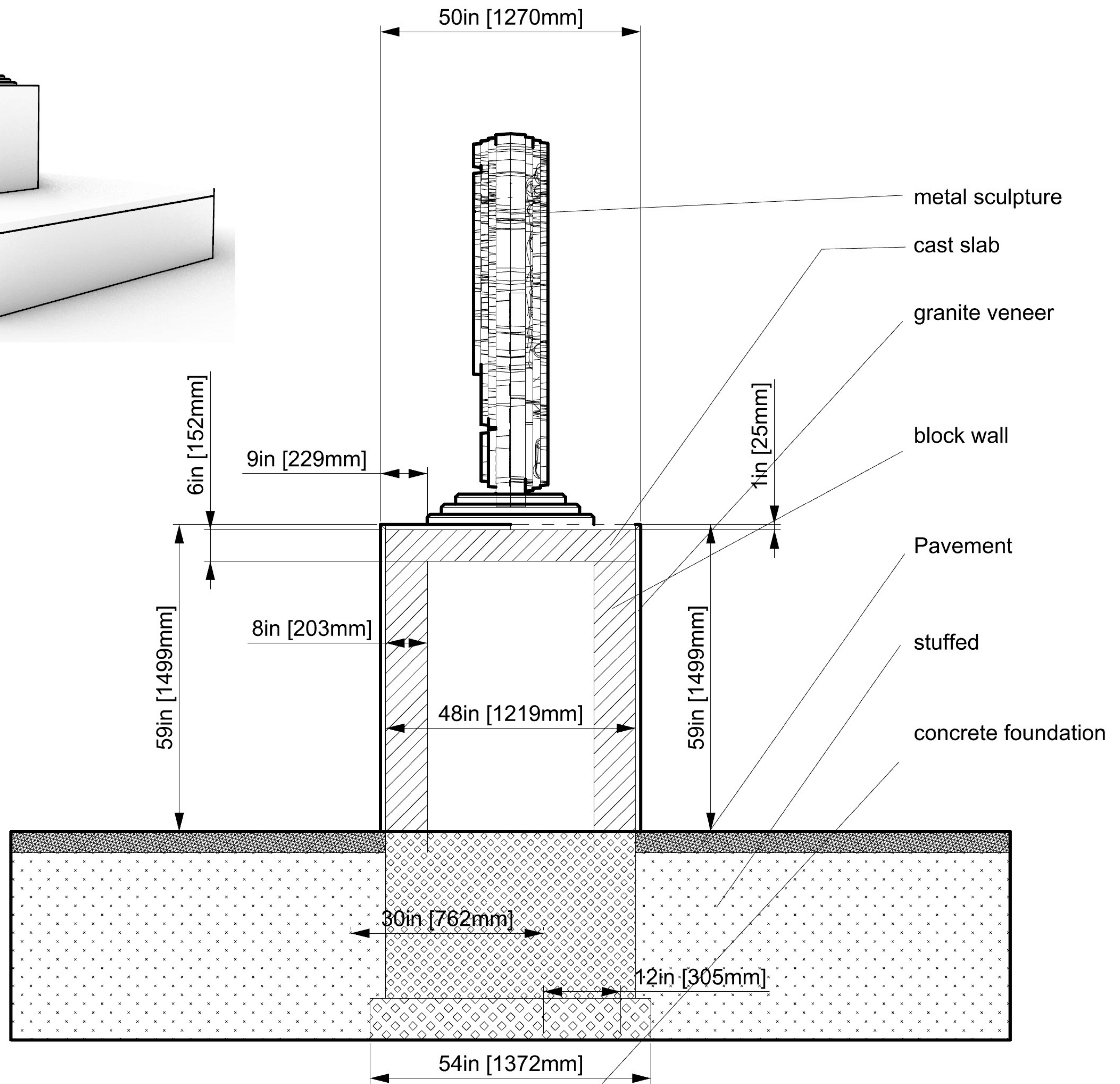
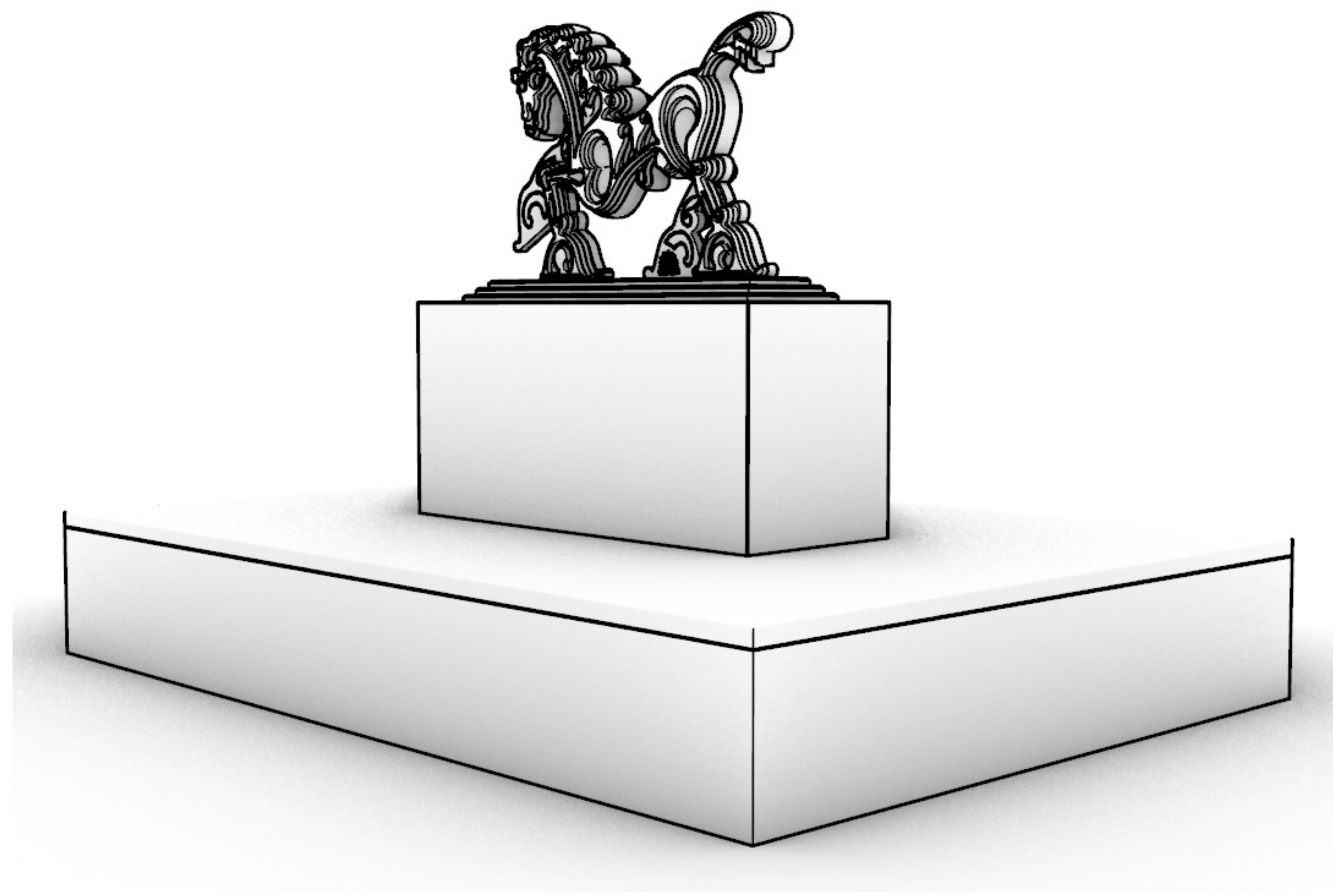



KOHLER

KOHLER

