



BOARD OF ADJUSTMENT MEETING NOTICE

August 25, 2022

A Public Hearing will be held before the Board of Adjustment on: Wednesday, September 14, 2022 at 6:00 P.M

This meeting will be held in the City Commission Chambers, City Hall, 1st Floor, 100 North Andrews Avenue, Fort Lauderdale, Florida 33301 to determine whether the following application should be granted:

CASE: PLN-BOA-22080005
OWNER: EHMKE, PAULA JEAN & RICHARD
AGENT: STEPHANIE TOOTHAKER, ESQ.
ADDRESS: 1400 SW 18th COURT, FORT LAUDERDALE, FL 33315
LEGAL DESCRIPTION: LOT 1 AND THE EAST 20 FEET OF LOT 2, BLOCK 18, REVISED PLAT OF YELLOWSTONE PARK 1 ACCORDING TO THE PLAT THEREOF AS RECORDED IN PLAT BOOK 23, PAGE 33, PUBLIC RECORDS OF BROWARD COUNTY, FLORIDA.
ZONING DISTRICT: RS-8 - RESIDENTIAL SINGLE FAMILY/LOW MEDIUM DENSITY
COMMISSION DISTRICT: 4
REQUESTING: Sec. 47-19.2. P.- Freestanding shade structures.

- A variance to request an existing freestanding shade structure with outdoor kitchen to be located in the front yard where the Code allows freestanding shade structures to be located in the rear yard.
- A variance to request an existing freestanding shade structure with outdoor kitchen to be 244 square feet whereas the Code allows a maximum of 200 square feet, variance request of 44 square feet.
- A variance to request an existing freestanding shade structure with outdoor kitchen to have a maximum height of 14.5 feet where the Code allows a maximum height of 12 feet measured from the ground to the top of the structure, variance request of 2.5 feet.
- A variance to request an existing freestanding shade structure with outdoor kitchen to have a full-height wall on one side where the Code allows all sides to be partially enclosed with 42-inch high built-in cabinetry.

Sec. 47-5.31. - Table of dimensional requirements for the RS-8 district. (Note A)

- A variance from the 25 feet minimum front yard requirements of Section 47-5.31 Table of Dimensional Requirements to allow an existing freestanding shade structure to remain at a front yard setback of 2 feet measured from the roof overhang, a total maximum variance request of 23 feet.

Note: To view more information about this item, please visit:
www.fortlauderdale.gov/government/BOA

If you have any questions, please feel free to contact me directly at 954-828-6342.

MOHAMMED MALIK
ZONING ADMINISTRATOR

Florida Statutes, Sec. 286.0105

NOTE: If any person decides to appeal any decision made with respect to any matter considered at this public meeting or hearing, he/she will need a record of the proceedings, and for such purpose, he/she may need to ensure that a verbatim record of the proceeding is made, which record includes the testimony and evidence upon which the appeal is to be based.



PLN-BOA-22080005

Path: J:\DSD\DRCLocationMaps_16_RM\ArcMap\BOA_2022_09-14\PLN-BOA-22080005.mxd

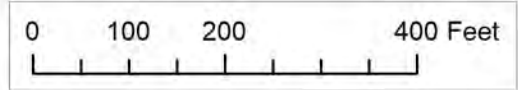

Graphic Scale



CITY OF FORT LAUDERDALE
PUBLIC NOTICE

BOARD OF ADJUSTMENT MEETING

DATE: SEPTEMBER 14, 2022

TIME: 6:00 PM

CASE: PLN-BOA-22080005

Requesting Sec. 47-19.2.P.- Freestanding shade structures.

- A variance to request an existing freestanding shade structure with outdoor kitchen to be located in the front yard where the Code allows freestanding shade structures to be located in the rear yard.
- A variance to request an existing freestanding shade structure with outdoor kitchen to be 244 square feet whereas the Code allows a maximum of 200 square feet, variance request of 44 square feet.
- A variance to request an existing freestanding shade structure with outdoor kitchen to have a maximum height of 14.5 feet where the Code allows a maximum height of 12 feet measured from the ground to the top of the structure, variance request of 2.5 feet.
- A variance to request an existing freestanding shade structure with outdoor kitchen to have a full-height wall on one side where the Code allows all sides to be partially enclosed with 42-inch high built-in cabinetry.

Requesting Sec. 47-5.31. - Table of dimensional requirements for the RS-8 district. (Note A)

- A variance from the 25 feet minimum front yard requirements of Section 47-5.31 Table of Dimensional Requirements to allow an existing freestanding shade structure to remain at a front yard setback of 2 feet measured from the roof overhang, a total maximum variance request of 23 feet.

LOCATION: CITY COMMISSION CHAMBERS
CITY HALL, 100 N ANDREWS AVENUE

INFORMATION: CONTACT (954) 828-6506
<http://www.fortlauderdale.gov>

This Notice is the property of the City of Fort Lauderdale. In accordance with City Code Section 16-29, It shall be unlawful for any person to injure, cut, break or destroy in any manner any building or other thing belonging to or under the control of the City. Persons marring or removing the Notice may be subject to fine and/or imprisonment.

In accordance with City Code Section 47-27.2A. H The sign shall remain on the property until final disposition of the application. This shall include any deferral, rehearing, appeal, request for review or hearing by another body. The sign information shall be changed as provided in subsection A.3.a



CITY OF FORT LAUDERDALE
PUBLIC NOTICE

BOARD OF ADJUSTMENT MEETING
 DATE: SEPTEMBER 14, 2022 TIME: 6:00 PM CASE: PLN-BOA-22080005

Requesting Sec. 47-19.2.P: Freestanding shade structures.
 • A variance to request an existing freestanding shade structure with outdoor kitchen to be located in the front yard where the Code allows freestanding shade structures to be located in the rear yard.
 • A variance to request an existing freestanding shade structure with outdoor kitchen to be 244 square feet whereas the Code allows a maximum of 200 square feet, variance request of 44 square feet.
 • A variance to request an existing freestanding shade structure with outdoor kitchen to have a maximum height of 14.5 feet where the Code allows a maximum height of 12 feet measured from the ground to the top of the structure, variance request of 2.5 feet.
 • A variance to request an existing freestanding shade structure with outdoor kitchen to have a full-height wall on one side where the Code allows all sides to be partially enclosed with 42-inch high built-in cabinetry.

Requesting Sec. 47-5.31: Table of dimensional requirements for the RS-8 district. (Note A)
 • A variance from the 25 feet minimum front yard requirements of Section 47-5.31 Table of Dimensional Requirements to allow an existing freestanding shade structure to remain at a front yard setback of 2 feet measured from the roof overhang, a total maximum variance request of 23 feet.

LOCATION: CITY COMMISSION CHAMBERS **INFORMATION: CONTACT (954) 828-6506**
CITY HALL, 100 N ANDREWS AVENUE **<http://www.fortlauderdale.gov>**

This notice is the property of the City of Fort Lauderdale. In accordance with City Code Section 16-29, it shall be unlawful for any person to print, cut, break or destroy in any manner any building or other thing belonging to or under the control of the City. Removal or tampering with this notice may be subject to the penalties of the ordinance.
 In accordance with City Code Section 47-22.1, if the sign shall be stolen, the property shall be disposed of the sign, the sign shall include any defacement, alteration, request for replacement, or other information as provided in subsection 47-22.1.

 CITY OF FORT LAUDERDALE
PUBLIC NOTICE

BOARD OF ADJUSTMENT MEETING
DATE: SEPTEMBER 14, 2022 TIME: 6:00 PM CASE: PLN-BOA-22080005

Requesting Sec. 47-19.2.P - Freestanding shade structures.
*A variance to request an existing freestanding shade structure with outdoor kitchen to be located in the front yard where the Code allows freestanding shade structures to be located in the rear yard.
*A variance to request an existing freestanding shade structure with outdoor kitchen to be 244 square feet whereas the Code allows a maximum of 200 square feet, variance request of 44 square feet.
*A variance to request an existing freestanding shade structure with outdoor kitchen to have a maximum height of 14.5 feet where the Code allows a maximum height of 12 feet measured from the ground to the top of the structure, variance request of 2.5 feet.
*A variance to request an existing freestanding shade structure with outdoor kitchen to have a full-height wall on one side where the Code allows all sides to be partially enclosed with 42-inch high built-in cabinetry.

Requesting Sec. 47-5.31 - Table of dimensional requirements for the RS-8 district. (Note A)
*A variance from the 25 feet minimum front yard requirements of Section 47-5.31 Table of Dimensional Requirements to allow an existing freestanding shade structure to remain at a front yard setback of 2 feet measured from the roof overhang, a total maximum variance request of 23 feet.

LOCATION: CITY COMMISSION CHAMBERS
CITY HALL, 100 N ANDREWS AVENUE **INFORMATION:** CONTACT (954) 828-6506
<http://www.fortlauderdale.gov>

This Notice is the property of the City of Fort Lauderdale. In accordance with City Code Section 16-29, it shall be unlawful for any person to remove, cut, break or destroy in any manner any building or other thing belonging to or under the control of the City. Persons meeting or removing the Notice may be subject to fine and/or imprisonment. In accordance with City Code Section 47-22.2A, if the sign shall remain on the property until final disposition of the application, the sign shall not be removed, altered, obscured, moved, or otherwise tampered with in any manner. The sign shall remain on the property until final disposition of the application. The sign shall not be removed, altered, obscured, moved, or otherwise tampered with in any manner.

BOA CASE # PLN-BOA-22080005

Sec. 47-19.2. P.- Freestanding shade structures.

Freestanding shade structures. Freestanding shade structures (such as a gazebo, a tiki hut, or a trellis) may be permitted when accessory to residential uses, in the required rear yard but no closer than five (5) feet from the rear property line except where a parcel is abutting a waterway, where they shall be no closer than ten (10) feet from the waterway as measured in accordance with Section 47-2.2.R. Freestanding shade structures shall be open on all sides and shall be no greater in height than twelve (12) feet measured from the ground to the top of the structure, and shall be limited in size to a maximum of two hundred (200) gross square feet in area for that portion of the structure protruding into the required yard area. No more than one (1) freestanding shade structure per plot shall be permitted in the required rear yard.

Sec. 47-5.31. - Table of dimensional requirements for the RS-8 district. (Note A)

<u>Requirements</u>	<u>RS-8</u>	<u>RS-8A</u>
<u>Maximum density</u>	<u>8.0 du/net ac.</u>	<u>8.0 du/net ac.</u>
<u>Minimum lot size</u>	<u>6,000 sq. ft.</u>	<u>6,000 sq. ft.</u>
<u>Maximum structure height</u>	<u>35 ft.</u>	<u>28 ft.</u>
<u>Maximum structure length</u>	<u>None</u>	<u>None</u>
<u>Minimum lot width</u>	<u>50 ft.</u> <u>*75 ft. when abutting a waterway on any side</u>	<u>50 ft.</u> <u>*75 ft. when abutting a waterway on any side</u>
<u>Minimum floor area</u>	<u>1,000 sq. ft.</u>	<u>1,000 sq. ft.</u>

<p><u>Minimum front yard</u></p>	<p><u>25 ft.</u></p> <p><u>Special minimum front yard setbacks:</u> <u>Coral Isles—15 ft.</u> <u>Nurmi Isles—20 ft.</u> <u>Pelican Isles—20 ft.</u></p>	<p><u>25 ft.</u></p> <p><u>Special minimum front yard setbacks:</u> <u>Coral Isles—15 ft.</u> <u>Nurmi Isles—20 ft.</u> <u>Pelican Isles—20 ft.</u></p>
<p><u>Minimum corner yard</u></p>	<p><u>25% of lot width but not greater than 25 ft.</u></p> <p><u>25 ft. when abutting a waterway</u></p>	<p><u>25% of lot width but not greater than 25 ft.</u></p> <p><u>25 ft. when abutting a waterway</u></p>
<p><u>Minimum side yard</u></p>	<p><u>5 ft. - up to 22 ft. in height</u></p> <p><u>Where a building exceeds 22 ft. in height that portion of the building above 22 ft. shall be set back an additional 1 foot per foot of additional height.</u></p> <p><u>25 ft. when abutting a waterway</u></p> <p><u>Special side yard setbacks 7.5 ft.:</u> <u>Coral Ridge Country Club Addition 4, P.B. 53 P. 29; Block G, Lots 1 thru 22; Block H, Lots 1 thru 10 and 16 thru 26; Block I; Block J.</u> <u>Gramercy Park, P.B. 57, P. 45, Block 1; and Block 2, Lots 1 thru 16.</u> <u>Coral Ridge Country Club Addition 3, P.B. 52 P. 14, Block A, Lots 1 thru 4; Block B, Lots 1 thru 4 and 7 thru 10; Block C, Lots 1 thru 4 and 7 thru 10; Block D, Lots 1 thru 8 and 11 thru 18; Block X, Lots 18 thru 20; Block J; Block K; Block L; Block M; Block N; Block O; Block P; Block Q; Block R; Block S; Block T.</u> <u>Golf Estates, P.B. 43, P. 26; Block 6; Block 7; Block 8; Block 9; Block 10; Block 11; Coral Ridge Country Club Subdivision P.B. 36 P. 30 Block F, Lots 1 thru 14; Block R, Lots 1 thru 8, 11 thru 18;</u> <u>Replat of Lots 11, 12, 13, 14 & 15 of Block H</u> <u>Coral Ridge Country Club Addition 4, P.B. 63 P. 31 Parcels A, B, C; Gramercy Park, PB 57 P. 45 Block 2, Lots 17 and 18; Coral Ridge Country Club Addition No. 2 P.B. 44 PG 21 Block F, Lots 2 thru</u></p>	<p><u>For a building with a height no greater than 12 ft.- 5 ft.</u></p> <p><u>For a building with a height greater than 12 ft. - 7.5 ft.</u></p> <p><u>That portion of a building exceeding 12 ft. in height shall be set back an additional 2 feet per 1 foot of additional height</u></p> <p><u>25 ft. when abutting a waterway</u></p> <p><u>Special side yard setbacks as provided in RS-8</u></p>

	19; Block E, Lots 1 thru 6 and 10 thru 16; Block C, Lots 2 thru 11; Block D, Lots 2 thru 4; Block B, Lot 2 and Lots 15 thru 25, and Bermuda-Riviera Subdivision of Galt Ocean Mile, P.B. 38 P. 46; Blocks A, C, D, E, F, G & H; Bermuda-Riviera Subdivision of Galt Ocean, First Addition, P.B. 40 P.12: Blocks J, K, L & M.				
<u>Minimum rear yard</u>	15 ft. 25 ft. when abutting a waterway <u>Special rear yard setbacks: 15 ft. abutting waterway in the following subdivisions:</u> Coral Ridge Isles Flamingo Pk.—Section "C" & "D" Lakes Estates Golf Estates Imperial Pt.—4th Sec. The Landings Rio Nuevo Isle—Block 1			25 ft. 25 ft. when abutting a waterway <u>Special rear yard setbacks as provided in RS-8</u>	
<u>Minimum distance between buildings</u>	None			None	
	<u>Lot Size</u>	<u>**Maximum Lot Coverage</u>	<u>**Maximum Floor Area Ratio</u>	<u>**Maximum Lot Coverage</u>	<u>**Maximum Floor Area Ratio</u>
	≤7,500 sf	50%	0.75	40%	0.55
<u>Lot coverage and FAR</u>	7,501—12,000 sf	45%	0.75	35%	0.55
	>12,000 sf	40%	0.60	30%	0.50

Note A: Dimensional requirements may be subject to additional regulations, see [Section 47-23](#), Specific Location Requirements, and [Section 47-25](#), Development Review Criteria.

* Allowances for modifications of lot widths may be permitted in accordance with the requirements of [Section 47-23.10](#), Specific Location Requirements.

** An increase in the maximum FAR or lot coverage may be permitted subject to the requirements of a site plan level III, see [Section 47-24.2](#).

*** All other regulations relating to district RS-8 shall apply to RS-8A.

(Ord. No. C-97-19, § 1(47-5.4), 6-18-97; Ord. No. C-99-26, § 1, 4-20-99; Ord. No. C-99-62, § 1, 9-21-99;
Ord. No. C-04-67, § 1, 1-4-05; Ord. No. C-08-05, § 3, 2-5-08)

Record, Permit, or Account #	Record Description	Application Name	Record Type	Balance	Planner Name	Street #	Dir	Street Name	Type	Opened Date	Status
PLN-BOA-22080005		Ehmke Residence Gazebo	Z- Board of Adjustment (BOA)	0		1400	SW		18 CT	8/5/2022	Open
PLN-BOA-22080002		Accessory Shade Structure Variance	Z- Board of Adjustment (BOA)	0		1400	SW		18 CT	8/2/2022	Complete
PLB-RES-22040192	after the fact permit, sink for summer kitchen	Ehmke Gazebo/summer kitchen legalization	Plumbing Residential Permit	0		1400	SW		18 CT	4/23/2022	Open
ELE-RES-22040211	after the fact permit, power receptacles and lighting for summer kitchen	Ehmke Gazebo/summer kitchen legalization	Electrical Residential Permit	0		1400	SW		18 CT	4/23/2022	Open
CE22030918	NOISE VIOLATION - LOUD MUSIC BEING PLAYED CAUSING A NUISANCE FOR NEIGHBORS.		Code Case	0	DARRINE	1400	SW		18 CT	3/21/2022	Withdrawn
CE22030269	Noise complaint		Code Case	0	DARRINE	1400	SW		18 CT	3/5/2022	Closed
CE21110417	QALERT # 846639 Neighbor says neighbors are having parties and loud noise during ball games. Would like an officer to come out around 2:30 P.M. Advised to call only when something is happening,.		Code Case	0	James Fetter	1400	SW		18 CT	11/15/2021	Closed
BLD-RNC-21100007	Work done without a permit. Legalizing tiki gazebo and summer kitchen.	Ehmke Gazebo/summer kitchen legalization	Residential New Construction Permit	0		1400	SW		18 CT	10/6/2021	Void
BLD-ACC-21100005	#ATF Legalizing Tiki gazebo and summer kitchen	Ehmke Gazebo/summer kitchen legalization	Accessory Structure Permit	329.4		1400	SW		18 CT	10/6/2021	Awaiting Client Reply
CE21080698	NOISE VIOLATION - EVERY DAY LOUD MUSIC IS PLAYED UNITL 3:30AM. FLPD ADVSIED COMPLAINANT TO CALL CODE!		Code Case	0	Manuel Garcia	1400	SW		18 CT	8/23/2021	Closed
CV21070004		681 CITATION	Violation-BLD Hearing	0	Alexander Albores	1400	SW		18 CT	7/9/2021	Closed
BE21070061		681 CITATION	Building Code Case	0	Alexander Albores	1400	SW		18 CT	7/9/2021	Closed
BE21060093	WORK WITHOUT PERMIT		Building Code Case	0	Jose Saragusti	1400	SW		18 CT	6/18/2021	Code Enforcement Board
BLD-FEN-21060019	NEW PVC FENCE 156 FT	NEW FENCE	Fence Permit	0		1400	SW		18 CT	6/7/2021	Complete
BLD-FEN-21040061	RETAINING WALL BP BLD-RPSF-20090013	RETAINING WALL BP BLD-RPSF-20090013	Fence Permit	0		1400	SW		18 CT	4/15/2021	Void
BE21010010	EXCAVATION/WORK PERFORMED WITHOUT PERMIT BEING ISSUED.		Building Code Case	0	Alexander Albores	1400	SW		18 CT	1/7/2021	Closed
BLD-ROOF-20090043	ROOF (BLD-ACC-20030003)		Re-Roof Permit	0		1400	SW		18 CT	9/8/2020	Void
BLD-RPSF-20090013	POOL	POOL	Residential Pool-Spa-Fountain Permit	0		1400	SW		18 CT	9/8/2020	Complete
ELE-RES-20090043	ELECTRICAL FOR POOL (BLD-RPSF-20090013)		Electrical Residential Permit	0		1400	SW		18 CT	9/8/2020	Complete
PLB-RES-20090051	PLUMBING FOR POOL (BLD-RPSF-20090013)		Plumbing Residential Permit	0		1400	SW		18 CT	9/8/2020	Complete

**1400 SW 18th Court
Fort Lauderdale, FL 33315**

PLN-BOA-22080005 - Variance Application

08/05/2022

Index

1. BOA Application
2. Variance Narrative
3. Agent Authorization Letter
4. Proof of Ownership
5. Current Site Photos
6. Mail Notice Documents
7. Survey
8. Site Plan
9. Architectural Plans
10. Exhibit 1: Section 47-19.2.P Interpretation





DEVELOPMENT SERVICES DEPARTMENT – ZONING & LANDSCAPING

BOARD OF ADJUSTMENT (BOA)

Rev: 5 Revision Date: 07/25/2022 | Print Date: 07/25/2022
I.D. Number: Z&L-BOA

BOARD OF ADJUSTMENT (BOA) INFORMATION AND APPLICATION

Cover :	Deadlines, Notes, Fees, and General Information
Page 1 :	Applicant Information Sheet
Page 2 :	Variance Request Criteria
Page 3 :	Required Documentation & Mail Notice Requirements
Page 4 :	Sign Notice Requirements & Affidavit
Page 5 :	Technical Specifications

BOARD OF ADJUSTMENT MEETING REQUEST: Prior to the submittal of the Board of Adjustment application, applicants are required to schedule a meeting request with Zoning and Landscaping Division staff to obtain feedback regarding the proposed variance, special exception, or other applications. The meeting includes general guidance on the submittal and process for the application type. A meeting can be requested by submitting an email request to the [Board of Adjustment](#).

APPLICATION DEADLINE: Submittals must be received by 5:00 PM each business day. Pursuant to Section 47-24.12, the Department will review all applications to determine completeness within five (5) business days. Applicants will be notified via e-mail, if application, survey, plans and other documentation do not meet the submittal requirements and if changes are required. The applicable deadline dates can be found on the City's website at the [Board of Adjustment](#) webpage.

ONLINE SUBMITTAL PROCESS: Submittals must be conducted through the City's online citizen access portal and payment of fees [LauderBuild](#). [LauderBuild](#) requires the creation of an online account to submit a complete application. To access submittal requirements and standards please visit the [LauderBuild Plan Room](#). Staff will provide guidance once an application has been submitted to the City.

DETERMINATION OF COMPLETENESS: Submittals are reviewed for completeness to ensure the application submittal contains all the required information including plans, survey, proof of ownership, narratives, and other pertinent documentation. The City will notify the applicant within five (5) business days from submittal with a determination of completeness. The notification will be sent via email and will indicate application completeness or incompleteness with required changes.

PAYMENT OF FEES: All applications for development permits are established by the City Commission, as set forth by resolution and amended from time to time. In addition to the application fee, any additional costs incurred by the City including review by a consultant on behalf of the City, or special advertising costs shall be paid by the applicant. Any additional costs, which are unknown at the time of application, but are later incurred by the City, shall be paid by the applicant prior to the issuance of a development permit. Applicants will receive invoices electronically indicating the applicable fee(s). Note, there are fees at various stages of review depending on application type. Fees are paid online.

PUBLIC SIGN NOTICE: Board of Adjustment (BOA) application, and certain applications are subject to public sign notice. Affidavits must be completed and submitted to the City stated compliance that such has been completed. The affidavit form can be found in this package on page 4 and on the City's website.

- Variance/Special Exception/Interpretation (Before): \$2,200
- Variance/Special Exception/Interpretation (After): \$2,800
- Variance/Special Exception/Interpretation (Before): \$650
- Residential (Homesteaded Only) Accessory Structures & Existing Non-Conforming Structures.
- Variance/Special Exception/Interpretation (After): \$850
- Residential (Homesteaded Only) Accessory Structures & Existing Non-Conforming Structures.
- Request For Continuance: \$900
- Request for Rehearing: \$300
- Rehearing Request before the board: \$1,150

Page 1: BOA - Applicant Information Sheet

INSTRUCTIONS: The following information is requested pursuant to the City's Unified Land Development Regulations (ULDR). While the information requested in this application is the minimum required to proceed please be aware additional information may be required to fully address the variance requested. The application must be filled out accurately and completely. Please print or type and answer all questions. Indicate N/A if does not apply.

NOTE: To be filled out by Department

Case Number	
Date of complete submittal	

NOTE: For purpose of identification, the **PROPERTY OWNER** is the **APPLICANT**

Property Owner's Name	EHMKE, PAULA JEAN & RICHARD
Property Owner's Signature	If a signed agent letter is provided, no signature is required on the application by the owner.
Address, City, State, Zip	1400 SW 18 CT, FORT LAUDERDALE, FL 33315
E-mail Address	
Phone Number	
Proof of Ownership	<input type="checkbox"/> Warranty Deed or <input checked="" type="checkbox"/> Tax Record

NOTE: If AGENT is to represent OWNER, notarized letter of consent is required

Applicant / Agent's Name	Stephanie Toothaker, Esq.
Applicant / Agent's Signature	<i>Stephanie Toothaker</i>
Address, City, State, Zip	501 SW 2nd Avenue, Suite A, Fort Lauderdale, FL 33301
E-mail Address	stephanie@toothaker.org, cc: roya@toothaker.org and estefania@toothaker.org
Phone Number	954.648.9376
Letter of Consent Submitted	<input checked="" type="checkbox"/>

Development / Project Name	Accessory Freestanding Shade Structure Variance
Existing / New	Existing: <input checked="" type="checkbox"/> New: <input type="checkbox"/>
Project Address	Address: 1400 SW 18 CT, FORT LAUDERDALE, FL 33315
Legal Description	See survey.
Tax ID Folio Numbers (For all parcels in development)	504216140470
Variance Request (Describe)	See narrative.
Applicable ULDR Sections	Sec. 47-19.2.P and Sec. 47-5.31

Current Land Use Designation	Low-Medium
Current Zoning Designation	RS-8
Current Use of Property	Single-Family Residence
Site Adjacent to Waterway	<input type="checkbox"/> Yes <input checked="" type="checkbox"/> No

Setbacks (indicate direction N, S, E, W)	Required	Proposed
Front	Corner Yard: 25% of lot width (17.5 feet)	2.8'
Side	5'	48.9'
Side	5'	9.3'
Rear	15'	106'

Page 2: Board of Adjustment (BOA) Criteria for Variance Request

Answer All questions on this page and attach narrative.

SPECIFIC REQUEST: State the specific request according to the ULDR or other provisions of the Code.

CRITERIA: Applicant must demonstrate a unique hardship attributable to the land by proving by a preponderance of the evidence for all of the following criteria. Please answer the following criteria completely. While some criteria may seem duplicative the response should be tailored specifically to each. Per section 47-24.12, A.4,

- a. Special conditions and circumstances affect the property at issue which prevent the reasonable use of such property; and
- b. Circumstances which cause the special conditions are peculiar to the property at issue, or to such a small number of properties that they clearly constitute marked exceptions to other properties in the same zoning district; and:
- c. Literal application of the provisions of the ULDR would deprive the applicant of a substantial property right that is enjoyed by other property owners in the same zoning district. (It shall be of no importance to this criterion that a denial of the variance sought might deny to the owner a more profitable use of the property, provided the provisions of the ULDR still allow a reasonable use of the property; and
- d. The unique hardship is not self-created by the applicant or his predecessors, nor is it the result of mere disregard for, or ignorance of, the provisions of the ULDR or antecedent zoning regulations; and
- e. The variance is the minimum variance that will make possible a reasonable use of the property and that the variance will be in harmony with the general purposes and intent of the ULDR and the use as varied will not be incompatible with adjoining properties or the surrounding neighborhood or otherwise detrimental to the public welfare.

AFFIDAVIT: I, Stephanie Toothaker, Esq. the Owner/Agent of said property ATTEST that I am aware of the following:

- 1. In order to be entitled to the relief requested in the application an affirmative vote of a majority plus one of the Board of Adjustment is required;
- 2. That in granting the relief requested, the Board of Adjustment is limited to the authority vested in the Board by the ULDR and that the Board may not grant the relief requested unless the applicant proves all the criteria specified in the ULDR have been met;
- 3. That the granting of relief by the Board does not exempt the applicant or owner of record from the responsibilities of obtaining all applicable permits or approvals as may be required by law for both new and existing structures;
- 4. That if the relief requested is granted by the Board, the applicant must secure a building permit to implement the relief requested within one hundred eighty (180) days of the entry of the final order of the Board, or within such lesser time as the Board may proscribe and that failure to procure the necessary permits within the time so proscribed shall render the variance or special exception null and void;
- 5. That if the Board denies the request for relief, then no additional application for the same or substantially the same relief may be entertained by the Board within two (2) years of the date of entry of the final order of denial.

Stephanie Toothaker
(Signature)

SWORN TO AND SUBSCRIBED before me in the County and State above aforesaid this 5th day of August, 2022



Estefania Mayorga
NOTARY PUBLIC
MY COMMISSION EXPIRES: 8.13.2023

Page 3: Required Documentation & Mail Notice Requirements

-Submit One (1) Completed (Digital) application submittal through "Lauderbuild" (<https://aca-prod.accela.com/>). Note: The plans and survey must be digitally signed and sealed when submitting through LauderBuild OR One (1) Original set signed and sealed with plans/survey at 24" x 36."

-Submit Fourteen (14) copy sets (stapled) of each item listed below and Survey/Plans at half-size scale 11"X17" & One (1) original application submittal.

- Completed application** (all pages must be filled, completed, signed and notarized, where applicable).
- Mail notification documents** (mail notification instructions at bottom of page) .
- Proof of ownership** (Broward County Property Records, warranty deed, and/or Sunbiz), including corporation documents if applicable.
- Property owners original notarized signature** and/or notarized agent letter signed by the property owner (if applicable).
- Color photographs** of the entire property and all surrounding properties, dated and labeled and identified as to orientation.
- Narrative** describing specific request and outlining ULDR sections that are applicable. Narratives must be on letterhead, dated, and with author indicated.
- Cover sheet** on plan set to state project name and table of contents.
- Current survey(s)** of property, signed and sealed, showing existing conditions; survey must be As-Built with Right-of-Way and Easement Vacations Excluded. The survey should consist of the proposed project site alone. Do not include adjacent properties or portions of lands not included in the proposed project unless specifically requested by the City.

- Site Plan** (a survey may be substituted if the requested variance is clearly indicated)
- Landscape Plan** (if applicable)
- Elevations** (if applicable)
- Additional Plan details as needed**

Note: All copy sets must be clear and legible.

Note: Plans must be folded to 8 ½" x 11". All non-plan documents should be 8 ½" x 11".

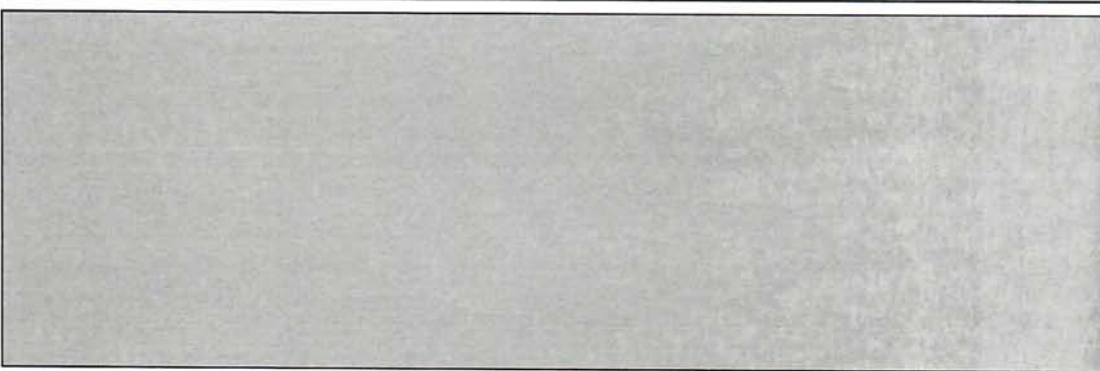

MAIL NOTIFICATION: Pursuant to Section 47-27.2 Types of Public Notice and 47-27.9 Variance, Special Exception, Temporary Non-Conforming Use, Interpretation requires the following notice:

- **MAIL NOTICE:** Mail notice shall be given to owners of land within three hundred (300) feet of the subject site ten (10) days prior to the date set for the public hearing.
 - **TAX MAP:** Applicant shall provide a tax map from the Broward County Property Appraiser of all property within a three hundred (300) foot radius, with each property clearly shown and delineated. Each property within the notice area must be numbered (by Folio ID) on the map to cross-reference with property owners notice list.
 - **PROPERTY OWNERS NOTICE LIST:** Applicant shall provide a property owner notice list with the names, property control numbers (Folio ID) and complete addresses for all property owners within the required three hundred (300) foot radius. The list shall also include all homeowners' associations, condominium associations, municipalities and counties noticed, as indicated on the tax roll.
 - **ENVELOPES:** The applicant shall provide business size (#10) envelopes with first class postage attached (stamps only, metered mail will not be accepted). Envelopes must be addressed to all property owners within the required three hundred (300) foot radius, and mailing addresses must be typed or labeled; no handwritten addresses will be accepted. The return address shall be listed on all envelopes as follows:

**City of Fort Lauderdale
Zoning & Landscaping Division -BOA
700 NW 19th Avenue, Fort Lauderdale, FL 33311**

- **DISTRIBUTION:** The City of Fort Lauderdale, Zoning & Landscaping Division will mail all notices prior to the public hearing meeting date, as outlined in Section 47-27.
- **To order a tax map and notice list, please email Heather Hanson at hhanson@bcpa.net or call 954-357-6855. You may also contact Kenny Gibbs, kgibbs@bcpa.net or call 954-357-5503.**



Site Address	1400 SW 18 COURT, FORT LAUDERDALE FL 33315	ID #	5042 16 14 0470
Property Owner	EHMKE, PAULA JEAN & RICHARD	Millage	0312
Mailing Address	1400 SW 18 CT FORT LAUDERDALE FL 33315	Use	01-01
Abbr Legal Description	REV PLAT YELLOWSTONE PARK 23-33 B LOT 1,2 E 20 BLK 18		

The just values displayed below were set in compliance with [Sec. 193.011](#), Fla. Stat., and include a reduction for costs of sale and other adjustments required by [Sec. 193.011\(8\)](#).

* 2022 values are considered "working values" and are subject to change.

Year	Land	Building / Improvement	Just / Market Value	Assessed / SOH Value	Tax
2022*	\$129,980	\$1,045,270	\$1,175,250	\$813,050	
2021	\$129,980	\$747,750	\$877,730	\$770,210	\$14,089.13
2020	\$129,980	\$629,600	\$759,580	\$759,580	\$13,823.57

2022* Exemptions and Taxable Values by Taxing Authority				
	County	School Board	Municipal	Independent
Just Value	\$1,175,250	\$1,175,250	\$1,175,250	\$1,175,250
Portability	0	0	0	0
Assessed/SOH 20	\$813,050	\$813,050	\$813,050	\$813,050
Homestead 100%	\$25,000	\$25,000	\$25,000	\$25,000
Add. Homestead	\$25,000	0	\$25,000	\$25,000
Wid/Vet/Dis	0	0	0	0
Senior	0	0	0	0
Exempt Type	0	0	0	0
Taxable	\$763,050	\$788,050	\$763,050	\$763,050

Sales History			
Date	Type	Price	Book/Page or CIN
12/19/2019	WD-Q	\$841,000	116252728
12/20/2018	QCD-T	\$328,800	115521527
5/7/2018	QCD-T	\$333,500	115067978
7/26/2005	WD	\$365,000	40185 / 726
12/1/1986	QCD	\$32,500	14169 / 195

Land Calculations		
Price	Factor	Type
\$15.00	8,665	SF
Adj. Bldg. S.F. (Card, Sketch)		4872
Units/Beds/Baths		1/4/4
Eff./Act. Year Built: 2009/2008		

Special Assessments								
Fire	Garb	Light	Drain	Impr	Safe	Storm	Clean	Misc
03						F1		
R								
1						1		

**EHMKE FAMILY
1400 SW 18TH COURT
FORT LAUDERDALE, FL 33315**

May 24, 2022

City of Fort Lauderdale
Office of the City Clerk
100 N. Andrews Avenue, 7th Floor
Fort Lauderdale, FL 33301

Broward County Board of County Commissioners
115 S. Andrews Avenue, #409
Fort Lauderdale, FL 33301

**Re: Section 2-262, City of Fort Lauderdale Code of Ordinances and
Broward County Ordinance No. 2009-34 Authorization Letter**

To Whom it May Concern:

Please accept this letter of authorization permitting Stephanie J. Toothaker, Esq., Estefania Mayorga, and Roya Edwards of Stephanie J. Toothaker, Esq., P.A. d/b/a TOOTHAKER.org to represent the interests of **EHMKE, PAULA JEAN & RICHARD** in connection with permitting in the City of Fort Lauderdale and Broward County regarding the properties located at **1400 SW 18 COURT, FORT LAUDERDALE, 33315**.

Sincerely,



Name: Paula Ehmke
Title: Authorized Signatory



Name: Richard Ehmke
Title: Authorized Signatory

STATE OF FL
COUNTY OF Broward

The foregoing instrument was acknowledged before me by means of physical presence or online notarization this 26 day of May, 2022, by [INSERT], as the _____ of [INSERT].

(Notary Seal)

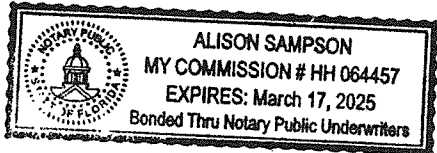

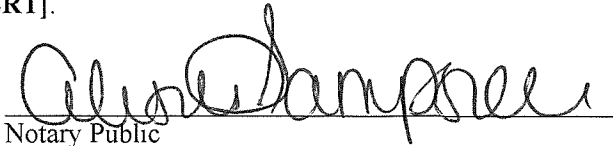
Notary Public

Alison Sampson
Name typed, printed or stamped

Personally Known OR _____ Produced Identification
Type of Identification Produced _____



0 37.5 75 150 225 300 Feet

MARTY KIAR
BROWARD COUNTY PROPERTY APPRAISER



1400 SW 18 CT
DATE OF PRINT: 08/02/2022

FOLIO_NUMB	NAME_LINE_	NAME_LINE1	ADDRESS_LI	CITY	STATE	ZIP	ADDRESS_1	LEGAL_LINE	LEGAL_LI_1	LEGAL_LI_2	
504216121090	GEORGE,MATTHEW R & PATRICIA O		1801 SW 13 AVE	FORT LAUDERDALE	FL	33315	FORT LAUDERDALE	FL33315	YELLOWSTONE PARK AMEN PLAT	15-3 B	PT BLK 15 F/P/A LOTS 1,2 BLK 15
504216121100	GRIFFIS,HELEN		1306 SW 18 ST	FORT LAUDERDALE	FL	33315	FORT LAUDERDALE	FL33315	YELLOWSTONE PARK AMEN PLAT	15-3 B	PT BLK 15 F/P/A LOT 3 BLK 15
504216121110	SIEGEL,PATRICIA LOUISE		1316 SW 18 ST	FORT LAUDERDALE	FL	33315	FORT LAUDERDALE	FL33315	YELLOWSTONE PARK AMEN PLAT	15-3 B	PT BLK 15 F/P/A LOTS 4,5 BLK 15
504216121120	HIEBERT,EVA H/E	HIEBERT,JARRETT	1820 SW 14 AVE	FORT LAUDERDALE	FL	33315	FORT LAUDERDALE	FL33315	YELLOWSTONE PARK AMEN PLAT	15-3 B	PT BLK 15 F/P/A LOT 6,7 W 10
504216121130	CHARLES,CLAIRMONTE		1323 SE 17 ST #133	FORT LAUDERDALE	FL	33316	FORT LAUDERDALE	FL33316	YELLOWSTONE PARK AMEN PLAT	15-3 B	PT BLK 15 F/P/A LOT 7 E 40,8
504216121140	BEASLEY,KATHLEEN C		1307 SW 18 CT	FORT LAUDERDALE	FL	33315	FORT LAUDERDALE	FL33315	YELLOWSTONE PARK AMEN PLAT	15-3 B	PT BLK 15 F/P/A LOT 8 E 30,9
504216121150	CARBONELL,GUSTAVO J & VERONICA		1301 SW 18 CT	FORT LAUDERDALE	FL	33315	FORT LAUDERDALE	FL33315	YELLOWSTONE PARK AMEN PLAT	15-3 B	PT BLK 15 F/P/A LOT 9 E 20,10
504216121160	WILLIAMS,MICHAEL EDWARD & TAMERA		1300 SW 18 CT	FORT LAUDERDALE	FL	33315	FORT LAUDERDALE	FL33315	YELLOWSTONE PARK AMEN PLAT	15-3 B	PT OF BLK 19 F/P/A LOT 1,2 E 15
504216121170	CARBONELL,ERIC		1306 SW 18 CT	FORT LAUDERDALE	FL	33315	FORT LAUDERDALE	FL33315	YELLOWSTONE PARK AMEN PLAT	15-3 B	PT BLK 19 F/P/A LOT 2 W 35,3
504216121180	SEREMETA,VICTORIA & TIMOTHY E		1312 SW 18 CT	FORT LAUDERDALE	FL	33315	FORT LAUDERDALE	FL33315	YELLOWSTONE PARK AMEN PLAT	15-3 B	PT BLK 19 F/P/A LOT 3 W 25,4
504216121190	DUTTON,WHITNEY & PAIGE O		1320 SW 18 CT	FORT LAUDERDALE	FL	33315	FORT LAUDERDALE	FL33315	YELLOWSTONE PARK AMEN PLAT	15-3 B	PT BLK 19 F/P/A LOT 4 W 15,5
504216121200	STIFFT,BREN S		1321 SW 19 ST	FORT LAUDERDALE	FL	33315	FORT LAUDERDALE	FL33315	YELLOWSTONE PARK AMEN PLAT	15-3 B	PT BLK 19 F/P/A LOTS 6,7 W 15
504216121210	KERLIN,CHRISTOPHER M		1313 SW 19 ST	FORT LAUDERDALE	FL	33315	FORT LAUDERDALE	FL33315	YELLOWSTONE PARK AMEN PLAT	15-3 B	PT BLK 19 F/P/A LOT 7 E 35,8
504216121220	NEWTON,DIANA		1307 SW 19 ST	FORT LAUDERDALE	FL	33315	FORT LAUDERDALE	FL33315	YELLOWSTONE PARK AMEN PLAT	15-3 B	PT BLK 19 F/P/A LOT 8 E 25,
504216121230	PHILLIPS,JOHN M & KATHLEEN C		1835 SW 13 AVE	FORT LAUDERDALE	FL	33315	FORT LAUDERDALE	FL33315	YELLOWSTONE PARK AMEN PLAT	15-3 B	PT BLK 19 F/P/A LOT 9 E 15,10
504216121960	DUTTON,WHITNEY	DUTTON,PAIGE	1320 SW 18 CT	FORT LAUDERDALE	FL	33315	FORT LAUDERDALE	FL33315	YELLOWSTONE PARK AMEN PLAT	15-3 B	THAT POR OF BLK 26 F/P/A LOT 2 &
504216121970	ALBRIGHT,MEAGAN A	CALVO,PABLO J	1312 SW 19 ST	FORT LAUDERDALE	FL	33315	FORT LAUDERDALE	FL33315	YELLOWSTONE PARK AMEN PLAT	15-3 B	PT BLK 26 FPA LOT 3 W1/2,4
504216121980	LOOS,MATTHEW S		1316 SW 19 ST	FORT LAUDERDALE	FL	33315	FORT LAUDERDALE	FL33315	YELLOWSTONE PARK AMEN PLAT	15-3 B	PT BLK 26 F/P/A LOT 4 W 15,5
504216140350	P&M ACCESS GROUP LLC		725 NE 26 AVE	FORT LAUDERDALE	FL	33304	FORT LAUDERDALE	FL33304	REV PLAT YELLOWSTONE PARK	23-33 B	LOT 1,2 E 20 BLK 16
504216140360	MOSS,FRED & RACHEL		1404 SW 18 CT	FORT LAUDERDALE	FL	33315	FORT LAUDERDALE	FL33315	REV PLAT YELLOWSTONE PARK	23-33 B	LOT 2 W 30,3 E 30 BLK 16
504216140370	YGLESIAS,ABDUL J		1408 SW 18 ST	FORT LAUDERDALE	FL	33315	FORT LAUDERDALE	FL33315	REV PLAT YELLOWSTONE PARK	23-33 B	LOT 3 W 20,4 E 40 BLK 16
504216140380	JOHNS,MARJORIE H		1412 SW 18 ST	FORT LAUDERDALE	FL	33315	FORT LAUDERDALE	FL33315	REV PLAT YELLOWSTONE PARK	23-33 B	LOT 4 W 10,5 BLK 16
504216140390	DRISCOLL,MICHAEL J		1416 SW 18 ST	FORT LAUDERDALE	FL	33315	FORT LAUDERDALE	FL33315	REV PLAT YELLOWSTONE PARK	23-33 B	LOT 6 E 60 BLK 16
504216140400	BAY RIDGE 1935 LLC		1471 SW 21 CT	FORT LAUDERDALE	FL	33315	FORT LAUDERDALE	FL33315	REV PLAT YELLOWSTONE PARK	23-33 B	LOT 6 W 10,7 BLK 16
504216140410	JOHNSON,MICHAEL		805 HAMPTON CT	WESTON	FL	33326	WESTON	FL33326	REV PLAT YELLOWSTONE PARK	23-33 B	LOT 8,9 W 10 BLK 16
504216140420	FRANKLIN,GARTHER LEVON JR		1417 SW 18 CT	FORT LAUDERDALE	FL	33315	FORT LAUDERDALE	FL33315	REV PLAT YELLOWSTONE PARK	23-33 B	LOT 9 LESS W 10 BLK 16
504216140430	LORD,SHARN H/E	LORD,COLIN D F	1413 SW 18 CT	FORT LAUDERDALE	FL	33315	FORT LAUDERDALE	FL33315	REV PLAT YELLOWSTONE PARK	23-33 B	LOT 10,11 W 10 BLK 16
504216140440	PRESTON,CHASE	FLEISHER,CAROLINE	1409 SW 18 CT	FORT LAUDERDALE	FL	33315	FORT LAUDERDALE	FL33315	REV PLAT YELLOWSTONE PARK	23-33 B	LOT 11 E 40,12 W 20 BLK 16
504216140450	CAMERON,THOMAS J & LINDA A		1405 SW 18 CT	FORT LAUDERDALE	FL	33315	FORT LAUDERDALE	FL33315	REV PLAT YELLOWSTONE PARK	23-33 B	LOT 12 E 30,13 W 30 BLK 16
504216140460	BOYER,DAVID W		1821 SW 14 AVE	FORT LAUDERDALE	FL	33315	FORT LAUDERDALE	FL33315	REV PLAT YELLOWSTONE PARK	23-33 B	LOT 13 E 20,14 BLK 16
504216140470	EHMKE,PAULA JEAN & RICHARD		1400 SW 18 CT	FORT LAUDERDALE	FL	33315	FORT LAUDERDALE	FL33315	REV PLAT YELLOWSTONE PARK	23-33 B	LOT 1,2 E 20 BLK 18
504216140480	FERNANDEZ FONT,DEREK		1404 SW 18 CT	FORT LAUDERDALE	FL	33315	FORT LAUDERDALE	FL33315	REV PLAT YELLOWSTONE PARK	23-33 B	LOT 2 W 30,3 E 30 BLK 18
504216140490	HILL,J S & TERRY P		1408 SW 18 CT	FORT LAUDERDALE	FL	33315	FORT LAUDERDALE	FL33315	REV PLAT YELLOWSTONE PARK	23-33 B	LOT 3 W 20,4 E 40 BLK 18
504216140500	WANTLAND,HEATHER		1412 SW 18 CT	FORT LAUDERDALE	FL	33315	FORT LAUDERDALE	FL33315	REV PLAT YELLOWSTONE PARK	23-33 B	LOT 4 W 10,5 BLK 18
504216140510	MURPHY,KEVIN L & ASHLEA O		1416 SW 18 CT	FORT LAUDERDALE	FL	33315	FORT LAUDERDALE	FL33315	REV PLAT YELLOWSTONE PARK	23-33 B	LOT 6 E 60 BLK 18
504216140520	GRINER,DAVID & BROOKE		1824 COCONUT DR	FORT LAUDERDALE	FL	33315	FORT LAUDERDALE	FL33315	REV PLAT YELLOWSTONE PARK	23-33 B	LOT 6 W 10,7 BLK 18
504216140530	STAMPER,STEPHEN SCOTT		1425 SW 19 ST	FORT LAUDERDALE	FL	33315	FORT LAUDERDALE	FL33315	REV PLAT YELLOWSTONE PARK	23-33 B	LOT 8,9 W 10 BLK 18
504216140540	SHARPE,ORLANDO	SHARPE,SANDRA	1417 SW 19 ST	FORT LAUDERDALE	FL	33315	FORT LAUDERDALE	FL33315	REV PLAT YELLOWSTONE PARK	23-33 B	LOT 9 E 60 BLK 18
504216140550	DONALDSON,STEWART G		PO BOX 2530	FORT LAUDERDALE	FL	33303	FORT LAUDERDALE	FL33303	REV PLAT YELLOWSTONE PARK	23-33 B	LOT 10,11 W 10 BLK 18
504216140560	LES AUX,MAXINE	LES AUX,RENEE	1409 SW 19 STREET	FORT LAUDERDALE	FL	33315	FORT LAUDERDALE	FL33315	REV PLAT YELLOWSTONE PARK	23-33 B	LOT 11 E 40,12 W 20 BLK 18
504216140570	BOBKAT LLC		2628 ARBOR DR	FORT LAUDERDALE	FL	33312	FORT LAUDERDALE	FL33312	REV PLAT YELLOWSTONE PARK	23-33 B	LOT 12 E 30,13 W 30 BLK 18
504216140580	PALMS & PETALS LLC		1188 BROOKHAVEN PARK	ATLANTA	GA	30319	ATLANTA	GA30319	REV PLAT YELLOWSTONE PARK	23-33 B	LOT 13 E 20,14 BLK 18
504216140590	SALVER,SAMANTHA		1400 SW 19 ST	FORT LAUDERDALE	FL	33315	FORT LAUDERDALE	FL33315	REV PLAT YELLOWSTONE PARK	23-33 B	LOT 1,2 BLK 27
504216140600	COURSEN,JOHN D & YANET D		1408 SW 19 ST	FORT LAUDERDALE	FL	33315	FORT LAUDERDALE	FL33315	REV PLAT YELLOWSTONE PARK	23-33 B	LOT 3,4 E 10 BLK 27
504216140610	BATTLE,KYRA	KYRA BATTLE TR	1412 SW 19 ST	FORT LAUDERDALE	FL	33315	FORT LAUDERDALE	FL33315	REV PLAT YELLOWSTONE PARK	23-33 B	LOT 4 W 40,5 E 14 BLK 27
504216140620	PEREZ,GUSTAVO A ZINGG		1416 SW 19 ST	FORT LAUDERDALE	FL	33315	FORT LAUDERDALE	FL33315	REV PLAT YELLOWSTONE PARK	23-33 B	LOT 5 W 36,6 E 24 BLK 27
504216140630	PUTNAM,CYNTHIA		1420 SW 19 ST	FORT LAUDERDALE	FL	33315	FORT LAUDERDALE	FL33315	REV PLAT YELLOWSTONE PARK	23-33 B	LOT 6 W 46,7 E 14 BLK 27
504216140700	BALANI,ENINA		1405 SW 20 ST	FORT LAUDERDALE	FL	33315	FORT LAUDERDALE	FL33315	REV PLAT YELLOWSTONE PARK	23-33 B	LOT 12 E 10,13 W 40 BLK 27
504216140710	MARIA,MIGUEL		3350 SW 148 AVE STE 110	MIRAMAR	FL	33027	MIRAMAR	FL33027	REV PLAT YELLOWSTONE PARK	23-33 B	LOT 13 E 10,14 BLK 27

August 5, 2022
Updated August 17, 2022

VIA LAUDERBUILD
BOARD OF ADJUSTMENT
C/O MOHAMMED MALIK, ZONING ADMINISTRATOR/LIAISON
CITY OF FORT LAUDERDALE
100 NORTH ANDREWS AVENUE
FORT LAUDERDALE, FL 33311

RE: After-the-Fact Variance Request for 1400 SW 18th Court, Fort Lauderdale, Florida 33301

Dear Honorable Members of the Board of Adjustment:

This firm represents Paula and Richard Ehmke (the “Applicant”), owners of the real property located at 1400 SW 18th Court, Folio No. 504216140470 (the “Property”). The Property has an underlying land use designation of Low-Medium Residential (“Low-Medium”) and is zoned Residential Single Family/Low Medium Density District (“RS-8”). On behalf of the Applicant, we are respectfully requesting approval of an after-the-fact variance from the Unified Land Development Regulations (“ULDR”) Sections 47-19.2.P and 47-5.31 which establishes the dimensional requirements for freestanding shade structures and structures built in the RS-8 zoning district. The requested variance is for a freestanding shade structure with an outdoor kitchen (“Gazebo”) that is accessory to the single-family home.

1. PROJECT DESCRIPTION

The Property is 8,665 square feet and located on a corner lot in the River Oaks community, fronting SW 18th Court to the north and SW 14th Avenue to the east. The current structures on the Property include the single-family residence built in 2008 and an accessory pool, spa, and Gazebo.

The primary residence occupies a majority of the lot coverage, leaving minimal area in the rear yard to locate the accessory pool, spa, and Gazebo. These amenities are therefore located in the front yard due to the limited rear yard area. Please see **Sheet SP-1** and the **Site Photos** provided in this application package for a clear depiction of where the Gazebo is located in relation to the principal building and setbacks, abutting properties, and right-of-way.

The Applicant submitted an after-the-fact permit (Permit No. BLD-ACC-21100005) for the Gazebo and is required to obtain an after-the fact variance for certain aspects of the Gazebo for permit issuance. The Gazebo is 14.5 feet high measured from the ground to the top roof ridge and is 244 gross square feet under roof area. The west and south elevations are partially enclosed with 34-inch high built-in cabinetry with countertops and kitchen appliances. The north elevation also features 34-inch high built-in cabinetry with a full-height wall. The east elevation is fully open with clear ingress and egress.

Stephanie J. Toothaker, Esq.
land use development political strategy procurement

2. REQUESTED VARIANCE

ULDR Section 47-19.2.P states that:

“...freestanding shade structures may be permitted when accessory to residential uses in the required rear yard but no closer than five (5) feet from the rear property line except where a parcel is abutting a waterway, where they shall be no closer than ten (10) feet from the waterway as measured in accordance with Section 47-2.2.R. **Freestanding shade structures shall be open on all sides and shall be no greater in height than twelve (12) feet measured from the ground to the top of the structure, and shall be limited in size to a maximum of two hundred (200) gross square feet in area for that portion of the structure protruding into the required yard area. No more than one (1) freestanding shade structure per plot shall be permitted in the required rear yard.**”

Additionally, pursuant to the City Zoning Administrator’s revised interpretation, attached hereto as **Exhibit “1”**, outdoor kitchens within shade structures are permitted to encroach into the rear setback a distance of 5-feet from the property line or 10-feet abutting a waterway. Additionally, outdoor kitchens (including outdoor sinks, refrigeration, cooktops and associated electrical, plumbing, and gas lines) can be included in the shade structure encroachment on all sides up to 42-inches tall if clear ingress or egress is maintained at 36-inches wide.

ULDR Section 47-5.31 states the minimum front yard requirement for the RS-8 zoning district is 25 feet.

As such, we are respectfully requesting a variance from the following:

ULDR Section 47-19.2.P. Free Standing Shade Structures:

1. A variance to request an existing freestanding shade structure with outdoor kitchen to be located in the front yard where the Code allows freestanding shade structures to be located in the rear yard;
2. A variance to request an existing freestanding shade structure with outdoor kitchen to be 244 square feet whereas the Code allows a maximum of 200 square feet, variance request of 44 square feet;
3. A variance to request an existing freestanding shade structure with outdoor kitchen to have a maximum height of 14.5 feet where the Code allows a maximum height of 12 feet measured from the ground to the top of the structure, variance request of 2.5 feet;
4. A variance to request an existing freestanding shade structure with outdoor kitchen to have a full-height wall on one side where the Code allows all sides to be partially enclosed with 42-inch high built in cabinetry; and

ULDR Section 47-5.31 – Table of Dimensional Requirements for the RS-8 District:

5. A variance from the 25 feet minimum front yard requirements of Section 47-5.31 Table of Dimensional Requirements to allow an existing freestanding shade structure to remain at a front yard setback of 2 feet measured from the roof overhang, a total maximum variance request of 23 feet.

3. CRITERIA FOR APPROVAL OF BOA VARIANCE REQUEST

- a. *That special conditions and circumstances affect the property at issue which prevent the reasonable use of such property; and*

RESPONSE: The Applicant purchased the Property with the existing primary residence. The orientation of the primary residence on the Property is a special condition preventing the construction of the Gazebo in the rear yard. The Gazebo was built in the front yard and encroaches into the front yard setback due to these special circumstances. Additionally, the purpose of the freestanding shade structure is to act as an outdoor kitchen which is permitted according to the City's zoning interpretation of ULDR Section 47-19.2.P.

- b. *That the circumstances which cause the special conditions are peculiar to the property at issue, or to such a small number of properties that they clearly constitute marked exceptions to other properties in the same zoning district; and*

RESPONSE: The accessory structure is not open to the public, is located on a private residence, and will only affect the property at issue. It is concealed by foliage and landscaping and is protected from the public by fencing around the perimeter of the Property. The accessory structure and the existing conditions on the Property are unique and can be considered a marked exception when compared to other properties within the zoning district.

- c. *That the literal application of the provisions of the ULDR would deprive the applicant of a substantial property right that is enjoyed by other property owners in the same zoning district. It shall be of no importance to this criterion that a denial of the variance sought might deny to the owner a more profitable use of the property, provided the provisions of the ULDR still allow a reasonable use of the property; and*

RESPONSE: The grant of this variance is necessary to avoid practical difficulties or unnecessary hardship and enable the Applicant to maintain the freestanding shade structure with outdoor kitchen. The Gazebo includes a traditional Seminole-style thatched A-frame roof with Sable Palm Leaves. The Gazebo is being utilized as an outdoor kitchen, and the roof is required to have an adequate distance between the barbeque grill and other kitchen equipment to avoid a potential fire hazard, thereby necessitating the height of the structure. The structure has been fire-proofed and approved through fire review during permitting, but extra precautions have been implemented to ensure safety. Similar structures with outdoor kitchens are permitted in this zoning district; however, the aforementioned extra safety measures must be accommodated to safely operate the outdoor kitchen. If the accommodation cannot be implemented, then the Applicant would be deprived of the right to safely operate the outdoor kitchen. Moreover, the Gazebo includes a roof overhang which prevents rain from destroying the kitchen equipment and other electronic devices within the Gazebo.

As previously mentioned, the adjacent properties have similar accessory structures on their properties, which include outdoor kitchens, preparation surfaces, and seating. Most other properties have smaller residences which are located towards the front property line, which allows any accessory structures to be built in the rear yard. However, the Applicant's Property prevents the placement of accessory structures from being developed in the rear yard.

Freestanding shade structures with outdoor kitchens and seating availability are common throughout the River Oaks Neighborhood as the residents of this neighborhood highly regard outdoor recreational activities. Given South Florida's favorable climate, Seminole-style tiki hut structures with outdoor kitchens are enjoyed and utilized by many other property owners through this neighborhood and other residences within the RS-8 zoning district.

d. That the unique hardship is not self-created by the applicant or his predecessors, nor is it the result of mere disregard for, or ignorance of, the provisions of the ULDR or antecedent zoning regulations; and

RESPONSE: This circumstance is a unique hardship. The placement of the principal building is not a self-created hardship as the Applicant purchased the Property in 2019 with this existing configuration. The placement of the Gazebo is due to this unique hardship. Additionally, the height and size result from the need for adequate access and additional safety measures, given the size and positioning of the residence.

e. That the variance is the minimum variance that will make possible a reasonable use of the property and that the variance will be in harmony with the general purposes and intent of the ULDR and the use as varied will not be incompatible with adjoining properties or the surrounding neighborhood or otherwise detrimental to the public welfare.

RESPONSE: The grant of this minimum variance is necessary to avoid practical difficulties or unnecessary hardship and to enable the Applicant to maintain the existing structure. Such an accessory structure may not be essential to the use of a residentially zoned property, but the structure is meant to meet the intent of the City's code. It is not feasible to construct the Gazebo in the rear yard due to the placement of the existing principal single-family residence and corner lot nature.

The Gazebo is not encroaching in any setbacks adjacent neighboring properties. The height is not conflicting with trees or other structures. The size allows for proper stormwater runoff by the roof overhang and best possible circulation. The outdoor kitchen's built-in cabinetry allows for the protection and concealment of all electrical, plumbing, refrigeration equipment and gas lines associated with the outdoor kitchen appliances.

The design is in continuity with the surrounding neighborhood and is not incompatible with the adjoining properties. The property owner has received no complaints or objections from surrounding property owners regarding the design, placement, or any other factor of the Gazebo. Freestanding shade structures and outdoor kitchens are allowed in single-family zoning districts and are harmonious with the River Oaks Neighborhood resident's lifestyle. Therefore, the impact on adjacent properties is de minimus.

We believe denial of this request would create an unnecessary hardship under the facts of this case. Thank you for your consideration and should you have any questions, please do not hesitate to let me know.

Respectfully,

/s/ Stephanie J. Toothaker

Stephanie J. Toothaker, Esq.

Exhibit 1

MEMORANDUM

Date: August 4, 2015

To: Urban Design & Planning Staff

From: Anthony G. Fajardo, Zoning Administrator

Subject: Section 47-19, Accessory Uses, Buildings and Structures

Topic: Outdoor Kitchens/BBQ

Note: This interpretation rescinds the previous interpretation dated December 18, 2002, Subject: Interpretation – **Sec. 47-19.2.P** – Free Standing Shade Structures

Zoning Interpretation:

In recent years there have been several requests for BBQ grills/outdoor kitchens as well as fire pits. Often these are in conflict with the zoning regulations because the principal building is constructed to such an extent that side and rear yard setbacks are maxed out and space is not available. While the intent of the yard setbacks is to control the size of development and to mitigate such development on neighboring properties it is not intended to create a situation where the remainder of the yard becomes unusable. This is evidenced by Section 47-19, Accessory uses, buildings and structures, which permits certain accessory structures to be located within the yard setback subject to certain criteria.

Under specific language in Section 47-19.2, *Accessory buildings, structures and equipment, general*, certain accessory structures are permitted to encroach into the side and rear yards with limitations on area and height. However, as no zoning code can address every situation and permutation of each site and as uses evolve over time it is necessary to reevaluate the aspects of the zoning code in relation to the intent. Given that South Florida has a favorable climate for outdoor activities and the clear intent behind the section indicated above please accept this interpretation regarding the following:

1. Outdoor Kitchens/BBQ:

Whereas Section 47-19.2.P, *Freestanding shade structures* permits structures such as gazebos, tiki huts or trellises no closer than 5-feet from the rear property line or 10-feet when abutting a waterway; and,

Whereas Section 47-19.2.P, *Freestanding shade structures* permits these shade structures to encroach in the rear yard when open on all sides and no more than two hundred (200) gross square feet in area; and,

Whereas Section 47-19.5, *Fences, walls and hedges* permits an opaque fence or wall up to six (6) feet six (6) inches when located a minimum of ten (10) feet from the waterway; and,

Whereas an outdoor kitchen/BBQ have less of an impact than shade structures from a bulk and massing standpoint and tend to be lower than a fence or wall; and,

Whereas an outdoor kitchen/BBQ when incorporated into a shade structure would not enclose the shade structure an outdoor kitchen/BBQ shall be permitted subject to the following standards:

- An outdoor kitchen/BBQ shall be permitted to encroach into the rear yard five (5) feet from the rear property line or ten (10) feet into the rear property line when abutting a waterway. The maximum square footage permitted to encroach shall be no greater than two hundred (200) square feet. An outdoor kitchen/BBQ may incorporate electrical and plumbing for an outdoor sink, refrigeration and gas lines (or similar uses commonly included in an outdoor kitchen) and shall be limited to a maximum height of forty-two (42) inches. The height limitation does not include the lid of the BBQ or grill. A typical grill or BBQ shall be permitted, however no accessories shall be permitted that exceed the height of a typical BBQ or grill lid. An outdoor kitchen/BBQ may be incorporated into a shade structure as long as no one side of the structure is enclosed, and all sides remain open to the outside.



ACCESSORY SHADE STRUCTURE – FACING NORTHWEST



ACCESSORY SHADE STRUCTURE – FACING NORTHWEST



ACCESSORY SHADE STRUCTURE – FACING NORTH



ACCESSORY SHADE STRUCTURE – FACING WEST



ACCESSORY SHADE STRUCTURE – WEST SIDE, FACING NORTH



ACCESSORY SHADE STRUCTURE – FACING NORTHWEST

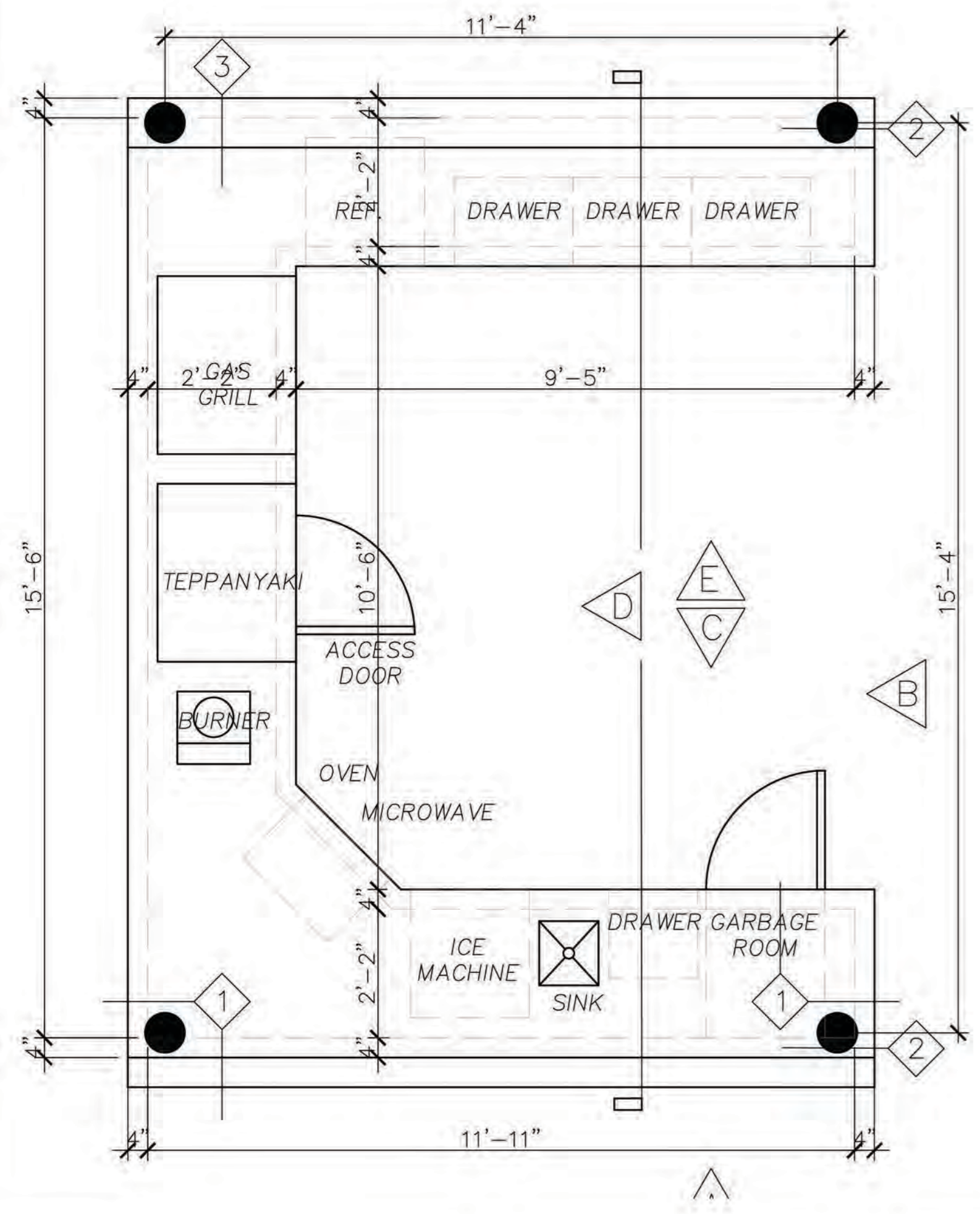

FLOOR PLAN SCALE: 1/2"=1'-0" 1

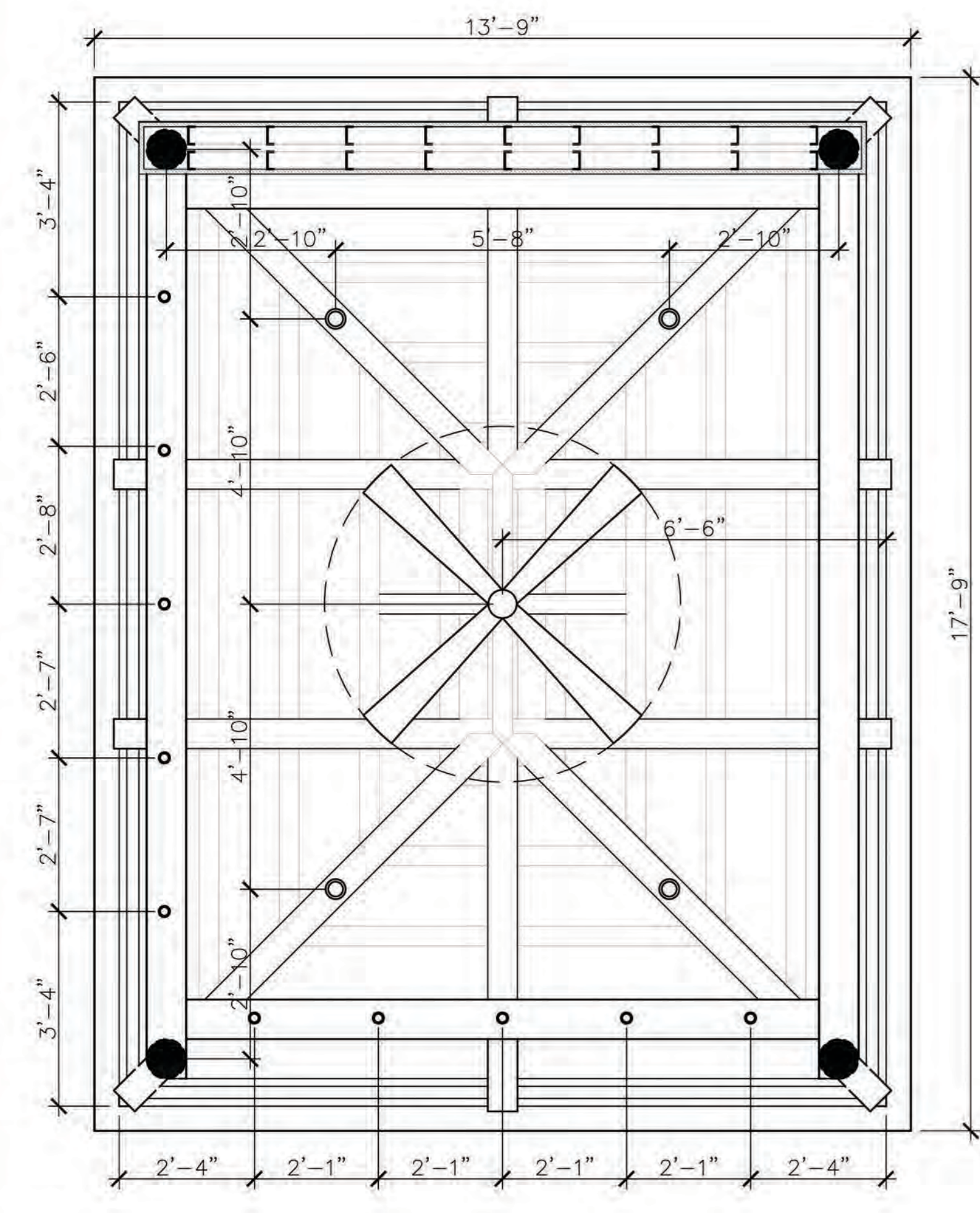

REFLECTED CEILING PLAN SCALE: 1/2"=1'-0" 3

SCOPE OF WORK

1. GAZEBO AND SUMMER KITCHEN 244 SQ. TO BE LEGALIZED.
2. EXISTING CONCRETE SLAB AND STONE FINISH TO REMAIN.
3. POWER AND LIGHTING TO BE CONNECTED TO EXISTING PANEL WITH NEW PROPOSED 20 AMP CIRCUIT BREAKERS.
4. SERVICE SINK SANITARY AND WATER CONNECTED TO EXISTING SERVICE TO BE LEGALIZED.
5. NEW SUMMER KITCHEN ISLAND AND LOWER CABINETS

WALL LEGEND

- 1 NEW 4" CMU WALL W/ 3/4" STUCCO W/ PAINT FINISH TO ONE SIDE AND STONE FINISH TO THE OTHER. PROVIDE #5 @ 32" O.C. IN FILLED CELL 2" EMB. TO EXISTING CONCRETE.
- 2 NEW 12"x12" CMU COLUMN W/ (2) #5. STONE FINISH (SELECTION BY OWNER)
- 3 NEW DEMISING INTERIOR STUD PARTITION WALL OF 4" 20 GA. MTL. STUDS AT 16" O.C. (MAX.) W/ 5/8" WOOD SLAT PANEL EACH SIDE - TO UNDERSIDE TO ROOF STRUCTURE.

REFLECTED CLG. LEGEND:

- RECESSED LIGHT
- JUNCTION BOX

CODE REFERENCE LEGEND:

- FLORIDA BUILDING CODE 2020
- NATIONAL ELECTRIC CODE 2017
- FLORIDA FIRE PREVENTION CODE 7TH EDITION

SCOPE OF WORK AND LEGENDS 2

GENERAL NOTES

1. PERMITS: CONTRACTOR SHALL OBTAIN ALL NECESSARY BUILDING PERMITS, NOT LIMITED, ROOFING, PLUMBING, ELECTRICAL, MECHANICAL, OCCUPANCY AND OTHER PERMITS, AT HIS EXPENSE.
2. QUALIFICATION OF CONTRACTOR: THE GENERAL CONTRACTOR AND ALL SUB-CONTRACTORS SHALL BE LICENSED BY THE STATE OF FLORIDA, AS WELL AS THE COUNTY AND BE INSURED TO MEET THE REQUIREMENTS OF MIAMI-DADE COUNTY AND THE CITY OF MIAMI.
3. OWNER SHALL HAVE THE RIGHT OF APPROVAL OR REJECTION OF ALL SUBCONTRACTORS PRIOR TO SIGNING THE CONTRACT. GENERAL CONTRACTOR SHALL SUBMIT A LIST OF ALL PROPOSED SUBCONTRACTORS AND SUPPLIERS TO THE OWNER FOR HIS PURPOSE.
4. EXISTING CONDITIONS: CONTRACTOR BY AND THROUGH SUBMISSION OF HIS BID, AGREES THAT HE SHALL BE HELD RESPONSIBLE FOR HAVING EXAMINED THE SITE, THE PROPOSED PLANS, THE LOCATION OF ALL PROPOSED WORK AND FOR HAVING SATISFIED HIMSELF FROM HIS OWN PERSONAL KNOWLEDGE AND EXPERIENCE OR PROFESSIONAL ADVICE AS TO THE CHARACTER AND LOCATION OF THE SITE, THE NATURE OF EXISTING CONDITIONS, THE LOCATION OF EXISTING UTILITIES AND ANY OTHER CONDITIONS SURROUNDING AND AFFECTING THE WORK, ANY OBSTRUCTIONS AND ALL OTHER PHYSICAL CHARACTERISTICS OF THE SITE, IN ORDER THAT HE MAY INCLUDE IN HIS PRICE ALL COSTS PERTAINING TO THE WORK AND THEREBY PROVIDE FOR THE SATISFACTORY COMPLETION OF ANY OBJECTS OR OBSTRUCTION WHICH MAY BE ENCOUNTERED IN DOING THE PROPOSED WORK.
5. ALL MEASUREMENTS AND DIMENSIONS MUST BE VERIFIED BY THE CONTRACTOR IN THE FIELD, THE DIMENSIONS SHOWN ARE AS ACCURATE AS THE BASE BUILDING DOCUMENTS PERMIT. ANY DISCREPANCIES MUST BE BROUGHT TO THE ATTENTION OF THE ARCHITECT IMMEDIATELY PRIOR TO THE COMMENCEMENT OF WORK. DO NOT SCALE DRAWINGS - USE DIMENSIONS ONLY. LARGE SCALE DRAWINGS SHALL GOVERN OVER SMALL. IF DIMENSIONS ARE NOT DESIGNATED ON THE PLANS, IT IS THE RESPONSIBILITY OF THE CONTRACTOR TO VERIFY THEM WITH THE ARCHITECT.
6. COMPLY AT ALL TIMES WITH REQUIREMENTS OF THE FLORIDA BUILDING CODE, LIFE AND SAFETY CODE (N.F.P.A. 101), AND ALL LOCAL CODES AND ORDINANCES.
7. SHOP DRAWINGS: THE CONTRACTOR SHALL SUBMIT ONE COPY ON REPRODUCIBLE SEPIA AND FOUR (4) HARD COPIES OF ALL REQUIRED SHOP DRAWINGS CALLED FOR ON THE DRAWINGS OR REQUIRED BY BUILDING OFFICIALS TO THE ARCHITECT IN SUFFICIENT TIME TO BE REVIEWED AND PROCESSED SO AS TO CAUSE NO TIME DELAY IN THE CONSTRUCTION SEQUENCE.
8. PROTECTION: THE CONTRACTOR SHALL PROTECT ADJACENT PARTS OF EXISTING BUILDINGS FROM DAMAGE DURING ALL PHASES OF CONSTRUCTION, AND BE LIABLE FOR SAME.
9. WORKMANSHIP: ALL MATERIALS AND EQUIPMENT SPECIFIED SHALL BE NEW AND ALL WORKMANSHIP SHALL BE FIRST CLASS. FOLLOWING THE MANUFACTURER'S SPECIFICATIONS ALONG WITH THE BEST TRADE PRACTICES AND STANDARDS.
10. ALL WORK TO BE GUARANTEED AGAINST POOR WORKMANSHIP AND DEFECTS.
11. THE GENERAL CONTRACTOR SHALL FURNISH ALL LABOR, MATERIALS AND EQUIPMENT (UNLESS OTHERWISE NOTED) REQUIRED FOR THE COMPLETION OF THE JOB IN ACCORDANCE WITH THESE DRAWINGS.
12. CLEAN UP ALL RUBBISH, REFUSE, SCRAP MATERIALS AND DEBRIS CAUSED BY THIS PROJECT AT THE END OF EACH DAY AND INSURE THAT THE SITE OF WORK SHALL PRESENT A NEAT ORDERLY AND WORKMANLIKE APPEARANCE.
13. GENERAL CONTRACTOR SHALL PRESENT THE JOB TO THE OWNER FOR ACCEPTANCE, CLEANED AND READY FOR OCCUPANCY. ALL GLASS SHALL BE CLEANED AND POLISHED, FLOORS SWEEPED BROOM CLEAN, CARPETS VACUUMED, FIXTURES WASHED AND ALL LABELS REMOVED.
14. STORE MATERIALS IN A SAFE AND APPROVED LOCATION. COMPLY WITH ALL REGULATIONS GOVERNING THE NEIGHBORHOOD AS TO MINIMIZE INTERRUPTIONS AND/OR INTERFERENCE WITH ANY OF THE SURROUNDING OPERATIONS.
15. ALL WOOD IN CONTACT WITH MASONRY SHALL BE PRESSURE TREATED.
16. SOIL IS TO BE TREATED BEFORE POURING CONCRETE SLAB. SECTION 1816 F.B.C.

GENERAL NOTES 4

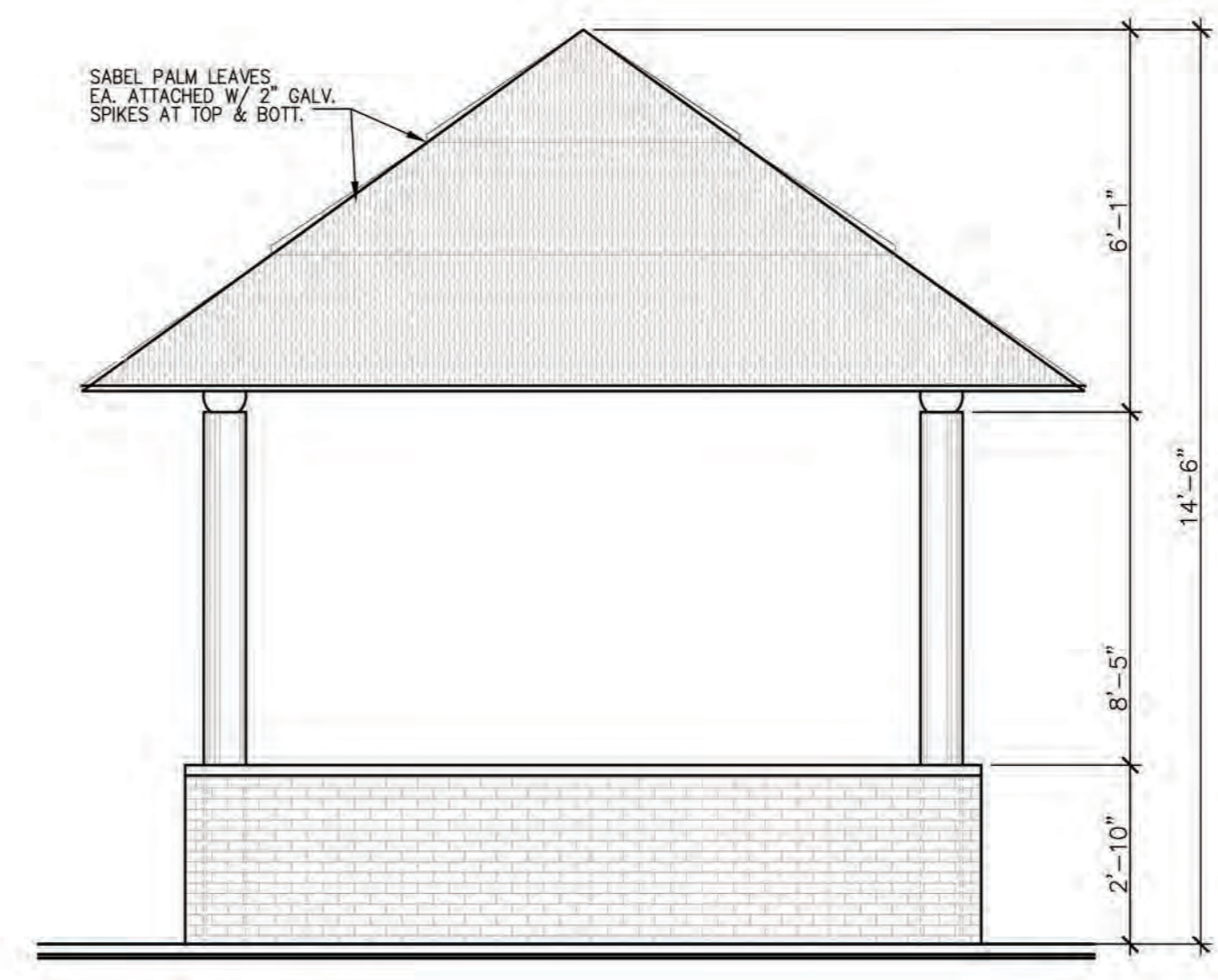

ELEVATION A

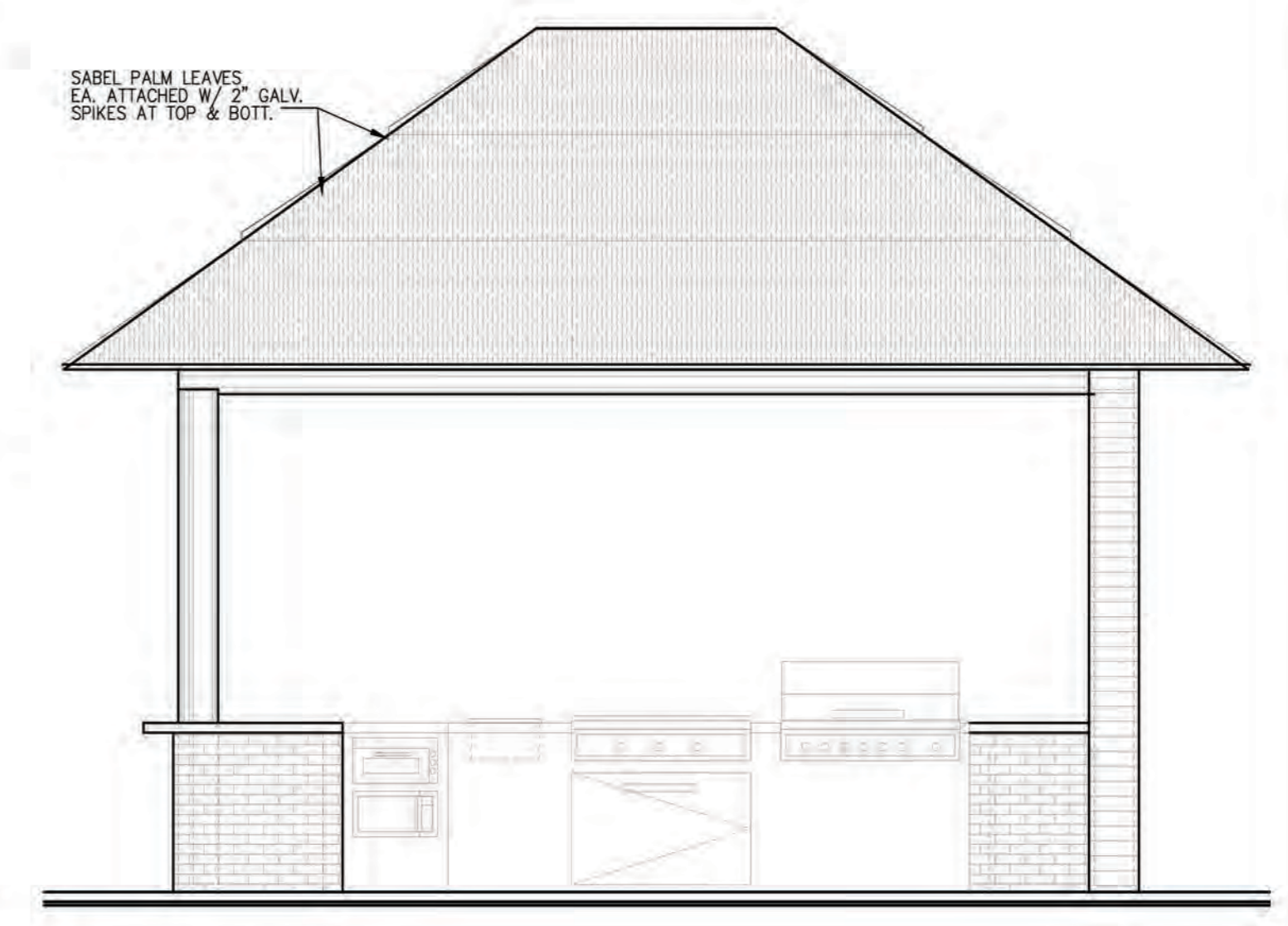

ELEVATION B

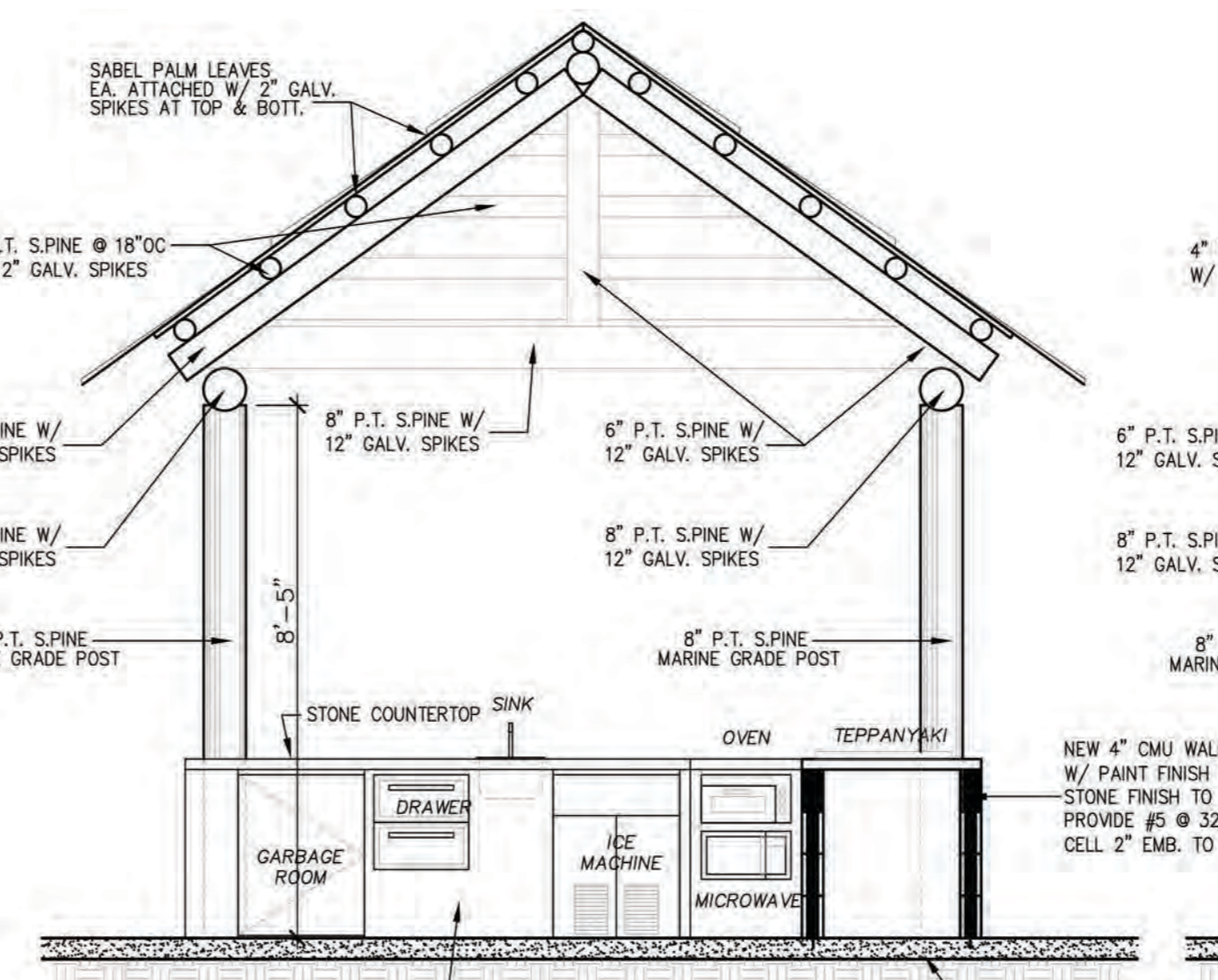

SECTION C

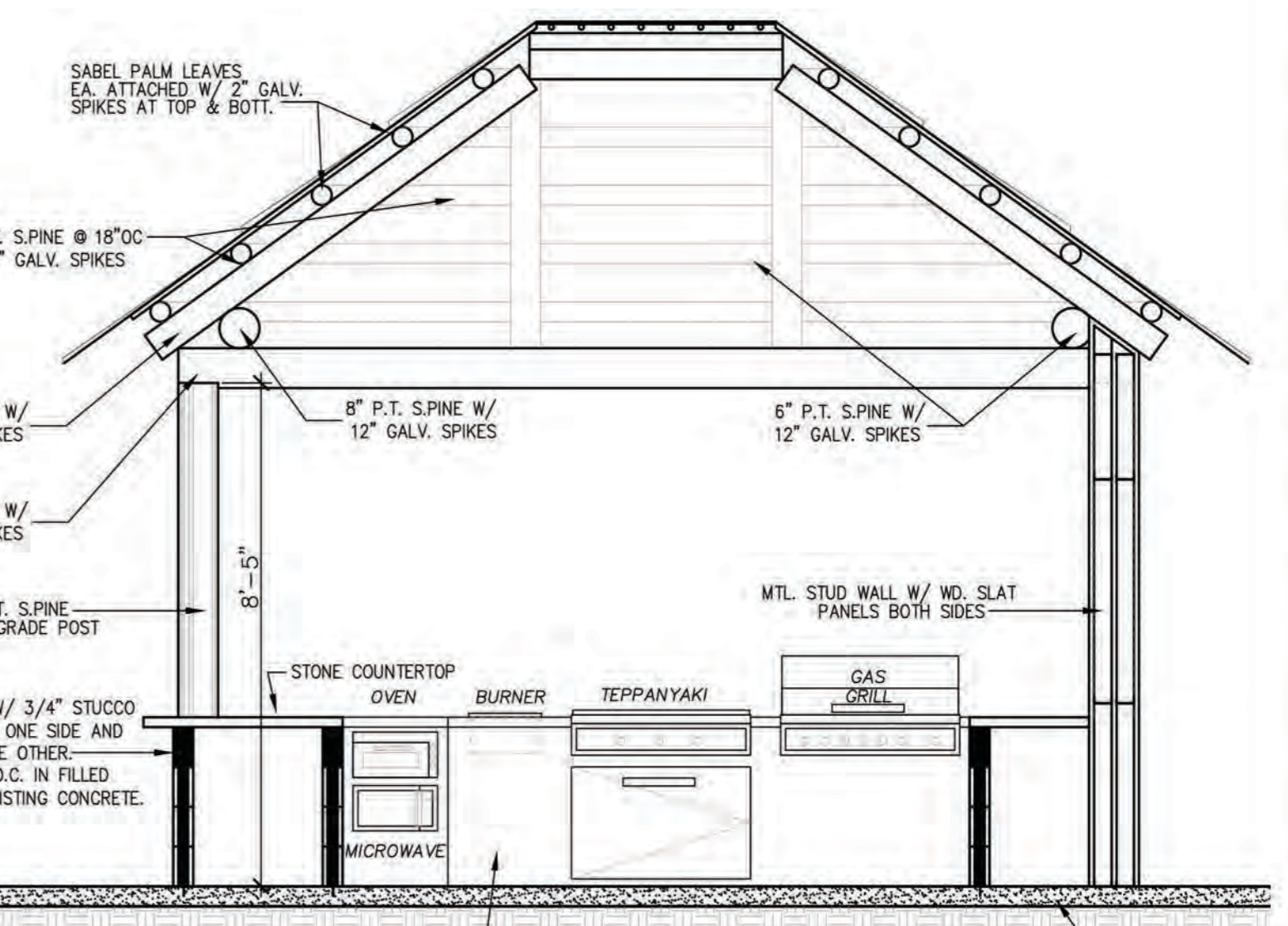

SECTION D

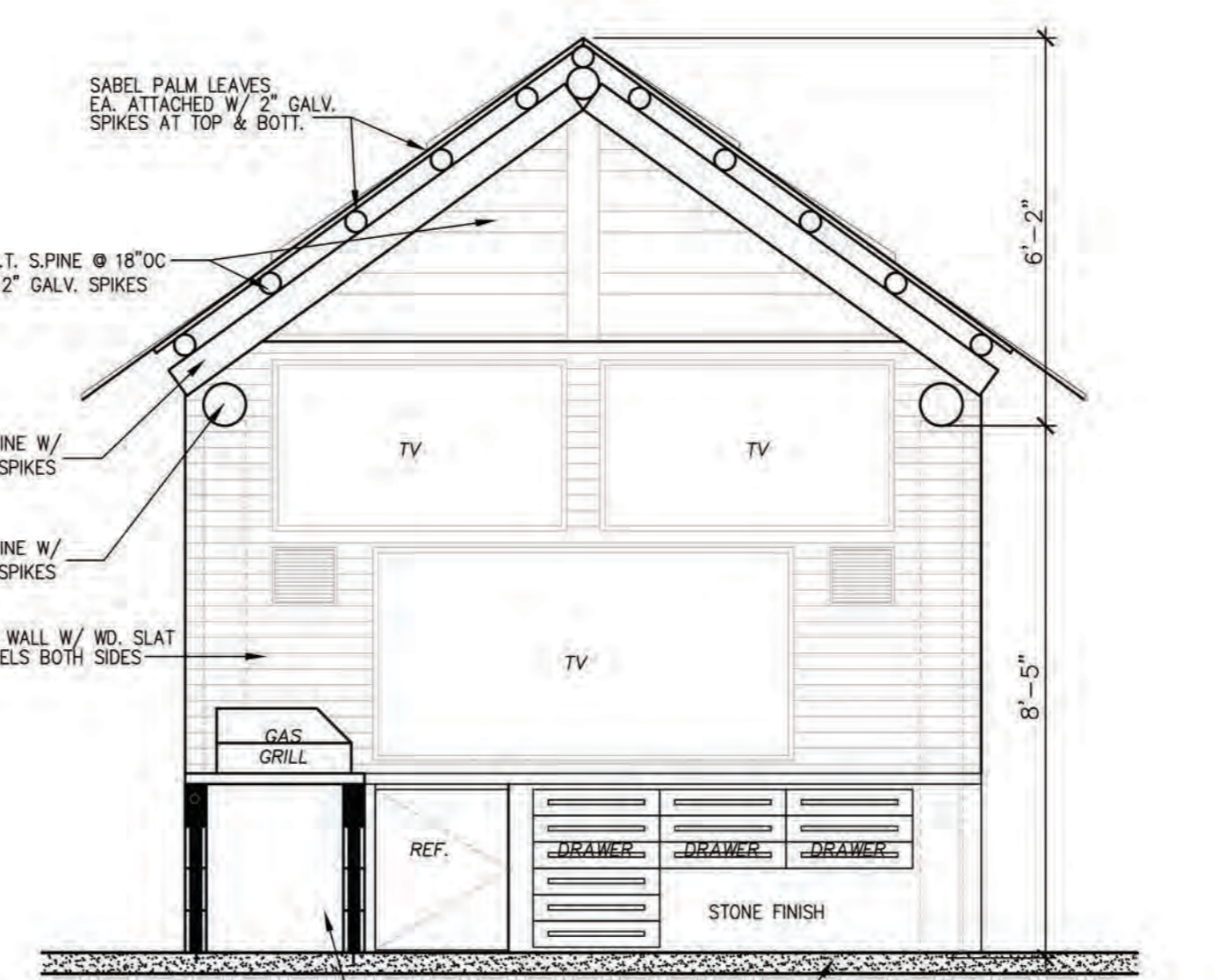

SECTION E

ELEVATIONS AND SECTIONS SCALE: 3/8"=1'-0" 5

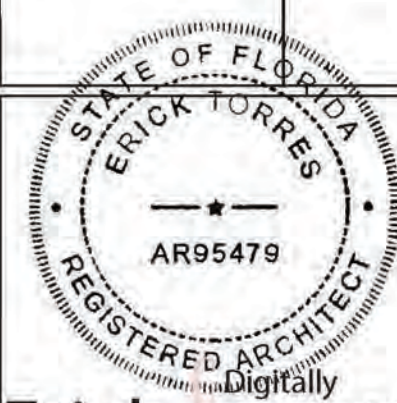

Erick Torres
signed by Erick Torres
Date: 2022.08.03
16:27:02 -0400
SEAL

ARCH. DESIGN:
DRAWN BY: BENJAMIN CABAN
CHECKED BY: ARCH. ERICK TORRES
DATE: MARCH 2020

© ETR COPYRIGHT 2016
THIS DOCUMENT, ITS CONTENT AND CONCEPT ARE THE SOLE PROPERTY OF ETR ARCHITECTURAL WORKSHOP. ITS USE, REPRODUCTION OR MODIFICATION OF ANY OF ITS PARTS OR ITS ENTIRETY ARE EXPRESSLY PROHIBITED, EXCEPT AS ETR MAY AGREE IN WRITING.

MK	DATE	DESCRIPTION
Δ	-	-

SHEET TITLE:

FLOOR AND REFL. CEILING PLAN AND ELEVATIONS

S.W. 18TH COURT

50' R.O.W.
18' ASPHALT PAVEMENT

CABANA TO BE LEGALIZED

SCOPE OF WORK AREA

CABANA TO BE LEGALIZED

LANDSCAPED AREA

70.00'

CABANA TO BE LEGALIZED

ONE STORY RESIDENCE #1400

LOT 1 BLOCK 18

F.F.E.=8.59'
GARAGE ELEV.=7.16'

92'-08"

CONC.

SEPTIC TANK

LANDSCAPED AREA

70.00'

LOT 15 BLOCK 18

LOT 14 BLOCK 18

S.W. 14TH AVENUE

50' R.O.W.

18' ASPHALT PAVEMENT



LEGAL DESCRIPTION:

YELLOWSTONE PARK 23-33 B LOT 1,2 E 20 BLK 18, OF THE PUBLIC RECORDS OF BROWARD COUNTY, FLORIDA.

PROPERTY ADDRESS:

1400 SW 18TH COURT
FORT LAUDERDALE, FL 33315

BUILDING DATA INFORMATION

AREA SUMMARY

GAZEBO TO BE LEGALIZED 204 SQ.FT.(ROOF AREA 244SF)

OVERALL EXISTING RESIDENCE 3,590 SQ.FT.

ZONING DISTRICT

RS-8 (RESIDENCIAL SINGLE-FAMILY DISTRICT)

SITE DEVELOPMENT STANDARDS

1. MINIMUM YARD SETBACKS

YARD	REQUIRED	PROVIDED
A.FRONT	25% LOT WIDTH (17'-6")	2'-10"
B.REAR	15'-0"	106'-0"
C.SIDE		
EAST	5'-0"	48'-11"
WEST	5'-0"	9'-4"

PROJECT TEAM:

ARCHITECT

ETR

CONTACT: BENJAMIN CABAN
ADDRESS: 717 PONCE DE LEON BLVD. #319
CORAL GABLES, FL 33134

PHONE: (786) 715-7731
E-MAIL: arch2bc@yahoo.com

ARCHITECTURAL :

- SP-1: SITE PLAN
- A-1: PROPOSED FLOOR PLAN & NOTES
ELEVATIONS AND SECTIONS
- A-2: LIGHTING, POWER AND PLUMBING
- S-1: FOUNDATION, ROOF PLAN & DETAILS
STRUCTURAL NOTES

NOTES

2

PROJECT LOCATION

1400 SW 18TH COURT
FORT LAUDERDALE, FL 33315



ARCHITECTURAL WORKSHOP
717 PONCE DE LEON BLVD., Suite 319
CORAL GABLES, FL., 33134
(AA20002285)

TEL: (786) 715.7731
arch2bc@yahoo.com

ERICK TORRES
REGISTERED ARCHITECT
LICENSE # AR95479

CONSTRUCTION DRAWINGS FOR:
GAZEBO/SUMMER KITCHEN LEGALIZATION
"EHMKE RESIDENCE"

1400 SW 18TH COURT
FORT LAUDERDALE, FL 33315



signed by Erick Torres
Date: 2022.08.03

16:27:02 -04'00'
SEAL

ARCH. DESIGN:
DRAWN BY: BENJAMIN CABAN
CHECKED BY: ARCH. ERICK TORRES

THIS DOCUMENT, ITS CONTENT AND CONCEPT ARE THE SOLE PROPERTY OF ETR ARCHITECTURAL WORKSHOP. ITS USE, REPRODUCTION OR MODIFICATION OF ANY OF ITS PARTS OR ITS ENTIRETY ARE EXPRESSLY PROHIBITED, EXCEPT AS ETR MAY AGREE IN WRITING.

MK	DATE	DESCRIPTION
Δ	-	-

SHEET TITLE:

SITE PLAN

PROJECT: 21-060
SHEET ID:
SP-1



N.T.S. 3

EXISTING SITE PLAN

SCALE: 3/32"=1'-0"

1

LOCATION MAP

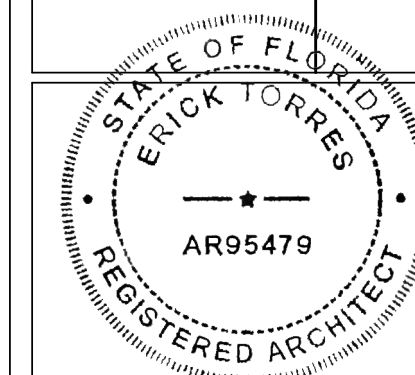

SEAL

ARCH. DESIGN:
DRAWN BY: BENJAMIN CABAN
CHECKED BY: ARCH. ERICK TORRES
DATE: MARCH 2020

© ETR COPYRIGHT 2016
THIS DOCUMENT, ITS CONTENT AND CONCEPT ARE THE SOLE PROPERTY OF ETR ARCHITECTURAL WORKSHOP. ITS USE, REPRODUCTION OR MODIFICATION OF ANY OF ITS PARTS OR ITS ENTIRETY ARE EXPRESSLY PROHIBITED, EXCEPT AS ETR MAY AGREE IN WRITING.

NO.	DATE	DESCRIPTION
1	-	-

SHEET TITLE:

FOUNDATION AND FRAMING PLAN

PROJECT: 21-060

SHEET ID: S-1

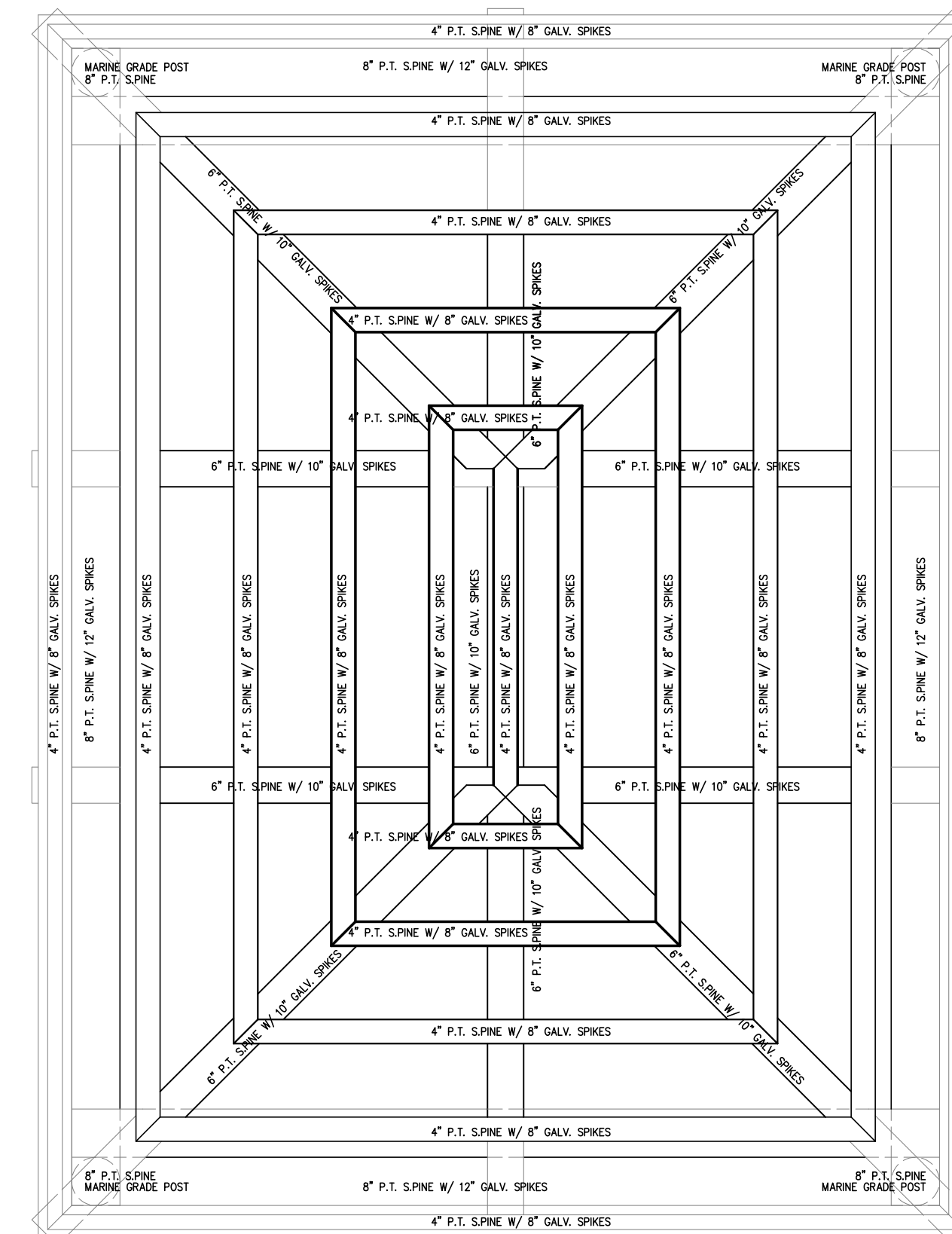

NOTE: ALL WOOD IS CONNECTED WITH 10" TO 6" GALVANIZED SPIKES

POST SCHEDULE				
MARK	SIZE	REINFORCEMENT		REMARKS
		VERTICAL	TIES OR CAP PLATE	
①	8"	TYPE A	-	8" P.T. SOUTHERN PINE MARINE GRADE POST

- ASSUMED DATUM 0'-0" IS EQUAL TO FINISHED FLOOR SLAB. NAVD ELEVATION REFERENCED ON ARCHITL. DWGS.
- INDICATES MASONRY WALL REINFORCED AS FOLLOWS:
#5 VERTICAL PLACED @ EA. CORNER & 40' O.C. FOR EXT. WALLS
#5 VERTICAL PLACED @ 48" O.C. FOR INTERIOR WALLS
(1) #5 VERTICAL PLACED EA. SIDE OF OPENINGS 50" OR LESS.
(2) #5 VERTICAL PLACED EA. SIDE OF OPENINGS 51" OR GREATER.
- CONTRACTOR SHALL VERIFY SIZE AND LOCATION OF OPENINGS W/ ARCHITECTURAL PLANS & WINDOW MFR. SHOP DRAWINGS.
- FOUNDATION SIZE & REINFORCEMENT, MASONRY WALLS AND TIE/BG BEAM REINFORCEMENT AS WELL AS TRUSS AND COLUMN CONNECTIONS HAVE BEEN DESIGNED BY METHOD OF RATIONAL ANALYSIS
- SEE ARCH. PLAN FOR ANY DECORATIVE COLUMNS, STONE/BRICK VENEER SPEC'S, VENEER STONE SHALL BE ATTACHED TO CMU W/ METAL BRICK TIES EVERY 24" VERTICALLY & EVERY 48" MAX. HORIZONTALLY.
- CONTRACTOR SHALL OBTAIN SURVEYOR TO PROVIDE SITE PLACEMENT OF PILES & GRADE BEAMS.

POST EMBEDMENT DETAIL (1 OF 4)

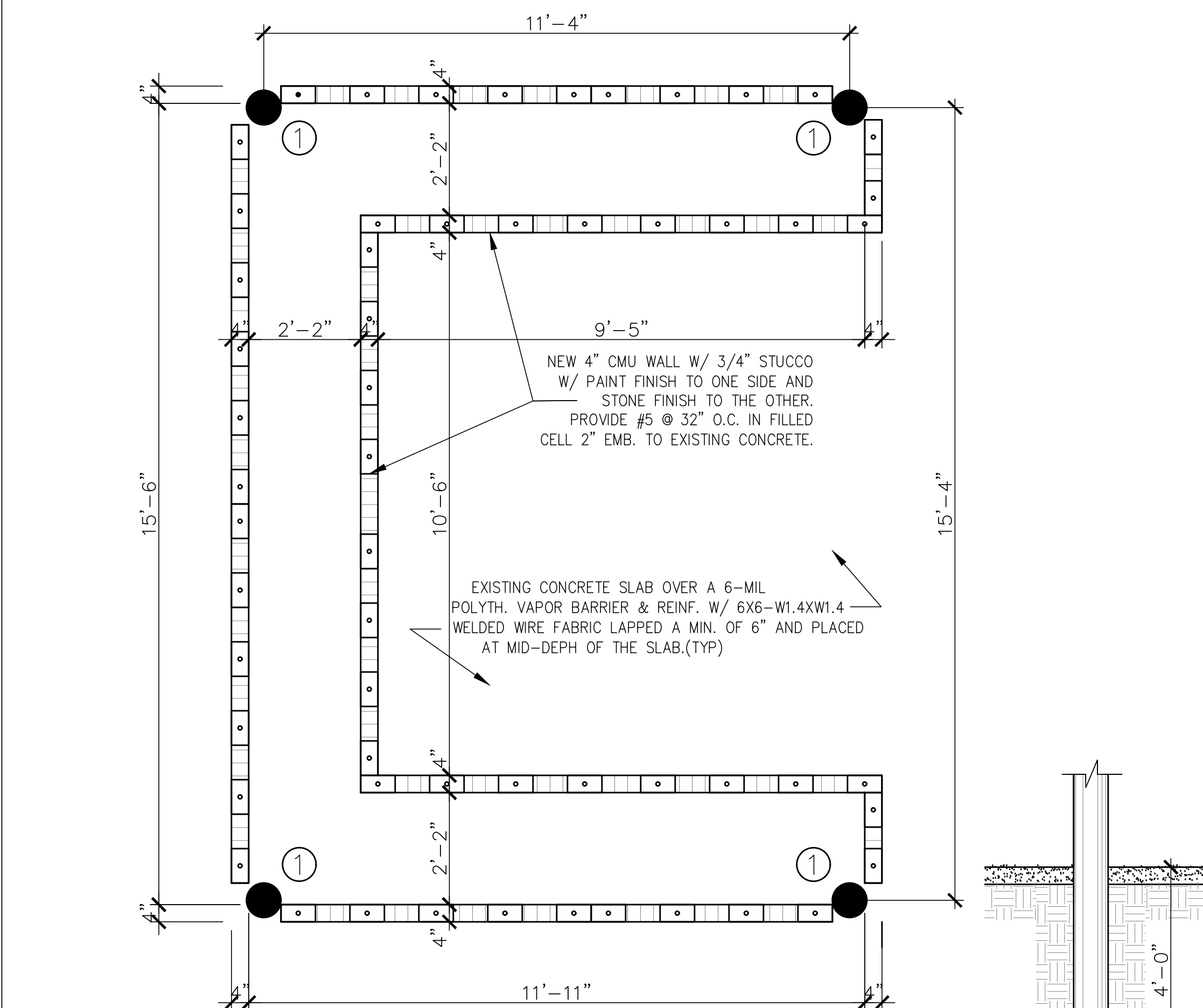

FOUNDATION PLAN SCALE: 1/2"=1'-0" 1

STRUCTURAL NOTES

- DESIGN CRITERIA**
- STRUCTURAL DESIGN IS IN ACCORDANCE WITH THE FOLLOWING CODES AND SPECIFICATIONS:
- FBC, THE FLORIDA BUILDING CODE, 2017 6th EDITION.
 - ASCE 7-10, MINIMUM DESIGN LOADS FOR BUILDINGS AND OTHER STRUCTURES.
 - ACI 318-14, BUILDING CODE REQUIREMENTS FOR STRUCTURAL CONCRETE.
 - AISC, AMERICAN INSTITUTE OF STEEL CONSTRUCTION "SPECIFICATIONS FOR DESIGN, FABRICATION, AND ERECTION OF STEEL FOR BUILDINGS", 13th EDITION.
 - AWG D10 AMERICAN WELDING ASSOCIATION "CODE FOR WELDING IN BUILDING CONSTRUCTION", LATEST EDITION.
 - IN THE EVENT OF CONFLICT BETWEEN PERTINENT CODES AND REGULATIONS AND THE REQUIREMENTS OF THE REFERENCED STANDARDS OF THESE SPECIFICATIONS, THE PROVISIONS OF THE MORE STRINGENT SHALL GOVERN.
 - DESIGN LOADS:
A) WIND LOAD:
BASIC WIND SPEED: 175 MPH
WIND IMPORTANCE FACTOR: 1.00
WIND EXPOSURE: C
INTERNAL PRESSURE COEFFICIENTS: $C_{pi} = \pm 0.18$
 - SITE PREPARATION**
1. COMPACT ALL CONSTRUCTION AREAS WITH A HEAVY SELF PROPELLED VIBRATORY ROLLER TO MINIMUM OF 95% MODIFIED PROCTOR IN ACCORDANCE WITH ASTM D-1557 BUT NOT LESS THAN 10 PASSES IN EACH DIRECTION.
2. BACKFILL CONSTRUCTION AREAS TO REQUIRED ELEVATION IF NEEDED USING CLEAN GRANULAR MATERIAL PLACED IN LIFTS NOT TO EXCEED 12 INCHES IN THICKNESS AND COMPACT AS INDICATED IN ITEMS 2. EXCAVATE FOOTING AREAS ONLY IF NEEDED TO PROPER DEPTH AND RECOMPACT USING HAND HELD EQUIPMENT AS INDICATED ABOVE.
3. CARE SHOULD BE TAKEN NOT USE VIBRATION IN CASE OF EXISTING STRUCTURES IN THE VICINITY OF THE CONSTRUCTION AREA. IF VIBRATION CAN NOT BE USED FOR COMPACTION, STATIC COMPACTION MAY BE APPLIED. HOWEVER, IN THE CASE, THE COMPACTED LAYER SHOULD NOT EXCEED 4" IN THICKNESS.
4. ALL CONSTRUCTION FILL MATERIAL SHALL BE CLEAN GRANULAR SOIL, FREE OF ORGANICS OR OTHER DELETERIOUS MATERIAL AND SHALL CONTAIN NO MORE THAN FIVE PERCENT FINES PASSING A U.S. STANDARD NO. 200 SIEVE. (CLASSIFIED AS SW/CW)
5. VERIFY ALL COMPACTION EFFORTS BY TAKING AN ADEQUATE NUMBER OF FIELD DENSITY TEST IN EACH LAYER OF COMPACTED MATERIAL AND IN EACH FOOTING PAD.
6. REPRESENTATIVE SAMPLES OF THE ON-SITE AND PROPOSED FILL MATERIAL SHALL BE COLLECTED AND TESTED TO DETERMINE THE CLASSIFICATION AND COMPACTION CHARACTERISTICS.
7. ALL GEOTECHNICAL WORK MUST BE PERFORMED UNDER THE SUPERVISION OF THE GEOTECHNICAL ENGINEER OR HIS REPRESENTATIVE TO VERIFY COMPLIANCE WITH OUR SPECIFICATIONS AND THE FLORIDA BUILDING CODE.
8. IN THE EVENT OF EXISTING STRUCTURES, EXISTING FOOTING OR PROPOSED DRAINAGE LINES, PROVISIONS SHALL BE MADE BY THE STRUCTURAL ENGINEER AND SITE CONTRACTOR TO PROTECT ALL FOOTINGS FROM UNDERMINING AND EXPOSURE. THE GEOTECHNICAL ENGINEER SHALL BE NOTIFIED OF THESE CONDITIONS TO EVALUATE THE APPLICABILITY OF HIS RECOMMENDATIONS.
 - FOUNDATION**
1. FOOTINGS HAVE BEEN DESIGNED FOR 2,000 P.S.F. ALLOWABLE SOIL BEARING CAPACITY. PRIOR TO THE INSTALLATION OF ANY FOOTING FOUNDATION SYSTEM FOR NEW BUILDINGS, STRUCTURES OR ADDITIONS, THE BUILDING OFFICIAL SHALL BE PROVIDED WITH A STATEMENT OF ALLOWABLE BEARING CAPACITY FROM AN ARCHITECT OR PROFESSIONAL ENGINEER. SAID STATEMENT SHALL INCLUDE THE ALLOWABLE IN-PLACE BEARING CAPACITY OF THE FOOTING PAD FOR THE NEW BUILDING OR ADDITION AND VERIFY THE EXISTING SOIL CONDITIONS THE CERTIFIED IN-PLACE BEARING CAPACITY SHALL HAVE BEEN DETERMINED BY WAY OF RECOGNIZED TESTS OR RATIONAL ANALYSIS AND SHALL MEET OR EXCEED THE DESIGN BEARING CAPACITY.
2. ALL FOOTING EXCAVATION AND COMPACTION SHALL BE INSPECTED AND APPROVED BY THE GEOTECHNICAL ENGINEER FOR THE BEARING CAPACITY INDICATED ABOVE PRIOR TO CONCRETE PLACEMENT.
3. FOOTINGS SHALL BE FOUND ON WELL COMPACTED VIRGIN SOIL OR ON ENGINEERED FILL AT THE ELEVATIONS SHOWN.
4. KEEP FOUNDATION EXCAVATIONS FREE OF WATER AT ALL TIMES. REPLACE SOFT OR WEAKENED SOIL WITH STRUCTURAL FILL.
5. ELEVATIONS SHOWN AT FOOTINGS ARE TOP OF FOOTING ELEVATION (T.O.F.).
6. ALL EXTERIOR FOOTINGS TO BEAR MINIMUM 2'-0" BELOW ADJACENT GRADE, UNLESS OTHERWISE NOTED. ADJUST BOTTOM OF FOOTING AS REQUIRED.
7. FOR CORNER WALL FOOTINGS, SPLICES IN REINFORCING BARS SHALL NOT BE LESS THAN (4) BAR DIAMETERS AND REINFORCEMENT SHALL BE CONTINUOUS AROUND ALL CORNERS AND CHANGES IN DIRECTION. CONTINUITY

STRUCTURAL NOTES

STRUCTURAL SCHEDULES 2

- CONCRETE CONSTRUCTION NOTES**
- CAST-IN-PLACE CONCRETE SHALL ATTAIN THE FOLLOWING MINIMUM 28-DAY COMPRESSIVE STRENGTHS (F_c):
A. FOOTINGS AND SLAB ON GRADE: 4,000 psi
B. ALL OTHER CONCRETE: 4,000 psi
 - CONCRETE DENSITY SHALL BE NORMAL WEIGHT UNLESS SPECIFICALLY OTHERWISE NOTED.
 - ALL CONCRETE SHALL BE "READY MIXED" AND IN ACCORDANCE WITH ASTM SPECIFICATIONS C-94 A CERTIFICATE, MANUFACTURERS MIX AND STRENGTH IS TO BE PROVIDED AND HAVE A MINIMUM OF 320 LBS OF CEMENT PER CUBIC YARD. NO WATER TO BE ADDED AFTER TRUCK LEAVES PLANT WITHOUT APPROVAL OF ENGINEER OR PLANT ENGINEER. PLANT CONTROL IS REQUIRED. MAXIMUM MIX TIME AT POINT OF DEPOSIT IS 90 MINUTES. CONTRACTOR SHALL SUBMIT CONCRETE MIX DESIGN FOR REVIEW AND APPROVAL.
 - CONCRETE REINFORCING STEEL SHALL BE DEFORMED BARS CONFORMING TO ASTM A615/A615M, GRADE 60. WELDED WIRE FABRIC SHALL CONFORM TO ASTM A185. PROVIDE SHEET-TYPE WELDED WIRE FABRIC. SHEET LAPS SHALL BE TIED AND LAPPED ONE FULL MESH SPACING. CONTRACTOR SHALL SUBMIT SHOP DRAWINGS FOR REVIEW AND APPROVAL.
 - CONCRETE REINFORCING STEEL SHALL BE CONTINUOUS UNLESS OTHERWISE INDICATED. CONTINUOUS REINFORCING STEEL SHALL BE LAPPED IN ACCORDANCE WITH THE REQUIREMENTS OF ACI 318.
 - MINIMUM CONCRETE COVER FOR REINFORCING STEEL SHALL BE AS INDICATED. IN NO CASE SHALL REINFORCEMENT COVER BE LESS THAN THE REQUIREMENTS OF ACI 301.
A) CONCRETE CAST AGAINST AND PERMANENTLY EXPOSED TO EARTH: 3"
B) CONCRETE EXPOSED TO EARTH OR WEATHER: 2"
No.5 BARS AND SMALLER: 1 1/2"
C) CONCRETE NOT EXPOSED TO WEATHER OR IN CONTACT WITH EARTH: 1 1/2"
BEAMS AND COLUMNS: 1 1/2"
 - CONCRETE REINFORCING STEEL MARKED STANDARD HOOK SHALL HAVE A 90 DEGREE HOOK WITH A MINIMUM COMPRESSIVE STRENGTH OF 3,000 PSI, SLUMP 9 IN. AND 180-DEGREE HOOKS SHALL CONFORM TO THE REQUIREMENTS OF ACI 318.
 - PROVIDE 3/4" THICK JOINT FILLER MATERIAL WHERE SLABS ON GRADE ABUT VERTICAL SURFACES.
 - REINFORCING STEEL SHALL BE SPREAD AT SLEEVES, TIEBACKS, RECESSES AND OTHER EMBEDDED ITEMS WHICH ARE INDICATED. REINFORCEMENT SHALL NOT BE CUT TO FACILITATE PLACEMENT OF EMBEDDED ITEMS.
 - ALL EXPOSED CONCRETE EDGES SHALL BE CHAMFERED 3/4" O.U.N.
 - ALUMINUM SHALL NOT BE PLACED IN DIRECT CONTACT WITH CONCRETE UNLESS EFFECTIVELY COATED OR UNLESS EFFECTIVELY COATED OR COVERED TO PREVENT ALUMINUM-CEMENT REACTION AND ELECTROLYTIC ACTION BETWEEN ALUMINUM AND STEEL.
 - ALUMINUM CONDUITS, PIPES, AND ACCESSORIES SHALL NOT BE EMBEDDED IN MASONRY GROUT, OR MORTAR, UNLESS EFFECTIVELY COATED OR COVERED TO PREVENT ALUMINUM-CEMENT REACTION OR ELECTROLYTIC REACTION BETWEEN ALUMINUM AND STEEL.
 - CONVERT VERTICAL REBARS ACCORDING TO PLAN OR WALL SCHEDULE. SEE "TYPICAL WALL END AND CORNER DETAILS" FOR SPECIAL REINFORCING DETAIL.
 - VERTICAL REINFORCEMENT MUST HAVE A MINIMUM #8 BAR DIAMETER LAP SPLICE UNLESS OTHERWISE NOTED. CENTER WALL REINFORCEMENT IN BLOCK CELLS. USE NONMETALLIC BAR POSITIONERS.
 - PROVIDE DOWEL REINFORCEMENT IN FOUNDATION OF SAME SIZE AND SPACING AS VERTICAL WALL REINFORCEMENT.
 - BRACE TOP OF INTERIOR, NON-LOAD BEARING MASONRY WALLS TERMINATING AT THE UNDERSIDE OF FLOOR OR ROOF STRUCTURE AGAINST OUT-OF-PLANE MOVEMENT IN ACCORDANCE WITH THE TYPICAL NON-BEARING CMU WALL BRACING DETAIL.
 - PROVIDE CONCRETE LINTEL AND WINDOW SILL ACCORDING TO SCHEDULES IN TYPICAL OPENING DETAIL.
- CONCRETE COLUMNS AND SLUMPS TESTS**
- AT LEAST ONE SET OF CYLINDERS SHALL BE PROVIDED FOR STRENGTH AND SLUMP TESTS PER POUR OR FOR EACH 50 CUBIC YARDS OF CONCRETE, WHICHEVER IS LESS. AT LEAST TWO SETS OF TESTS ARE RECOMMENDED FOR COLUMN POURS. FOR EACH POUR THE ENGINEER SHALL BE PROVIDED WITH ONE (1) 7-DAY BREAK, ONE (2) 28-DAY BREAKS, ONE (1) RESERVED CYLINDER.
- TIMBER:**
- ALL LUMBER SHALL BE #2 OR BETTER GRADE SOUTHERN PINE. ALLOWABLE STRESSES SHALL BE AS INDICATED IN "DESIGN VALUES FOR WOOD CONSTRUCTION", A SUPPLEMENT TO THE "NATIONAL DESIGN SPECIFICATION (NDS) FOR WOOD CONSTRUCTION" 2005 EDITION, BY THE AMERICAN FOREST AND PAPER ASSOCIATION. ALLOWABLE MAXIMUM WATER CONTENT SHALL BE 19%.
 - ALL WOOD IN DIRECT CONTACT WITH CONCRETE OR MASONRY SHALL BE NATURALLY DURABLE SPECIES, OR PRESERVATIVE TREATED WOOD PER AMERICAN WOOD PRESERVATIVE ASSOCIATION (AWPA).
 - ALL FASTENER (E.G. NAILS, SCREWS, BOLTS, ANCHOR BOLTS) SHALL BE HOT-DIPPED GALVANIZED (660 MINIMUM GALVANIZED COATING) OR 300 SERIES STAINLESS STEEL.
 - CONNECTORS STEEL SHALL CONFORM TO ASTM A563 AND SHALL BE HOT-DIP GALVANIZED PER ASTM A525 OR 300 SERIES STAINLESS STEEL.
 - FASTENERS AND CONNECTORS USED TOGETHER SHALL BE OF THE SAME.
 - ALL CUTS, HOLES AND INJURIES TO THE SURFACE OF TREATED WOOD SHALL BE PROTECTED BY FIELD TREATMENT MEETING AWPA STANDARD M4.
 - ALL TREATED WOOD PRODUCTS SHALL BE HANDLED AND FIELD FABRICATED IN ACCORDANCE WITH AWPA STANDARD M4 FOR THE CARE OF PRESERVATIVE TREATED WOOD PRODUCTS.

STRUCTURAL SCHEDULES

FRAMING PLAN SCALE: 1/4"=1'-0" 3

PLYWOOD ROOF SHEAR DIAPHRAGM SCHEDULE						
PANEL GRADE	FRAMING JOIST SPACING	MINIMUM PANEL THICKNESS	NAIL SPACING		COMMON NAIL SIZE	REMARKS
ROOF	APA RATED SHEATHING EXPOSURE 1	2'-0" O.C.	19/32" NOM.	6" O.C.	6" O.C.	8d RING SHANK NAILS SEE NOTE 4 BELOW

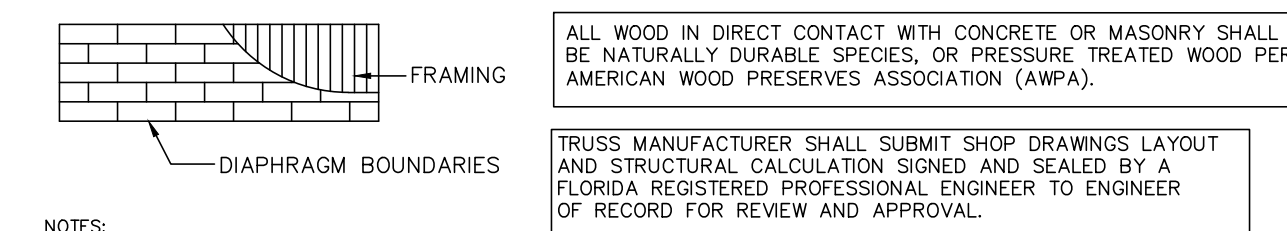

ALL WOOD IN DIRECT CONTACT WITH CONCRETE OR MASONRY SHALL BE NATURALLY DURABLE SPECIES, OR PRESERVATIVE TREATED WOOD PER AMERICAN WOOD PRESERVATIVE ASSOCIATION (AWPA).

TRUSS MANUFACTURER SHALL SUBMIT SHOP DRAWINGS LAYOUT AND STRUCTURAL CALCULATION SIGNED AND SEALED BY A FLORIDA REGISTERED PROFESSIONAL ENGINEER TO ENGINEER OF RECORD FOR REVIEW AND APPROVAL.

- ROOF NOTES:**
- ROOF DECKING TO BE PLYWOOD 19/32" THICK CD EXTERIOR GRADE FASTENED TO TRUSS TOP CHORDS W/ 8d RING SHANK NAILS @ 6" O.C. IN THE FIELD & 4" O.C. AT EDGES TYPICAL.
 - PLYWOOD CONNECTOR TO BE Nu-Vue NWH24 22 CONNECTORS W/10-10d x 1 1/2" NAILS INTO SEAT & 10-10d x 1 1/2" NAILS INTO TRUSS UNLESS OTHERWISE NOTED. UPLIFT = 2259 LBS. PARALLEL HORIZONTAL LOAD L1 = 1575 LBS & PERPENDICULAR HORIZONTAL LOAD L2 = 2175 LBS. N.O.A. 08-0325.02
 - ANCHOR ALL WEB AND BOTTOM CHORD BRACING TO THE MASONRY WALL AS PER TYPICAL DETAILS ON THIS DWG.
 - PROVIDE CORNERS BARS IN ALL CONCRETE BEAMS AND THE BEAMS @ ALL 90° CORNERS SAME SIZE AS BEAM REINFORCING TYP.

- BRACING NOTES:**
- PERMANENT WEB AND HORIZONTAL LATERAL BRACING SHALL BE INSTALLED ACCORDING TO INDIVIDUAL TRUSS DRAWING. REFER TO SHOP DRAWINGS. (WEB AND LATERAL BRACING ARE NOT SHOWN ON ROOF FRAMING PLAN). PERMANENT WEB AND HORIZONTAL LATERAL BRACING IS RESTRAINED TO PREVENT LATERAL MOVEMENT BY SOLID ANCHORAGE TO END WALLS, OR BY PERMANENT DIAGONAL BRACING IN THE PLANE OF THE WEB MEMBER AT INTERVALS NOT TO EXCEED TWENTY (20) FEET ALONG CONTINUOUS WEB BRACE. (REF: HB-91, SEC. 1323.1 AND DETAILS ON SHEET 5-).

FRAMING PLAN

4

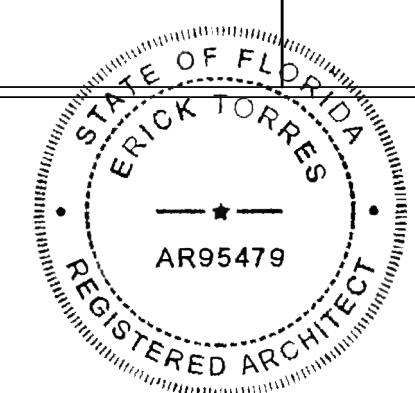

MK	DATE	DESCRIPTION
1	4-2-2022	CITY

ELECTRICAL LEGEND

- ⊕ DUPLEX RECEPTACLE
 - ⊕ WP GFI WATER PROOF
 - ⊕ 220 VOLTS
 - ⊕ SPECIAL RECEPTACLE
 - ⊕ SWITCH
 - ⊕ JUNCTION BOX IN CLG
 - ⊕ LED LIGHTING (WALL MOUNTED)
 - ⊕ INCANDESCANT LIGHTING (PENDANT)
 - ⊕ LED RECESSED LIGHTING HI-HATS, ETC.
 - ⊕ FLOOD LIGHTS
- ER EXISTING TO REMAIN
REL EXISTING TO BE RELOCATED
REM EXISTING TO BE REMOVED

- ELECTRICAL NOTES**
- GENERAL. ALL ELECTRICAL WORK SHALL CONFORM TO THE FBC 2017, 6th EDITION, CHAPTER 27; ALSO COMPLY WITH NEC 2014; NFPA70 AND; LOCAL CODES. ALL MATERIALS SHALL BEAR UNDERWRITERS LABORATORY LABEL OR BE U.L. LISTED. WORKMANSHIP SHALL BE IN ACCORDANCE WITH GOOD TRADE PRACTICES. ALL EXCAVATING AND BACKFILLING REQUIRED FOR ELECTRICAL WORK SHALL BE THE RESPONSIBILITY OF THE ELECTRICAL SUBCONTRACTOR.
 - THE FOLLOWING CONDUCTORS AND RACEWAYS SHALL BE INSTALLED:
A. ALL CONDUCTORS TO BE COPPER WITH 90 DEGREE C RATED INSULATION TYPE THHN.
B. EXTERIOR RACEWAYS, BOXES, COVER PLATES, ETC. SHALL BE WEATHERPROOF CONST.
 - THE FOLLOWING DEVICES SHALL BE USED:
A. ALL DEVICES SHALL BE RATED FOR THE RATING OF THE CIRCUIT BREAKER SERVING SUCH DEVICES *30 AMP BREAKERS SHALL SERVE 30 AMP DEVICES, ETC.
B. PROVIDE GFI DEVICES AS INDICATED.
C. DISCONNECT SWITCHES SHALL BE SQUARE D, GENERAL DUTY CLASS 3130, OR EQUAL ITE OR GE PRODUCT. PROVIDE TYPE 3R ENCLOSURE FOR EXTERIOR SERVICE AND TYPE 1 ENCLOSURE FOR INTERIOR SERVICE.
D. STANDARD DEVICES ARE AS FOLLOWS (PASS & SEYMOUR OR EQUAL):
*20A SWITCHES - 20A SERIES.
*COVER PLATES - STANDARD WHITE.
 - OVERHEAD ELECTRIC CONDUCTOR CLEARANCES, HORIZONTAL AND VERTICAL SHALL BE MAINTAINED.
 - BATHROOM, KITCHEN, GARAGE AND EXTERIOR RECEPTACLES SHALL BE WEATHER RESISTANT WITH GROUND FAULT INTERRUPTERS, AND INSTALLED IN WEATHERPROOF ENCLOSURE..
 - ELECTRICAL INSTALLATION DESIGN IS IN COMPLIANCE AS SET FORTH BY THE STATE OF FLORIDA MODEL ENERGY EFFICIENCY CODES.
 - SMOKE DETECTORS SHALL BE HARD WIRED (110 VOLT) TO A NON-SWITCHABLE KITCHEN OR BATHROOM LIGHTING CIRCUIT AND SHALL NOT BE CONNECTED ONTO THE LOAD SIDE OF A GROUND INTERRUPTOR. S/D SHALL BE INTERCONNECTED FOR ALARM & SHALL HAVE BATTERY BACK-UP.
 - VERIFY EXACT LOCATION OF ELECTRICAL OUTLETS AND LIGHTS PRIOR TO EXECUTION OF ROUGH-IN WORK.
 - ALL RACEWAYS AND NON-CURRENT CARRY METAL ENCLOSURES SHALL BE MECHANICALLY AND ELECTRICALLY GROUNDED.
 - ALL RACEWAYS IN FINISHED AREAS SHALL BE CONCEALED AND ALL OUTLETS IN FINISHED AREAS SHALL BE CONCEALED AND MOUNTED FLUSH WITH FINISHED WALLS.
 - ALL WORK SHALL BE RIGIDLY MOUNTED AND SUPPORTED.
 - ELECTRICAL OUTLETS, RECEPTACLES AND LIGHTING: BELOW BASE FLOOD ELEVATION SHALL BE INSTALLED AT HIGHEST PERMITTED ELEVATION AND SHALL BE INSTALLED ON A SEPARATE INDEPENDANT CIRCUIT FROM THOSE IN HABITABLE AREAS.
 - NO APPLIANCE OUTLETS SHALL BE INSTALLED BELOW THE BASE FLOOD ELEVATION.
 - MAIN CIRCUIT BREAKER SHALL BE INSTALLED ABOVE THE BASE FLOOD ELEVATION.
 - ALL 120V, SINGLE PHASE 15- AND 20-AMPERE BRANCH CIRCUIT SUPPLYING OUTLETS INSTALLED IN DWELLING UNITS SHALL BE PROTECTED BY A LISTED ARC-FAULT CIRCUIT INTERRUPTER, COMBINATION TYPE CIRCUIT BREAKER INCLUDING THE KITCHEN AND LAUNDRY ROOM.
 - ALL 15- AND 20-AMPS OUTLET RECEPTACLES SHALL BE TAMPER RESISITANT.
 - AT LEAST 75% OF ALL FIXTURES, LAMPS AND LIGHT BULBS SHALL BE ENERGY EFFICIENT.
 - ALL LUMINARIES SHALL BE UL LISTED AND WHEN RECESSED IN CEILING SHALL BE IC RATED.
 - ALL SMOKE ALARMS (EXISTING AND NEW) SHALL COMPLY WITH FBC 314 FOR SMOKE ALARMS.
 - ALL RECEPTACLES AT BATH AND KITCHEN SHALL COMPLY WITH NEC 210.8.

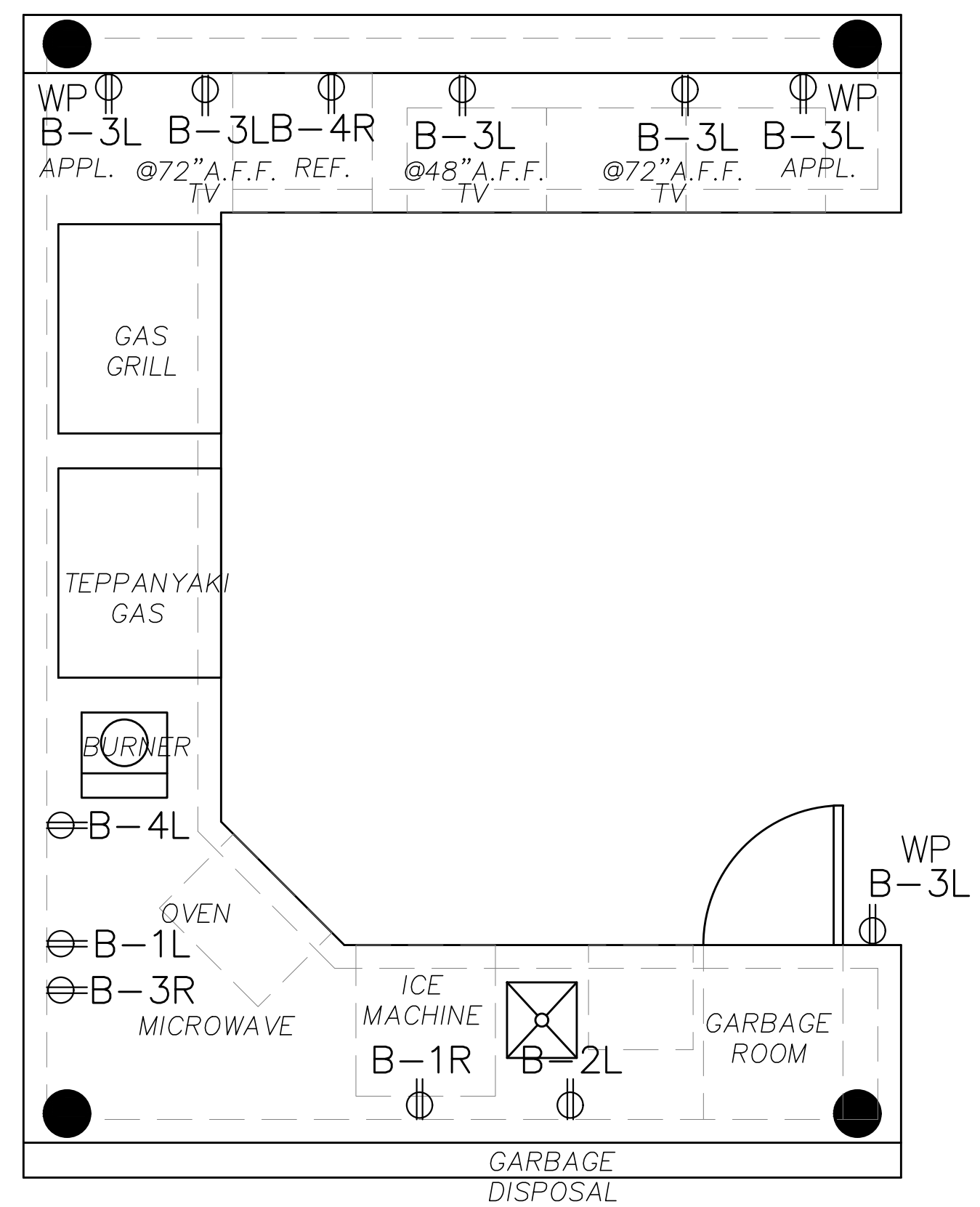
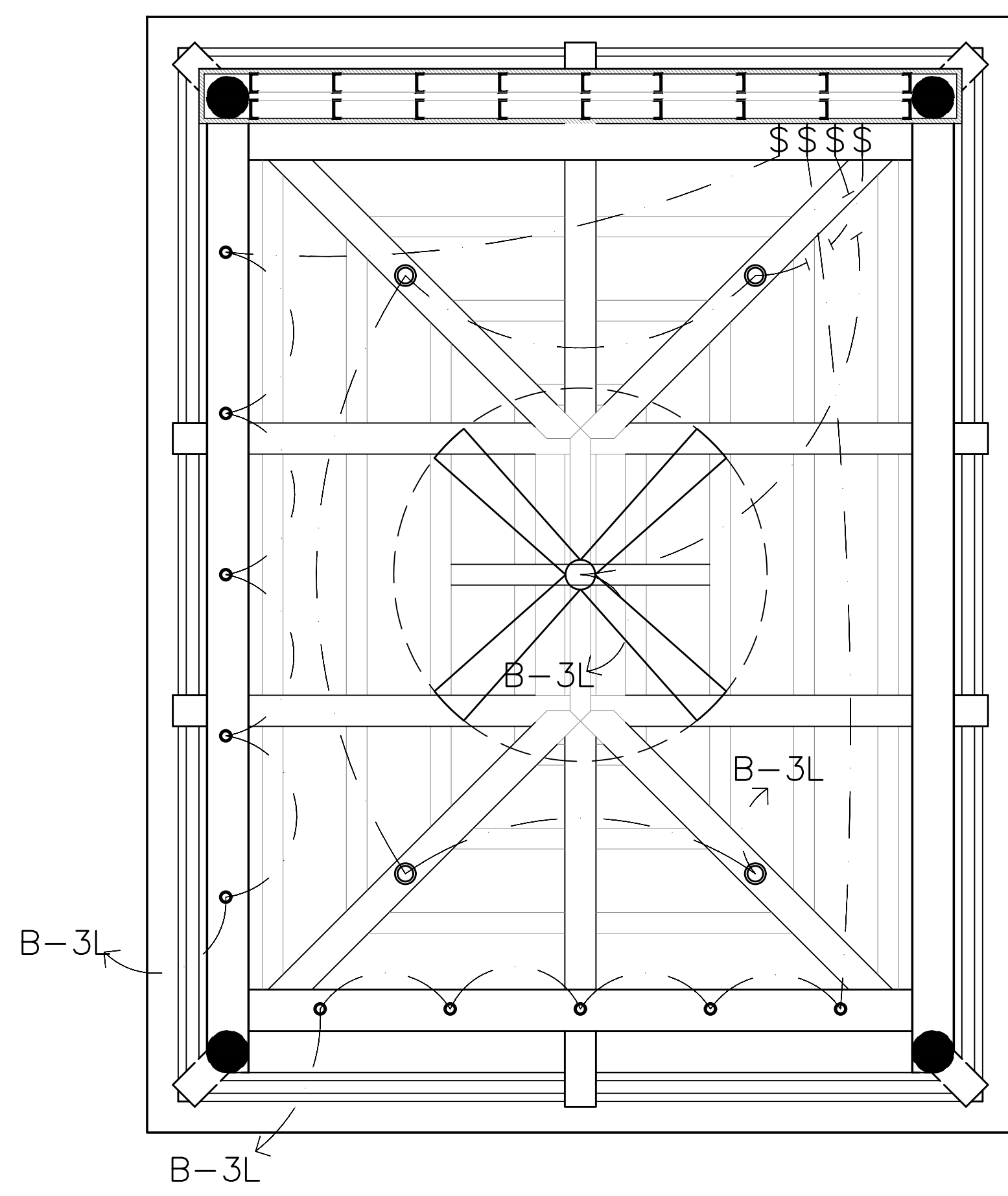

TYPE: EXISTING
SERVICE: 36_4W
VOLTAGE: 120/208V.
MOUNTING: SUBFACE

EXISTING PANEL "A"
10 KAIC
NEMA 1

MAIN BUS: 200 AMP
NEUTRAL: F/N
MAIN: M.L.O.
LOCATION: WALL

K/VOLTS	POLE	TRIP	CONDUIT	WIRE	REMARKS	CKT. NO.	CKT. NO.	REMARKS	WIRE	CONDUIT	TRIP	POLE	K/VOLTS	AMPS.
7.0	1	60	3/4"	#6	AHU	1	2	RANGE	#8	3/4"	40	2	6.0	
1.0	1	20	1/2"	#12	LIGHTS/RECEPTACLES	5	6	APPLIANCES	#12	1/2"	20	1	1.0	
1.0	1	20	1/2"	#12	LIGHTS/RECEPTACLES	7	8	APPLIANCES	#12	1/2"	20	1	1.0	
1.0	1	20	1/2"	#12	LIGHTS/RECEPTACLES	9	10	REFRIGERATOR	#12	1/2"	20	1	1.2	
1.0	1	20	1/2"	#12	LIGHTS/RECEPTACLES	11	12	LIGHTS/RECEPTACLES	#12	1/2"	20	1	1.0	
8.0	2	40	3/4"	#10	E.W.H.	13	14	DRYER	#8	3/4"	30	2	4.5	
5.0	2	40	3/4"	#8	CU	15	16	GF	#12	1/2"	20	1	1.5	
1.0	1	20	1/2"	#12	TERRACE LIGHTS	17	18	GF	#12	1/2"	20	1	1.5	
1.0	1	20	1/2"	#12	TERRACE LIGHTS	19	20	MICROWAVE	#12	1/2"	20	1	1.5	
1.0	1	20	1/2"	#12	TERRACE LIGHTS	21	22	WASHER	#12	1/2"	20	1	1.5	
1.0	1	20	1/2"	#12	TERRACE LIGHTS	23	24	TERRACE RECEPTACLES	#12	1/2"	20	1	1.5	
1.0	1	20	1/2"	#12	TERRACE LIGHTS	25	26	TERRACE RECEPTACLES	#12	1/2"	20	1	1.5	
1.0	1	20	1/2"	#12	TERRACE LIGHTS	27	28	SPACE						
1.0	1	20	1/2"	#12	SPACE	29	30	SPACE						
													22.2	

TOTAL CONNECTED LOAD: 65.7KVA
TOTAL CONNECTED LOAD WITHOUT CU: 48.9KVA
TOTAL CONNECTED AMPS: 166 AMPS

TYPE: EXISTING
SERVICE: 36_4W
VOLTAGE: 120/208V.
MOUNTING: SUBFACE

TO BE LEGALIZED PANEL SUB "B"
10 KAIC
NEMA 1

MAIN BUS: F/N
NEUTRAL: F/N
MAIN: M.L.O.
LOCATION: WALL

K/VOLTS	POLE	TRIP	CONDUIT	WIRE	REMARKS	CKT. NO.	CKT. NO.	REMARKS	WIRE	CONDUIT	TRIP	POLE	K/VOLTS	AMPS.
2.0	1	20	1/2"	#12	PIZZA OVEN	1L	2L	GARBAGE DISPOSAL	#12	1/2"	20	1	1.5	
2.0	1	20	1/2"	#12	ICE MAKER	1R	2R	WATER HEATER	#12	1/2"	20	1	3.0	
2.0	1	20	1/2"	#12	RECEPTACLE/LIGHTING	3L	4L	BURNER	#12	1/2"	20	1	1.5	
2.0	1	20	1/2"	#12	MICROWAVE	3R	4R	REFRIGERATOR	#12	1/2"	20	1	1.5	
					SPACE	5	6	SPACE						
					SPACE	7	8	SPACE						
													7.5	

ELECTRICAL LEGEND AND NOTES

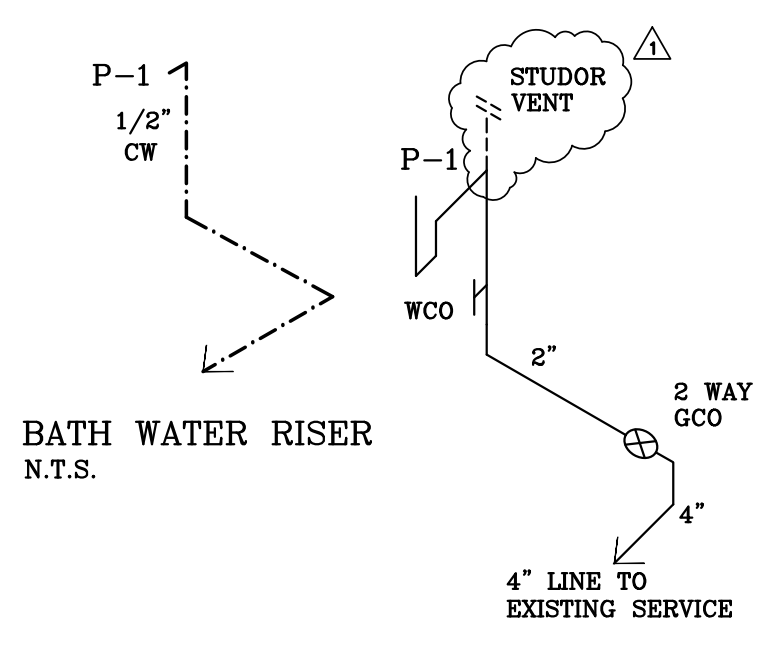

PLUMBING FIXTURE SCHEDULE FIRST FLOOR
UNLESS OTHERWISE NOTED.

MKT	FIXTURE	SIZE	VENT	WATER	DESCRIPTION	SLOPE
P-1	SHK	2"	1/2"	1/2"		1/4" FT.

2 POWER PLAN

PLUMBING GENERAL NOTES & SPECIFICATIONS.

- SCOPE OF WORK:
THE WORK SHALL INCLUDE ALL PLUMBING SHOWN ON THE DRAWINGS, SPECIFIED HEREIN AND OR AS NEEDED FOR A COMPLETE SYSTEM, INCLUDED BUT NOT NECESSARILY LIMITED TO THE FOLLOWING:
1. DOMESTIC COLD AND HOT WATER PIPING SYSTEMS.
2. SANITARY DRAIN AND VENT SYSTEMS.
3. PLUMBING FIXTURES AND TRIM.
4. AIR CONDITIONING CONDENSATE DRAIN SYSTEM.
5. PRESSURE AND TEMPERATURE RELIEF FROM WATER HEATER.
6. PIPING INSULATION.
7. SUPPORTS AND HANGERS.
8. ALL PLUMBING WORK SHALL BE PERFORMED IN ACCORDANCE WITH THE FLORIDA BUILDING CODE 2017 6th EDITION, CHAPTER 46 AND LOCAL ORDINANCES AND IN COMPLIANCE WITH THE FLORIDA ENERGY EFFICIENCY CODE FOR BUILDING CONSTRUCTION AND "HRS" REGULATION, IN THE EVENT OF CONFLICT BETWEEN ANY CODE OR REGULATIONS, THE MORE STRINGENT REQUIREMENT WILL GOVERN.
- CONTRACTOR SHALL VERIFY AT SITE THE LOCATION, ELEVATION AND SIZE OF ALL EXISTING LINES FOR CONNECTION BEFORE ANY INSTALLATION OF ANY PIPING.
- ALL FIXTURES SHALL BE PROTECTED AGAINST WATER HAMMER WITH AIR CHAMBERS OF SHOCK ABSORBERS AS INDICATED ON PLANS.
- PLUMBING FIXTURE SHALL BE CONSTRUCTED WITH APPROVED MATERIALS, SHALL HAVE SMOOTH INTERIORS SURFACES AND SHALL BE FREE FROM DEFECTS AND CONGEALED FOLLING SURFACES. ALL FIXTURE TRIM TO BE CHROME PLATED. FIXTURES TO BE PROVIDED WITH SUPPORTS, HANGERS, ETC.
- SANITARY SEWER LINES TO SLOPE 1/8" PER FOOT ON 2" LINES AND 1/4" PER FOOT ON 3" LINES.
- VENT LINES TO EXTEND MIN. OF 9" ABOVE ROOF AND FLASH WITH LEAD.
- WATER PIPE BELOW GROUND TO BE COPPER TYPE "K", ABOVE GROUND TO BE TYPE "L".
- PIPING INSTALLATION:
A. SUPPORT ALL PIPES FROM SOUND PORTION OF STRUCTURE AND AT PROPER INTERVALS ACCORDING TO CODE.
B. SMOOTH SLEEVES FOR ALL PIPING THROUGH FOUNDATIONS, SLABS, AND MASONRY WALLS. CAULK OPENINGS BETWEEN PIPES AND SLEEVES.
C. WHERE EXPOSED PIPES PASS THROUGH FLOORS, WALLS OR CEILINGS, PROVIDE ESCUTCHEONS. FIRMLY SECURE TO THE PIPES OF SUFFICIENT OUTSIDE DIAMETER TO COVER THE SLEEVED OPENINGS FOR THE PIPES. PROVIDE CHROMIUM PLATED ESCUTCHEONS IN BATHROOMS.
D. WHERE PIPES PASS THROUGH FIRE RATED FLOORS, WALLS OR CEILINGS, PROVIDE FIRESTOPS OR FIRE BARRIER PENETRATION SEALING. SYSTEMS SHALL BE U.L. LISTED.
- INSPECTION AND TESTS:
CONTRACTOR SHALL BE RESPONSIBLE TO ASK FOR INSPECTION TO THE AUTHORITIES HAVING JURISDICTION AS THE WORK PROGRESSES. ALL SYSTEMS SHALL BE TESTED BY CODE AND/OR LOCAL REGULATIONS. THE ENTIRE DOMESTIC WATER DISTRIBUTION SYSTEM SHALL BE STERILIZED FOLLOWING CODE PROCEDURES. AFTER STERILIZATION, THE SYSTEM SHALL BE FLUSHED WITH CLEAN WATER UNTIL SAFE TO BE CONSUMED.
- PLUMBING CONTRACTOR IS RESPONSIBLE FOR PERFORMING THE FOLLOWING TESTS IN THE PRESENCE OF AN OWNER REPRESENTATIVE:
A. ALL WATER PIPING SHALL BE SUBJECT TO HYDROSTATIC PRESSURE TEST OF 100 PSIG FOR A PERIOD OF SUFFICIENT TIME TO EXAMINE ENTIRE SYSTEM BUT NOT LESS THAN ONE HOUR.
B. DRAINAGE PIPING: BEFORE INSTALLATION OF ANY DRAINS, THE DRAIN OF THE SYSTEM SHALL BE CAPPED AND ALL LINES FILLED WITH WATER TO HIGHEST POINT AND ALLOWED TO STAND UNTIL INSPECTION IS MADE.
C. PLUMBING CONTRACTOR SHALL CORRECT ALL DEFECTS DISCLOSED IN ABOVE TESTS.

- STERILIZE ALL WATER LINES WITH A MIXTURE OF TWO(2) POUNDS OF CHLORINATED LIME TO EACH 1,000 GALLONS OF WATER (50 PPM OF AVAILABLE CHLORINE). RETAIN MIXTURE IN PIPE 24 HOURS AND FLUSH THOROUGHLY WITH POTABLE WATER BEFORE PLACING IT IN SERVICE.
- COMPLETE SYSTEM, FIXTURES AND EQUIPMENT SHALL BE GIVEN AN IN SERVICE TEST AFTER COMPLETION OF INSTALLATION.
- PLUMBING CONTRACTOR SHALL FURNISH WRITTEN GUARANTEE THAT ALL PLUMBING WORK IS FREE FROM DEFECTS OF MATERIALS AND WORKMANSHIP FOR A PERIOD OF (1) YEAR FROM DATE OF FINAL ACCEPTANCE, AND THAT HE WILL, AT HIS EXPENSE, REPAIR AND REPLACE ALL WORK WHICH BECOMES DEFECTIVE DURING THE GUARANTEE PERIOD INCLUDING BUT NOT LIMITED TO NECESSARY DEMOLITION, PATCHING, RE-PAINTING AND RE-FINISHING.
- PLUMBING CONTRACTOR IS RESPONSIBLE FOR INCLUDING IN HIS BID THE COST FOR OBTAINING ALL NECESSARY PERMITS REQUIRED TO PERFORM THE SCOPE OF THE WORK AND THE INTENT OF THE CONSTRUCTION DOCUMENTS FROM ALL THE LOCAL AND STATE AUTHORITIES.
- CONDENSATE DRAIN FROM AIR CONDITIONING UNITS SHALL BE PVC SCHEDULE 40 PIPE AND FITTINGS. ALL HORIZONTAL RUN SHALL BE INSULATED WITH 1/2" THICK ARMAFLEX PIPE INSULATION OR EQUAL. SLIP PIPE INSULATION AND SEAT BUTT JOINTS.
- ALL PIPING MATERIALS SHALL BE NEW AND AS FOLLOWS:
A. SANITARY WASTE, VENT AND STORM DRAIN PIPING, UNDERGROUND AND ABOVE GROUND PIPING SHALL BE "PVC" PIPE AND FITTINGS SCHEDULE 40. MATERIAL SHALL COMPLY WITH ASTM-1754, TYPE "1".
B. DOMESTIC WATER ABOVE GROUND SHALL BE TYPE "K" COPPER PIPE WITH WROUGHT COPPER SOLDERED JOINT FITTINGS.
C. DOMESTIC WATER BELOW GROUND SHALL BE TYPE "L" COPPER PIPE WITH WROUGHT COPPER SOLDERED JOINT FITTINGS.
D. PLUMBING FIXTURES SHALL BE AMERICAN MANUFACTURED.
E. SOLDER ALLOY SHALL BE LEAD FREE.
F. PROVIDE DIELECTRIC FITTINGS FOR JOINING DISSIMILAR METALS.
G. MALEABLE IRON SCREWED FITTINGS, PIPE 2-1/2" AND LARGER SHALL BE SCH. 40A BLACK STEEL PIPE WITH BUTT WELD FITTINGS.
- INSULATION:
A. ALL HOT WATER PIPE SHALL BE INSULATED WITH 1/2" THICK FIBERGLASS MOLDED INSULATION WITH PRE-SIZE FACTORY APPLIED "TRU" JACKET OF GLASS CLOTH WITH LONGITUDINAL LAP AND BUTT JOINT STRIPS WITH SELF SEALING ADHESIVE.
B. INSULATION SHALL HAVE A MAXIMUM THERMAL CONDUCTIVITY OF 0.26 K FACTOR AT 75 DEG. F. MEAN TEMPERATURE. JACKET INSULATION AND ADHESIVE SHALL HAVE COMPOST FIRE AND SMOKE RATINGS AS PER ASTM E84-75. FINISHING JACKETS SHALL HAVE A MAXIMUM FLAME SPREAD OF 25.
C. HANGERS AND SUPPORTS:
A. PROVIDE ADJUSTABLE HANGERS, INSERTS, BRACKETS, ROLLS, CLAMPS AND SUPPLEMENTARY STEEL AS REQUIRED FOR PROPER SUPPORT OF PIPE LINES. PROVIDE HANGERS TO ALLOW FOR EXPANSIONS AND CONTRACTION OF PIPE LINES AND OF ADEQUATE SIZE TO PERMIT COVERING TO BE CONTINUOUSLY SUPPORTED BY EQUIPMENT. COORDINATE LOCATION OF HANGERS WITH LIGHT FIXTURES AND A/C DUCTS.
- EXISTING CONDITIONS:
PLUMBING CONTRACTOR, BY AND THROUGH SUBMISSION OF HIS BID, AGREES THAT HE SHALL BE HELD RESPONSIBLE FOR HAVING EXAMINED THE SITE AND LOCATION OF ALL PROPOSED WORK AND FOR HAVING SATISFIED HIMSELF FROM HIS OWN PERSONAL KNOWLEDGE AND EXPERIENCE OR PROFESSIONAL ADVICE AS TO THE CHARACTER AND LOCATION OF THE SITE, THE NATURE OF THE EXISTING CONDITIONS AND THE LOCATION OF EXISTING UTILITIES AND ANY OTHER CONDITIONS SURROUNDING AND AFFECTING THE WORK. ANY OBSTRUCTIONS, THE NATURE OF EXISTING CONSTRUCTION AND ALL OTHER PHYSICAL CHARACTERISTICS OF THE JOB IN ORDER THAT HE MAY INCLUDE IN THE PRICES WHICH HE BIDS, ALL COSTS PERTAINING TO THE WORK AND THEREBY PROVIDE FOR A SATISFACTORY COMPLETION OF THE WORK.