



CITY OF FORT LAUDERDALE

COMMUNITY REDEVELOPMENT AGENCY

Memorandum

Memorandum No: 22-002

Date: May 3, 2022

To: Honorable CRA Chairman and Board of Commissioners

From: Christopher J. Lagerbloom, Executive Director

Re: Central City Redevelopment Area Streetlights Installation Project (**Commission Districts 2 and 3**)

The Community Redevelopment Agency (CRA) plans to install streetlights at several dead-end streets within the Central City Area. The work will cost the CRA a total of \$14,890.05. The City's electricity cost will be \$203.80 per month. Staff is seeking approval from the City for the monthly electricity cost.

At the January 12, 2022, and February 2, 2022, Central City Redevelopment Advisory Board (CCRAB) meetings, Advisory Board members discussed options for improving the aesthetics and safety of Sunrise Boulevard within the Central City CRA Area. Members expressed concerns with vagrancy and blighted conditions of several permanently closed side-streets which may be exacerbated by lack of adequate lighting (Attachment 1).

The following are areas of consideration:

- 1) NW 7th Terrace
- 2) NW 6th Avenue
- 3) NW 5th Avenue
- 4) NW 4th Avenue
- 5) NW 3rd Avenue
- 6) NW 2nd Avenue
- 7) NE 5th Avenue
- 8) NE 5th Terrace (North)
- 9) NE 5th Terrace (South)

At the April 6, 2022 CCRAB meeting, staff presented the Florida Power & Light (FPL) cost estimates to install streetlights at eight of the nine permanent street closures, and monthly electricity cost. The CCRAB unanimously supported funding for the streetlight installation for the total amount of \$12,408.38, in addition to a 20% contingency budget, for a grand total of \$14,890.05 (Attachment 2 and 3).

The City will incur a monthly electricity cost of \$203.80. Should the City agree to the monthly electricity cost of operating the streetlights, then the CRA will use current operation funds in the total amount of \$14,890.04 to cover the installation and a 20% contingency budget. The FPL price estimate is valid for six months and expires in September 2022.

Consistency with the Central City Community Redevelopment Plan

Section V.A. titled "Redevelopment Strategies -Purpose", provides that CRA undertake projects relating to infrastructure and neighborhood improvements that could include sidewalks, lighting, landscaping, and open space.

For more information, please contact Clarence Woods, CRA Manager, Communication Redevelopment Agency, at (954) 828-4519 or cwoods@fortlauderdale.gov.

Attachments:

- Attachment 1: January 12, 2022; February 6, 2022 CCRAB Approved Minutes
 - Attachment 2: April 6, 2022 CCRAB Draft Minutes
 - Attachment 3: FPL Preliminary Design Installation & Energy Cost Estimates
- c: Tarlesha Smith, Esq., Assistant City Manager
Greg Chavarria, Assistant City Manager
Alain Boileau, City Attorney
David Solomon, City Clerk
Patrick Reilly, Interim City Auditor
Phil Thornburg, Parks & Recreation Director
Corey Callier, Parks & Recreation Facilities Manager
Department Directors
CMO Managers



CITY OF FORT LAUDERDALE

APPROVED
RESCHEDULED REGULAR MEETING MINUTES
CITY OF FORT LAUDERDALE
CENTRAL CITY REDEVELOPMENT ADVISORY BOARD
WEDNESDAY, JANUARY 12, 2022 – 3:30 PM
CITY HALL - 8th FLOOR CONFERENCE ROOM
FORT LAUDERDALE, FL 33301

Board Members	Present/Absent	Cumulative Attendance	
		September 2021-August 2022	
		Present	Absent
Ray Thrower, Chair	P	4	1
Robert Ayen	P	4	1
Luis Castillo-Olivera	P	5	0
Adam Gellar	A	2	3
Charlene Gunn	P	5	0
Shane Jordan	P	4	1
Christina Robinson	P	2	2
Dennis Ulmer, Vice Chair	P	5	0
Moshe Yehoshoua	P	5	0

At this time, there are 9 appointed members to the Board; therefore, 5 constitute a quorum.

Staff:

Cija Omengebar, CRA Planner/Liaison
Clarence Woods, CRA Manager
Mark Alvarez, consultant, The Corradino Group
Carla Blair, Prototype Inc. Recording Secretary

I. Pledge of Allegiance

The Board recited the Pledge of Allegiance.

II. Call to Order & Determination of Quorum

Chair Castillo-Olivera called the meeting to order at 3:32 p.m. and Roll was called, and it was noted that a quorum was present.

III. Approval of Minutes

- Regular Meeting December 1, 2021

Motion made by Mr. Thrower, seconded by Mr. Ayen, to approve the December 1, 2021 minutes. In a voice vote, motion passed 8-0.

Motion made by Ms. Gunn, seconded by Mr. Ayen, to hear Item V before Item IV, since the presenter for Item IV had not arrived. In a voice vote, motion passed 8-0.

IV. Program and Project Status Update

- Rezoning Project – increase of scope

Mr. Woods recalled Mayor Trantalis had asked how much the additional analysis would cost and how long it would take. The City Attorney had opined that the additional work was new work and should be put out to bid. They were now waiting to see if this consultant would be permitted to bid. Mr. Castillo-Olivera noted they had now wasted eight months it would have taken for the project.

Mr. Castillo-Olivera recalled the prior contractor had been told that one priority in South Middle River was to improve this area because it was the most depressed area in the entire neighborhood. Mr. Woods stated they now understood the issues and what the remedy was but there were procurement technicalities to iron out.

Mark Alvarez, consultant, The Corradino Group, acknowledged the northwest quadrant was the most blighted area and said the zoning must be changed from RD-15 to allow two-family homes. Advisory board members and developers had indicated this was not enough: they needed to offer more. The issue was the City's Comprehensive Plan, which they could not exceed. The project had then been amended to change the Comprehensive Plan as well, which must be submitted to the County and State. Then there was the issue of procurement regarding adding this to the existing project or re-bidding.

Mr. Woods stated his biggest concern was whether the consultants would be able to respond to the new solicitation, because he felt there were economies of scale if they continued.

Chair Thrower said several years ago, they had decided on a smaller request for the peninsula because they did not want to spend the additional time and money for the land use amendment. They had been concentrating on getting Sunrise rezoned where the lots were shallow. Opinions had changed, and people wanted the whole package because NW 8th Avenue was so blighted. He asked when the procurement issue would be resolved and Mr. Woods stated he was working on it now. He thought the new bid would take two to three months.

Mr. Alvarez said the results of a study must be presented to the City Commission to change the zoning via ordinance, but he felt the City Commission would not do that, because of the bid to amend the Comprehensive Plan. Ms. Robinson thought that as time went on, this could be less desirable if the housing market declined. She said people in the neighborhood could also see the changes happening. She stated her area, on NW

3rd was significantly better than it was four years ago when she purchased her home there. Ms. Robinson said the time to make the changes was now.

- Incentive Programs

Ms. Omengabar said they now had approximately \$1 million. The Lofts project may apply for additional funding and the church was considering a food hall for which she thought they may apply for funding.

V. Nomination and Selection of Chair Position

Ms. Gunn nominated Mr. Thrower for Chair, and in a voice vote, Mr. Thrower was elected unanimously.

Ms. Gunn nominated Mr. Ulmer for Vice Chair, seconded by Mr. Thrower. In a voice vote, Mr. Ulmer was elected unanimously.

VI. Communication to City Commission

None

VII. Old/New Business

- February Agenda Items Suggestions

Chair Thrower thought the homeless problem on Sunrise had tripled in the last few months. He pointed out that there were road closures that backed up to Sunrise and those roads were very dark. Chair Thrower wanted to consider using CRA funds to add lighting on those streets and clean the sidewalks, which he thought they were doing in the Northwest CRA. Mr. Woods said the Northwest did not use CRA funds for that, it was a City “Clean Team” program. Chair Thrower asked specifically about solar pedestrian lighting, like that used in the Northwest area.

Ms. Robinson asked how they could fund additional lighting and Mr. Woods explained they needed to consider this in a holistic way, along with streetscape. He suggested putting this discussion on the next agenda. Ms. Omengabar said they could also conduct a workshop in the future. She agreed to do additional research regarding lights and street closures.

Mr. Ulmer requested someone from the Homeless Outreach program and Public Works attend their next meeting to discuss homelessness and the Clean Team. The Board could ask about expanding these programs in the CRA.

Board members discussed open Board positions now that Ms. Gunn and Mr. Castillo-Olivera were leaving.

VIII. Adjournment

There being no further business, the meeting was adjourned at 5:03 p.m.

The next meeting will be held on February 2, 2022.

[Minutes written by J. Opperlee, Prototype, Inc.]



CITY OF FORT LAUDERDALE

APPROVED
RESCHEDULED REGULAR MEETING MINUTES
CITY OF FORT LAUDERDALE
CENTRAL CITY REDEVELOPMENT ADVISORY BOARD
WEDNESDAY, FEBRUARY 2, 2022 – 3:30 PM
CITY HALL - 8th FLOOR CONFERENCE ROOM
FORT LAUDERDALE, FL 33301

Board Members	Present/Absent	Cumulative Attendance	
		September 2021-August 2022	
		Present	Absent
Ray Thrower, Chair	P	5	1
Robert Ayen	A	4	2
Luis Castillo-Olivera	A	5	1
Adam Gellar	A	2	4
Charlene Gunn	A	5	1
Shane Jordan	A	4	2
Christina Robinson	P	3	2
Dennis Ulmer, Vice Chair	P	6	0
Moshe Yehoshoua [until 4:31]	P	6	0

At this time, there are 9 appointed members to the Board; therefore, 5 constitute a quorum.

Staff:

Cija Omengebar, CRA Planner/Liaison
Clarence Woods, CRA Manager
Corey Callier, Facilities Manager
Jamie Opperlee, Prototype Inc. Recording Secretary

I. Pledge of Allegiance

The Board recited the Pledge of Allegiance.

II. Call to Order & Determination of Quorum

Chair Thrower called the meeting to order at 3:43 p.m. and Roll was called, and it was noted that a quorum was **not** present.

III. Introduction of Board Members and Staff

Ordinance No. C-12-26 Advisory Board
Resolution No. 13-20 Central City CRA

Board members and staff introduced themselves.

Ms. Omengebar discussed Board membership requirements.

Mr. Woods stated the Florida Legislature had determined that all Florida CRAs would terminate in 2039.

IV. Approval of Minutes

- Rescheduled Regular Meeting January 12, 2022

The Board did not have a quorum, so approval of the minutes was deferred to the next meeting.

V. Exploring Lighting Options Discussion

Board members viewed photos of closed roads. Chair Thrower noted most of the photographs looked better than the roads usually do. Ms. Omengabar said the City's Neighborhood Support Division worked with neighborhood associations to clean up the areas and the City removed the trash.

Ms. Robinson said last October she had visited every closed road and reported all issues to the City. She had visited again just prior to the meeting and said they all looked pretty good.

Mr. Callier said the City's Clean Team cleared the streets of debris, but they did not clean up the closed roads.

Chair Thrower asked Mr. Callier about lighting for the closed roads. Mr. Callier stated solar would not be appropriate but the City could consider pedestrian or street lighting. He noted that street lighting illuminated a much larger area than pedestrian lighting. He explained that in some places, there may not be enough room in the right-of-way to install a streetlight, but they could consider getting an easement from an adjacent property owner. Mr. Callier stated once they received a request for a new light, they canvassed neighbors within 100 feet to see if there were any objections.

Mr. Callier said FPL could provide an estimate of costs based on the type of fixture. He described how the FPL lighting program had changed over time. He informed the Board that there was no solar option in the streetlight master plan. He stated the cost to replace the batteries for solar lights was "astronomical."

Ms. Robinson noted the amount of foliage in most of the closed areas and suggested cutting back the trees to improve light.

Mr. Woods pointed out they did not have a large budget and lighting entailed immediate costs, plus maintenance costs going forward. Once the CRA sunsetted, he questioned whether the City Commission would agree to pay for maintenance out of the general fund.

Ms. Robinson stated NE 5th Terrace needed to be cleaned up. Mr. Yehoshoua suggested thinning out the lower part of the tree only, and noted that keeping the tree made the closure more visible for motorists.

Chair Thrower said one drawback to closed roads was that the lack of traffic led to undesirable people hanging out at the closures.

Ms. Robinson stated she was on the Sunrise Boulevard Action Committee and she would discuss the code issues in this area at their meeting the following day. She suggested the South Middle River Civic Association [SMRCA] use some of their funds to trim trees.

Mr. Yehoshoua left the meeting at 4:31.

Mr. Callier pointed out that the closures were made with the agreement that the neighborhood associations would maintain the areas. Ms. Omengabar stated there was an agreement between Neighborhood Support and HOAs that HOAs would clean the areas and the City would pick up the debris, but there was no agreement with SMRCA.

Chair Thrower said he had been told that the closings along Sunrise Boulevard had been implemented through a Broward Beautiful grant and SMRCA agreed to maintain them.

Mr. Callier explained this was how it worked with neighborhood monuments and guardhouses as well: after they were installed, the associations were supposed to maintain them.

Mr. Woods said there were three paths to pursue: consult with FPL regarding streetlights, maintenance and power for the nine road closures; determine who was responsible for trimming and cleaning/maintenance; address the criminal or homeless element who sometimes inhabited the areas.

Ms. Robinson asked about power washing and cleaning businesses on Sunrise Boulevard. Mr. Woods stated this could be part of a façade improvement program for commercial businesses.

Mr. Callier said one challenge would be where to locate a streetlight in a road closure. It depended on right-of-way. If the Board wanted streetlights, he suggested positioning them away from foliage, closer to Sunrise Boulevard.

VI. Program and Project Status Update

- Rezoning Project

Mr. Woods stated they would have the consultant finish the existing and current zoning. He acknowledged that this price would not include everything everyone wanted. The City Manager had asked Planning and Zoning to do a Land Use Plan Amendment in-house to save money and time.

Ms. Omengebar agreed to update the Board in March regarding the report completion date. Chair Thrower was looking forward to the report. He acknowledged it did not give them what some people wanted for the northwest quadrant, but it would provide a lot of what they wanted for the rest of the CRA.

- NE 4th Avenue Streetscape Project

Ms. Omengebar said they were in the FDOT permitting phase.

- Incentive Programs
 - Program and Application

Ms. Omengebar had included a copy of the budget for Board members. She said she had heard from someone who was serious about applying for a wedding venue at 603 NE 13th Street.

Ms. Omengebar said her next focus, apart from the rezoning, was to come up with innovative ideas to reach out to property owners.

- FY 2022 Area Budget

Ms. Omengebar reported they had \$500,000 plus an additional \$516,000 left from 2021.

Ms. Omengebar suggested they could bring back the design standards ideas to maintain the character of Central City.

Regarding CRA design standards, Ms. Robinson said the goal of the Sunrise Boulevard Action Committee was to create a Sunrise Boulevard business alliance and the CCRAB should coordinate with them.

VII. Communication to City Commission

None

VIII. Old/New Business

- FDOT Projects in the Area
 1. New – Intersection and Safety Improvement

Ms. Omengebar said the project at the intersection of Sunrise Boulevard and 9th Avenue would start in summer 2022.

2. Done – Sunrise Blvd. Pedestrian Safety Enhancement Program

- Online Resources – Central City CRA

Chair Thrower pointed out that the online resources were great. He asked Ms. Robinson to show this to business owners.

- March Agenda Items Suggestions

1. Discussion on City Homeless Initiative

Ms. Omengebar confirmed that someone from the Police Department and Neighbor Support would attend the Board's March meeting.

IX. Adjournment

There being no further business, the meeting was adjourned at 5:10 p.m.

The next meeting will be held on March 2, 2022.

[Minutes written by J. Opperlee, Prototype, Inc.]

NW 7th Terr



NW 6th Ave



NW 5th Ave

CRA Memorandum No. 22-002
Attachment 1



NW 4th Ave



NW 3rd Ave



NW 2nd Ave

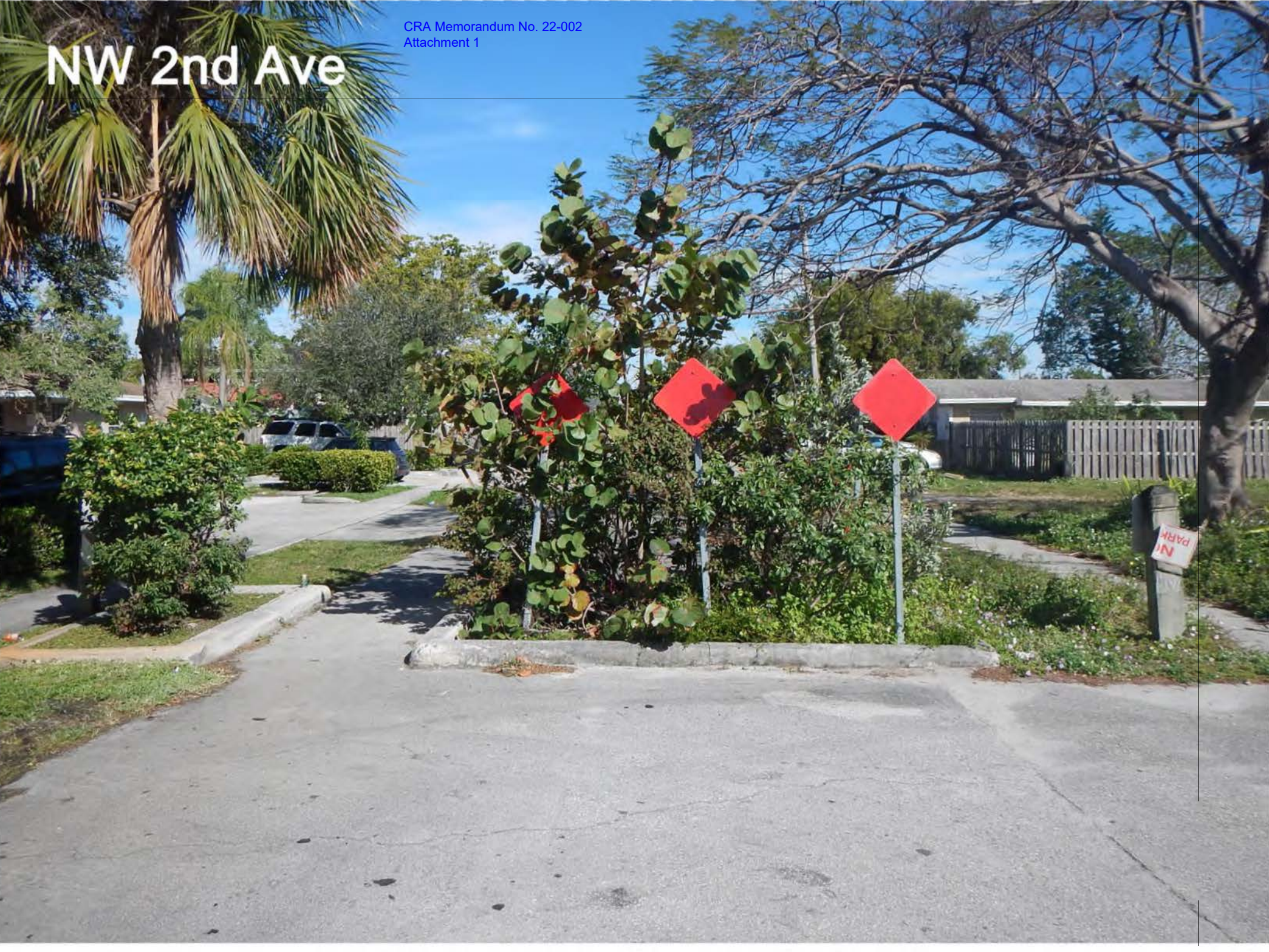

NE 5th Ave

CRA Memorandum No. 22-002
Attachment 1



NE 5th Terr (N)



NE 5th Terr (S)





CITY OF FORT LAUDERDALE

DRAFT
REGULAR MEETING MINUTES
CITY OF FORT LAUDERDALE
CENTRAL CITY REDEVELOPMENT ADVISORY BOARD
WEDNESDAY, APRIL 6, 2022 – 3:30 PM
CITY HALL - 8th FLOOR CONFERENCE ROOM
FORT LAUDERDALE, FL 33301

Board Members	Present/Absent	Cumulative Attendance	
		September 2021-August 2022	
		Present	Absent
Ray Thrower, Chair	P	6	1
Justin Greenbaum	P	1	0
Shane Jordan	P	5	2
Christina Robinson	P	4	2
Dennis Ulmer, Vice Chair	P	7	0

At this time, there are 5 appointed members to the Board; therefore, 3 constitute a quorum.

Staff:

Cija Omengebar, CRA Planner/Liaison
Clarence Woods, CRA Manager
Officer Brian Blount
Jamie Opperlee, Prototype Inc. Recording Secretary

Communication to the City Commission:

Motion made by Mr. Ulmer, seconded by Mr. Jordan to recommend the City have a public service campaign to discourage people from giving donations to panhandlers. Motion passed unanimously.

I. Pledge of Allegiance

The Board recited the Pledge of Allegiance.

II. Call to Order & Determination of Quorum

Chair Thrower called the meeting to order at 3:32 p.m. and Roll was called, and it was noted that a quorum was present.

III. Introduction of Board Members and Staff

Board members and guests introduced themselves.

IV. Approval of Minutes

- Rescheduled Regular Meeting January 12, 2022
- Regular Meeting February 2, 2022

Chair Thrower noted a correction to the January 12, 2022 minutes.

Motion by Mr. Ulmer, seconded by Mr. Jordan to approve the minutes of the January 12, 2022 meeting as amended. Motion passed unanimously.

Motion by Mr. Ulmer, seconded by Mr. Jordan to approve the minutes of the February 2, 2022 meeting. Motion passed unanimously.

V. Homeless Initiative Discussion

Officer Brian Blount, Homeless Outreach Team

Officer Blount described outreach efforts in coordination with the City's partners, to help the homeless transition into getting off the streets. He remarked that many people refused services and chose to remain homeless. He said Community Court was held every Wednesday to allow people to gain access to services if they wished. Officer Blount said they also visited HOPE South Florida once per week to offer services. He noted the lack of shelter beds and services available and said Covid Protocols were still in place in the shelters.

Officer Blount stated they were overwhelmed in Fort Lauderdale. He said when a homeless person was released from the main jail in Fort Lauderdale, they often stayed in the City. In January, they estimated 2,500 homeless in the County and 750 in Fort Lauderdale.

Officer Blount said people must stop giving money to panhandlers, which would hopefully encourage them to seek the services available. He said they were starting initiatives to get this message out to the public.

Officer Blount said beds were distributed through the County Task Force for Ending Homelessness. The biggest issues for providing services were low staffing and lack of budget. He said Homelessness was often at the bottom of the list for City and County budgets.

Officer Blount described the Community Court process and how people were tracked.

Officer Blount said during Covid last year, the City had used Covid and FEMA funds to house the homeless in a hotel. The City had investigated buying a hotel to house people and offer the services, but the problem was no one wanted such a residence in their neighborhood.

Chair Thrower wanted to send a Communication to the City Commission that it should make more of an effort to tell the public not to give money to homeless people.

Officer Blount said per the annual surveys, the number of homeless in Fort Lauderdale had remained fairly consistent.

Ms. Robinson asked how the Board could partner with HOPE South Florida. She suggested creating an area on their property with benches or chairs and tables with shade to allow them to eat. Or they could move the feeding area onto the parking lot on the other side of Andrews, away from the residential area, because they did not need all that parking. Officer Blount felt that would be a good start. Ms. Robinson asked if Officer Blount would suggest street lighting the Board could fund to help with the homeless situation. Office Blount said every business came thought the Crime Prevention Through Environmental Design, which advised them where lighting would serve as a deterrent.

Ms. Robinson asked about the closed streets and Officer Blount said the streets had been closed during the crack epidemic of the 1980s and 1990s to prevent people from the western suburbs from cruising side streets in search of drugs. He stated these closures were preventing crime.

Chair Thrower said he lived on a street that was not blocked and he felt safer there. He thought they should consider reopening some of the closed streets.

Mr. Ulmer pointed out that the County controlled homeless funds, so they needed to remind the County that it was not doing its job.

VI. Discussion and Recommendation

- **Street Closure FPL Lighting Installation Cost Estimates**

Ms. Omengebar had provided Board members with the cost estimates from FPL for the lighting: \$12,000 for eight light poles. The City would cover the energy costs of \$203 per month.

Mr. Greenbaum asked how much money they could allocate to something that was not an incentive program. Mr. Woods said operational/administrative costs should be no more than 20% of the total budget. Ms. Omengebar said the Board would vote on the budget in May or June.

Mr. Woods said they had been concentrating on completing the rezoning project. In the past, they had discussed starting conversations about other projects they could do, such as creating design standards and guidelines for facades but the previous Board had wanted to concentrate on the rezoning.

Mr. Greenbaum wanted to include an agenda item to discuss a residential improvement incentive program.

Motion made by Mr. Greenbaum, seconded by Mr. Jordan, to include the FPL street lights in the next capital project budget, and to include a contingency of up to 20%. Motion passed unanimously.

VII. Program and Project Status Update

- Rezoning Project

Ms. Omengabar said they were finishing the scope of the proposal and would then solicit firms to complete the Land Use Plan Amendment. The proposal was projected to be done by the end of the year.

- NE 4th Avenue Streetscape Project

Ms. Omengabar said they were still in the FDOT approval process.

- Incentive Programs

Ms. Omengabar had received a draft application for a tenant at 603 NE 13th Street and hoped to present it to the Board in May.

VIII. Communication to City Commission

Board members discussed the City discouraging people from giving money to panhandlers.

Mr. Greenbaum suggested signs in the downtown area. Mr. Jordan suggested using social media. Mr. Ulmer said they should suggest a public service campaign and let the City decide how.

Motion made by Mr. Ulmer, seconded by Mr. Jordan to send a communication to the City Commission to recommend the City have a public service campaign to discourage people from giving donations to panhandlers. Motion passed unanimously.

IX. Old/New Business

May Agenda Items Suggestions

1. Discuss instituting a residential façade program.
2. Review the LauderTrail plan so the Board could make suggestions to improve it in their area.
3. Review commuter rail options that would affect the CRA so the Board could provide input.
4. Discuss what they could do to partner with HOPE South Florida.

X. Adjournment

There being no further business, the meeting was adjourned at 5:15 p.m.

The next meeting will be held on May 4, 2022.

[Minutes written by J. Opperlee, Prototype, Inc.]

PAYMENT COUPON

/4115006400486800008005180027410920001240839

CITY OF FORT LAUDERDALE
100 N ANDREWS AVE
FORT LAUDERDALE FL 33301

Cust. No.: 6800008005 Bill No.: 1800274109	
Payment Due Upon Receipt	Amount Due This Bill \$ 12,408.39
Reference# D00011306599	

Your payment may be eligible to be paid online. Visit www.fpl.com/construction to learn more. You can also mail a check payable to FPL in USD to the FPL address listed below right. Please mail the top portion of the coupon with your check.

FPL
General Mail Facility
Miami FL 33188-0001

Please retain this portion for your records.

Florida Power & Light Company
Federal Tax Id.#: 59-0247775
Customer Name and Address

CITY OF FORT LAUDERDALE
100 N ANDREWS AVE
FORT LAUDERDALE FL 33301

Customer Number: 6800008005
Reference Number: D00011306599
Bill Number: 1800274109
Bill Date: 03/17/2022

CURRENT CHARGES AND CREDITS

Customer No: 6800008005 Bill No: 1800274109

Description	Amount
FPLES LGHT/715 W SUNRISE BLVD Reference# D00011306599	12,408.39
For Inquiries Contact: Marlon Barrios 7868630937	Total Amount Due \$12,408.39 Payment Due Upon Receipt

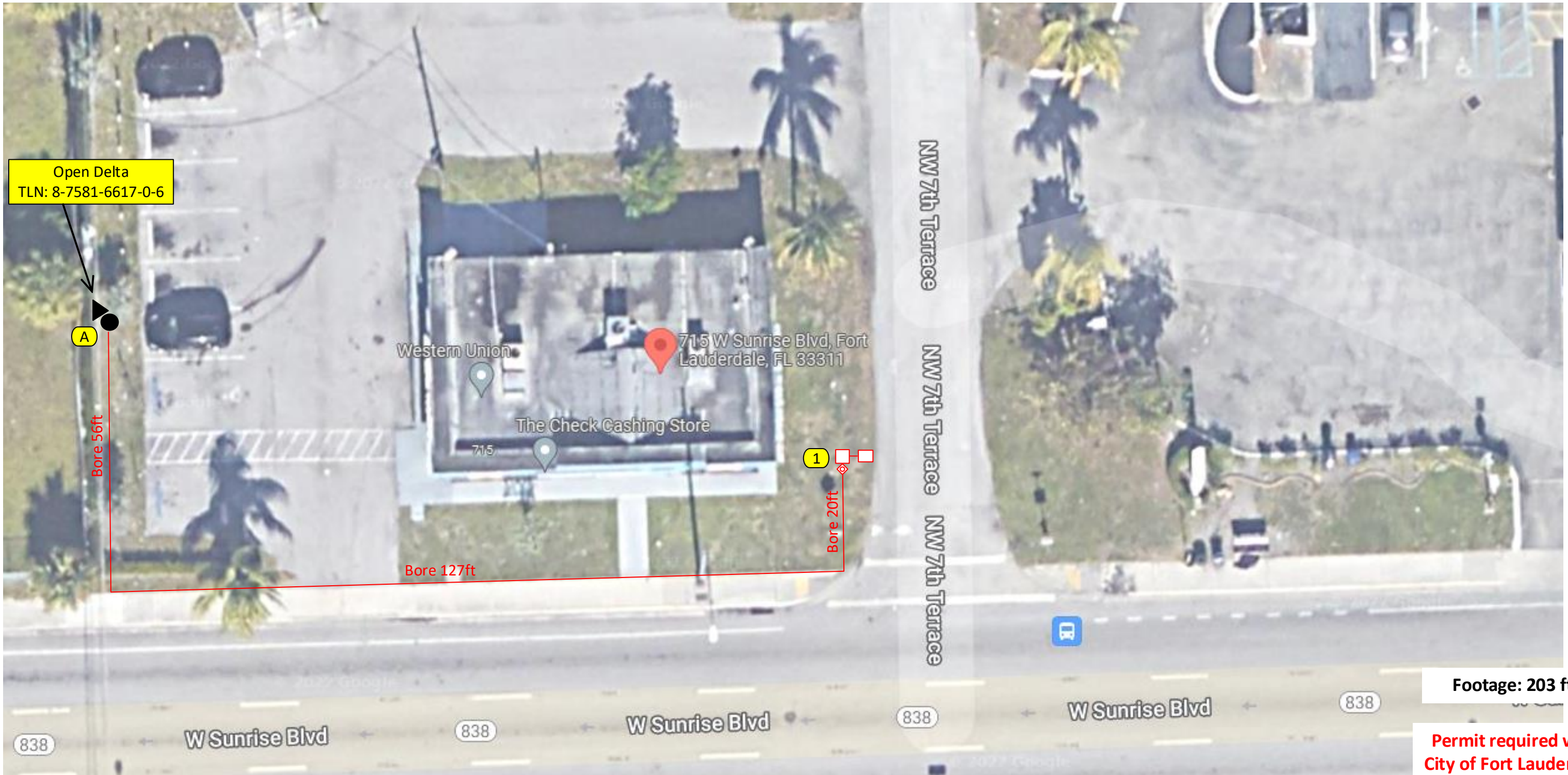

Footage: 203 ft.

Permit required with City of Fort Lauderdale

Construction Notes: (FPL contractor installing conduit)

- Loc. 1: Install 1 Roadway 5,000L 42W 3K LED with 6ft bracket on NEW 35' standard street light concrete pole.
- Loc. A: Install 2" riser on existing distribution wood pole.

FPL contractor to install 2" flex pipe with 24" minimum cover as shown in the drawing using directional bore. Cable to be used is #6 DPX. FPL contractor installing hand-holes and staking locations of the poles. Pole on this page to be installed in R/W in the back-end of the sidewalk.

- Customer responsible for any restoration required. All hand-holes to be 17" unless noted.

Sales Rep: Marlon Barrios

AS-BUILT CREW PRINT		ALL REQUIRED GROUND RODS HAVE BEEN DRIVEN & VERIFIED TO BE WITHIN FPL STANDARDS. VALUES ARE SHOWN AT ALL LOCATIONS.		JOB CERTIFIED COMPLETED AS SHOWN ON THIS AS-BUILT PRINT. MATERIAL CHANGES SHOWN IN RED.		AS-BUILT COPY	
FOREMAN'S SIG NATURE _____ DATE _____		FOREMAN'S SIG NATURE _____ DATE _____		SUPERVISOR'S SIG NATURE _____ DATE _____		INITIALS _____ CERT. DATE _____	
Easement? Yes <input type="checkbox"/> No <input checked="" type="checkbox"/>		Survey/Stake? Yes <input type="checkbox"/> No <input checked="" type="checkbox"/>		Work with SMO? Yes <input type="checkbox"/> No <input checked="" type="checkbox"/>		FPL City of Fort Lauderdale - New SL 1000 NE 16th PL 1 New light 1000 NE 16th PL, FORT LAUDERDALE, FL 33305	
Tree Work? Yes <input type="checkbox"/> No <input checked="" type="checkbox"/>		Designer/Stake? Yes <input type="checkbox"/> No <input checked="" type="checkbox"/>		CT/Special Mtr? Yes <input type="checkbox"/> No <input checked="" type="checkbox"/>			
PERMIT REQ'D	City <input checked="" type="checkbox"/> WMD	County Rd. <input type="checkbox"/> RR Xing	County Air <input type="checkbox"/> DR. Dist.	State Road <input type="checkbox"/> Transm.	FAA <input type="checkbox"/>	Designed by: Thais Garcia Date: 03/15/22 Drawn by: TG Check by: _____ Dwg No. 1 OF 8	
Requested Tel. Co. Set Poles? YES <input type="checkbox"/> NO <input checked="" type="checkbox"/>		Requested Tel. Co. Transfer? YES <input type="checkbox"/> NO <input checked="" type="checkbox"/>		Request CAVT Transfer? YES <input type="checkbox"/> NO <input checked="" type="checkbox"/>		Rural Location Sec. xx TWP. xx S, RGE. xx E. SCALE: N.T.S St. Lt MAP No. MAP# Pri Map No. xxxxxx TLM/LDS MODEL No. - Map Posting? YES <input checked="" type="checkbox"/> NO <input type="checkbox"/> Posted by: WR xxxxxxx M/A xx	
POLE LINE FEET 0'		DUCT BANK FT. 0'		POLE LINE FT. ON TRANSM. POLES 0'		TRENCH FT. 0'	



**Permit required with
City of Fort Lauderdale**

Construction Notes: (FPL contractor installing conduit)

- Loc. 2: Install 1 Roadway 5,000L 42W 3K LED with 6ft bracket on NEW 35' standard street light concrete pole.
- Loc. B: Install 2" riser on existing distribution wood pole.
- Loc. C: Install 24" hand-hole.

FPL contractor to install 2" flex pipe with 24" minimum cover as shown in the drawing using directional bore. Cable to be used is #6 DPX. FPL contractor installing hand-holes and staking locations of the poles. Pole on this page to be installed in R/W in the back-end of the sidewalk.

- Customer responsible for any restoration required. All hand-holes to be 17" unless noted.

Sales Rep: Marlon Barrios

AS-BUILT CREW PRINT		ALL REQUIRED GROUND RODS HAVE BEEN DRIVEN & VERIFIED TO BE WITHIN FPL'S STANDARDS. VALUES ARE SHOWN AT ALL LOG LOCATIONS.		JOB CERTIFIED COMPLETED AS SHOWN ON THIS AS-BUILT PRINT. MATERIAL CHANGES SHOWN IN RED.		AS-BUILT COPY	
FOREMAN'S SIG NATURE _____ DATE _____		FOREMAN'S SIG NATURE _____ DATE _____		SUPERVISOR'S SIG NATURE _____ DATE _____		INITIALS _____ CERT. DATE _____	
Easement? Yes <input type="checkbox"/> No <input checked="" type="checkbox"/>		Survey/Stake? Yes <input type="checkbox"/> No <input checked="" type="checkbox"/>		Work with SMO? Yes <input type="checkbox"/> No <input checked="" type="checkbox"/>		FPL City of Fort Lauderdale - New SL 1000 NE 16th PL 1 New light 1000 NE 16th PL, FORT LAUDERDALE, FL 33305	
Tree Work? Yes <input type="checkbox"/> No <input checked="" type="checkbox"/>		Designer/Stake? Yes <input type="checkbox"/> No <input checked="" type="checkbox"/>		CT/Special Mtr? Yes <input type="checkbox"/> No <input checked="" type="checkbox"/>			
PERMIT REQ'D City <input checked="" type="checkbox"/> County Rd. _____ County Air _____ State Road _____ FAA _____		WMD _____ RR Xing _____ DR. Dist. _____ Transm. _____		Tele. Attachment Per _____ Telephone Co. Job No. _____			
Requested Tel. Co. Set Poles? YES <input type="checkbox"/> NO <input checked="" type="checkbox"/>		Requested Tel. Co. Transfer? YES <input type="checkbox"/> NO <input checked="" type="checkbox"/>		Request CAVT Transfer? YES <input type="checkbox"/> NO <input checked="" type="checkbox"/>		Designed by: Thais Garcia Date: 03/15/22	
POLE LINE FEET 0'		DUCT BANK FT. 0'		POLE LINE FT. ON TRANSM. POLES 0'		TRENCH FT. 0'	
Rural Location Sec. _____ xx TWP. _____ xx S, RGE. _____ xx E.		SCALE: N.T.S.		St. Lt MAP No. _____ MAP# _____ Pri Map No. _____ xxxxxx		WR xxxxxxx M/A xx	
TLM/LDS MODEL No. -		Map Posting? YES <input checked="" type="checkbox"/> NO <input type="checkbox"/>		Posted by: _____			

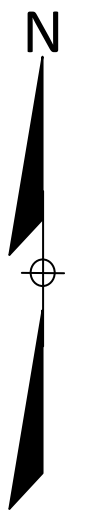

Bore 144ft

Bore 53ft

Footage: 197 ft.

**Permit required with
City of Fort Lauderdale**

Construction Notes: (FPL contractor installing conduit)

- Loc. 3: Install 1 Roadway 5,000L 42W 3K LED with 6ft bracket on NEW 35' standard street light concrete pole.
- FPL contractor to install 2" flex pipe with 24" minimum cover as shown in the drawing using directional bore. Cable to be used is #6 DPX. FPL contractor installing hand-holes and staking locations of the poles. Pole on this page to be installed in R/W in the back-end of the sidewalk.
- Customer responsible for any restoration required. All hand-holes to be 17" unless noted.

Sales Rep: Marlon Barrios

AS-BUILT CREW PRINT		ALL REQUIRED GROUND RODS HAVE BEEN DRIVEN & VERIFIED TO BE WITHIN FPL STANDARDS. VALUES ARE SHOWN AT ALL LOCATIONS.		JOB CERTIFIED COMPLETED AS SHOWN ON THIS AS-BUILT PRINT. MATERIAL CHANGES SHOWN IN RED.		AS-BUILT COPY	
FOREMAN'S SIGNATURE _____ DATE _____		FOREMAN'S SIGNATURE _____ DATE _____		SUPERVISOR'S SIGNATURE _____ DATE _____		INITIALS _____ CERT. DATE _____	
Easement? Yes <input type="checkbox"/> No <input checked="" type="checkbox"/>		Survey/Stake? Yes <input type="checkbox"/> No <input checked="" type="checkbox"/>		Work with SMO? Yes <input type="checkbox"/> No <input checked="" type="checkbox"/>		FPL City of Fort Lauderdale - New SL 1000 NE 16th PL 1 New light 1000 NE 16th PL, FORT LAUDERDALE, FL 33305	
Tree Work? Yes <input type="checkbox"/> No <input checked="" type="checkbox"/>		Designer/Stake? Yes <input type="checkbox"/> No <input checked="" type="checkbox"/>		CT/Special Mtr? Yes <input type="checkbox"/> No <input checked="" type="checkbox"/>			
PERMIT REQ'D	City <input checked="" type="checkbox"/> WMD	County Rd. <input type="checkbox"/> RR Xing	County Air <input type="checkbox"/> DR. Dist.	State Road <input type="checkbox"/> Transm.	FAA <input type="checkbox"/>	Designed by: Thais Garcia Date: 03/15/22	
Requested Tel. Co. Set Poles? YES <input type="checkbox"/> NO <input checked="" type="checkbox"/>		Requested Tel. Co. Transfer? YES <input type="checkbox"/> NO <input checked="" type="checkbox"/>		Request CAVT Transfer? YES <input type="checkbox"/> NO <input checked="" type="checkbox"/>		Drawn by: TG Check by: _____ Dwg No. 3 OF 8	
POLE LINE FEET 0'		DUCT BANK FT. 0'		Rural Location Sec. xx TWP. xx S, RGE. xx E.		SCALE: N.T.S. St. Lt MAP No. MAP# Pri Map No. xxxxxx	
POLE LINE FT. ON TRANSM. POLES 0'		TRENCH FT. 0'		TLM/LDS MODEL No. -		Map Posting? YES <input checked="" type="checkbox"/> NO <input type="checkbox"/> Posted by: WR xxxxxx M/A xx	



Footage: 413 ft.

**Permit required with
City of Fort Lauderdale**

Construction Notes: (FPL contractor installing conduit)

Loc. 4-5: Install 1 Roadway 5,000L 42W 3K LED with 6ft bracket on NEW 35' standard street light concrete pole.
Loc. D-E: Install 24" hand-hole

FPL contractor to install 2" flex pipe with 24" minimum cover as shown in the drawing using directional bore. Cable to be used is #6 DPX. FPL contractor installing hand-holes and staking locations of the poles. Pole on this page to be installed in R/W in the back-end of the sidewalk.

- Customer responsible for any restoration required. All hand-holes to be 17" unless noted.

Sales Rep: Marlon Barrios

AS-BUILT CREW PRINT		ALL REQUIRED GROUND RODS HAVE BEEN DRIVEN & VERIFIED TO BE WITH FPL STANDARDS. VALUES ARE SHOWN AT ALL LOGS/TONGS.		JOB CERTIFIED COMPLETED AS SHOWN ON THIS AS-BUILT PRINT. MATERIAL CHANGES SHOWN IN RED.		AS-BUILT COPY	
FOREMAN'S SIG NATURE _____ DATE _____		FOREMAN'S SIG NATURE _____ DATE _____		SUPERVISOR'S SIG NATURE _____ DATE _____		INITIALS _____ CERT. DATE _____	
Easement? Yes <input type="checkbox"/> No <input checked="" type="checkbox"/>		Survey/Stake? Yes <input type="checkbox"/> No <input checked="" type="checkbox"/>		Work with SMO? Yes <input type="checkbox"/> No <input checked="" type="checkbox"/>		FPL City of Fort Lauderdale - New SL 1000 NE 16th PL 1 New light 1000 NE 16th PL, FORT LAUDERDALE, FL 33305	
Tree Work? Yes <input type="checkbox"/> No <input checked="" type="checkbox"/>		Designer/Stake? Yes <input type="checkbox"/> No <input checked="" type="checkbox"/>		CT/Special Mtr? Yes <input type="checkbox"/> No <input checked="" type="checkbox"/>			
PERMIT REQ'D	City <input checked="" type="checkbox"/> WMD	County Rd. <input type="checkbox"/> RR Xing	County Air <input type="checkbox"/> DR. Dist.	State Road <input type="checkbox"/> Transm.	FAA <input type="checkbox"/>	Designed by: Thais Garcia Date: 03/15/22	
Requested Tel. Co. Set Poles? YES <input type="checkbox"/> NO <input checked="" type="checkbox"/>		Requested Tel. Co. Transfer? YES <input type="checkbox"/> NO <input checked="" type="checkbox"/>		Request CAVT Transfer? YES <input type="checkbox"/> NO <input checked="" type="checkbox"/>		Drawn by: TG Check by: _____ Dwg No. 4 OF 8	
POLE LINE FEET 0'		DUCT BANK FT. 0'		Rural Location Sec. xx TWP. xx S, RGE. xx E.		SCALE: N.T.S. St. Lt MAP No. MAP# Pri Map No. xxxxxx	
POLE LINE FT. ON TRANSM. POLES 0'		TRENCH FT. 0'		TLM/LDS MODEL No. -		Map Posting? YES <input checked="" type="checkbox"/> NO <input type="checkbox"/> Posted by: WR xxxxxx M/A xx	



**Permit required with
City of Fort Lauderdale**

Construction Notes: (FPL contractor installing conduit)

Loc. 6: Install 1 Roadway 5,000L 42W 3K LED with 6ft bracket on NEW 35' standard street light concrete pole.

FPL contractor to install 2" flex pipe with 24" minimum cover as shown in the drawing using directional bore. Cable to be used is #6 DPX. FPL contractor installing hand-holes and staking locations of the poles. Pole on this page to be installed in R/W in the back-end of the sidewalk.

- Customer responsible for any restoration required. All hand-holes to be 17" unless noted.

Sales Rep: Marlon Barrios

AS-BUILT CREW PRINT		ALL REQUIRED GROUND RODS HAVE BEEN DRIVEN & VERIFIED TO BE WITHIN FPL'S STANDARDS. VALUES ARE SHOWN AT ALL LOCATIONS.		JOB CERTIFIED COMPLETED AS SHOWN ON THIS AS-BUILT PRINT. MATERIAL CHANGES SHOWN IN RED.		AS-BUILT COPY	
FOREMAN'S SIG NATURE _____ DATE _____		FOREMAN'S SIG NATURE _____ DATE _____		SUPERVISOR'S SIG NATURE _____ DATE _____		INITIALS _____ CERT. DATE _____	
Easement? Yes <input type="checkbox"/> No <input checked="" type="checkbox"/>		Survey/Stake? Yes <input type="checkbox"/> No <input checked="" type="checkbox"/>		Work with SMO? Yes <input type="checkbox"/> No <input checked="" type="checkbox"/>		FPL City of Fort Lauderdale - New SL 1000 NE 16th PL 1 New light 1000 NE 16th PL, FORT LAUDERDALE, FL 33305	
Tree Work? Yes <input type="checkbox"/> No <input checked="" type="checkbox"/>		Designer/Stake? Yes <input type="checkbox"/> No <input checked="" type="checkbox"/>		CT/Special Mtr? Yes <input type="checkbox"/> No <input checked="" type="checkbox"/>			
PERMIT REQ'D: City <input checked="" type="checkbox"/> County Rd. <input type="checkbox"/> County Air <input type="checkbox"/> State Road <input type="checkbox"/> FAA <input type="checkbox"/> WMD <input type="checkbox"/> RR Xing <input type="checkbox"/> DR. Dist. <input type="checkbox"/> Transm. <input type="checkbox"/>		Tele. Attachment Per _____ Telephone Co. Job No. _____		Designed by: Thais Garcia Date: 03/15/22 Drawn by: TG Check by: _____ Dwg No. 5 OF 8			
Requested Tel. Co. Set Poles? YES <input type="checkbox"/> NO <input checked="" type="checkbox"/> Requested Tel. Co. Transfer? YES <input type="checkbox"/> NO <input checked="" type="checkbox"/> Request CAVT Transfer? YES <input type="checkbox"/> NO <input checked="" type="checkbox"/>		POLE LINE FEET 0' DUCT BANK FT. 0' POLE LINE FT. ON TRANSM. POLES 0' TRENCH FT. 0'		Rural Location Sec. xx TWP. xx S, RGE. xx E. SCALE: N.T.S St. Lt MAP No. MAP# Pri Map No. xxxxxx		TLM/LDS MODEL No. - Map Posting? YES <input checked="" type="checkbox"/> NO <input type="checkbox"/> Posted by: WR xxxxxx M/A xx	

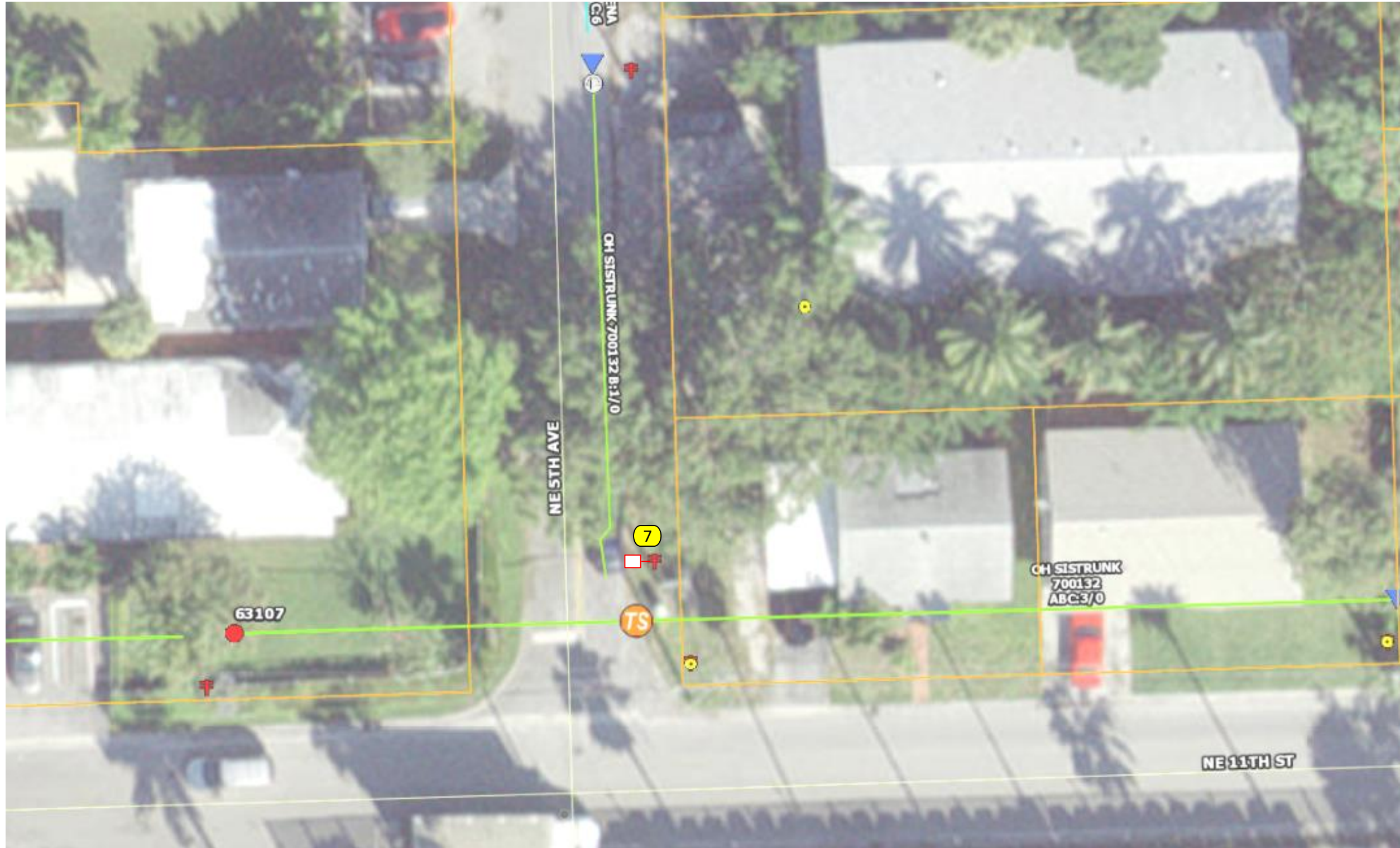

Construction Notes: (FPL contractor installing conduit)

Loc. 7: Install 1 Roadway 5,000L 42W 3K LED with 6ft bracket on existing distribution pole.

- Customer responsible for any restoration required.

Sales Rep: Marlon Barrios

AS-BUILT CREW PRINT		ALL REQUIRED GROUND RODS HAVE BEEN DRIVEN & VERIFIED TO BE WITHIN FPL STANDARDS. VALUES ARE SHOWN AT ALL LOCATIONS.		JOB CERTIFIED COMPLETED AS SHOWN ON THIS AS-BUILT PRINT. MATERIAL CHANGES SHOWN IN RED.		AS-BUILT COPY			
FOREMAN'S SIG NATURE _____ DATE _____		FOREMAN'S SIG NATURE _____ DATE _____		SUPERVISOR'S SIG NATURE _____ DATE _____		INITIALS _____ CERT. DATE _____			
Easement?	Yes <input type="checkbox"/> No <input checked="" type="checkbox"/>	Survey/Stake?	Yes <input type="checkbox"/> No <input checked="" type="checkbox"/>	Work with SMO?	Yes <input type="checkbox"/> No <input checked="" type="checkbox"/>	FPL City of Fort Lauderdale - New SL 1000 NE 16th PL 1 New light 1000 NE 16th PL, FORT LAUDERDALE, FL 33305			
Tree Work?	Yes <input type="checkbox"/> No <input checked="" type="checkbox"/>	Designer/Stake?	Yes <input type="checkbox"/> No <input checked="" type="checkbox"/>	CT/Special Mtr?	Yes <input type="checkbox"/> No <input checked="" type="checkbox"/>				
PERMIT REQ'D	City <input checked="" type="checkbox"/> County Rd. <input type="checkbox"/> County Air <input type="checkbox"/> State Road <input type="checkbox"/> FAA <input type="checkbox"/>	RR Xing <input type="checkbox"/> DR. Dist. <input type="checkbox"/> Transm. <input type="checkbox"/>	Tele. Attachment Per _____ Telephone Co. Job No. _____						
Requested Tel. Co. Set Poles?	YES <input type="checkbox"/> NO <input checked="" type="checkbox"/>	Requested Tel. Co. Transfer?	YES <input type="checkbox"/> NO <input checked="" type="checkbox"/>	Request CAVT Transfer?	YES <input type="checkbox"/> NO <input checked="" type="checkbox"/>	Designed by:	Thais Garcia		
POLE LINE FEET		0'	DUCT BANK FT.	0'	Date:			03/15/22	
POLE LINE FT. ON TRANSM. POLES		0'	TRENCH FT.	0'	Drawn by:	TG	Check by:	Dwg No.	6 OF 8
TLM/LDS MODEL No.		-	Map Posting?	YES <input checked="" type="checkbox"/> NO <input type="checkbox"/>	Posted by:	WR	xxxxxxx	M/A	xx

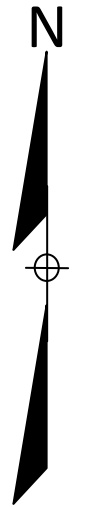

Footage: 102 ft.

**Permit required with
City of Fort Lauderdale**

Construction Notes: (FPL contractor installing conduit)

Loc. 8: Install 1 Roadway 5,000L 42W 3K LED with 6ft bracket on NEW 35' standard street light concrete pole.
Loc. F: Install 2" riser.

FPL contractor to install 2" flex pipe with 24" minimum cover as shown in the drawing using directional bore. Cable to be used is #6 DPX. FPL contractor installing hand-holes and staking locations of the poles. Pole on this page to be installed in R/W in the back-end of the sidewalk.

- Customer responsible for any restoration required. All hand-holes to be 17" unless noted.

Sales Rep: Marlon Barrios

AS-BUILT CREW PRINT		ALL REQUIRED GROUND RODS HAVE BEEN DRIVEN & VERIFIED TO BE WITHIN FPL STANDARDS. VALUES ARE SHOWN AT ALL LOCATIONS.		JOB CERTIFIED COMPLETED AS SHOWN ON THIS AS-BUILT PRINT. MATERIAL CHANGES SHOWN IN RED.		AS-BUILT COPY	
FOREMAN'S SIG NATURE _____ DATE _____		FOREMAN'S SIG NATURE _____ DATE _____		SUPERVISOR'S SIG NATURE _____ DATE _____		INITIALS _____ CERT. DATE _____	
Easement? Yes <input type="checkbox"/> No <input checked="" type="checkbox"/>		Survey/Stake? Yes <input type="checkbox"/> No <input checked="" type="checkbox"/>		Work with SMO? Yes <input type="checkbox"/> No <input checked="" type="checkbox"/>		FPL City of Fort Lauderdale - New SL 1000 NE 16th PL 1 New light 1000 NE 16th PL, FORT LAUDERDALE, FL 33305	
Tree Work? Yes <input type="checkbox"/> No <input checked="" type="checkbox"/>		Designer/Stake? Yes <input type="checkbox"/> No <input checked="" type="checkbox"/>		CT/Special Mtr? Yes <input type="checkbox"/> No <input checked="" type="checkbox"/>			
PERMIT REQ'D	City <input checked="" type="checkbox"/>	County Rd.	County Air	State Road	FAA	Designed by: Thais Garcia Date: 03/15/22 Drawn by: TG Check by: Dwg No. 7 OF 8	
	WMD	RR Xing	DR. Dist.	Transm.			
Requested Tel. Co. Set Poles? YES <input type="checkbox"/> NO <input checked="" type="checkbox"/>		Requested Tel. Co. Transfer? YES <input type="checkbox"/> NO <input checked="" type="checkbox"/>		Request CAVT Transfer? YES <input type="checkbox"/> NO <input checked="" type="checkbox"/>		Rural Location Sec. xx TWP. xx S, RGE. xx E.	
POLE LINE FEET 0'		DUCT BANK FT. 0'		TRENCH FT. 0'		SCALE: N.T.S. St. Lt MAP No. MAP# Pri Map No. xxxxxx	
TLM/LDS MODEL No. -		Map Posting? YES <input checked="" type="checkbox"/> NO <input type="checkbox"/>		Posted by:		WR xxxxxx M/A xx	

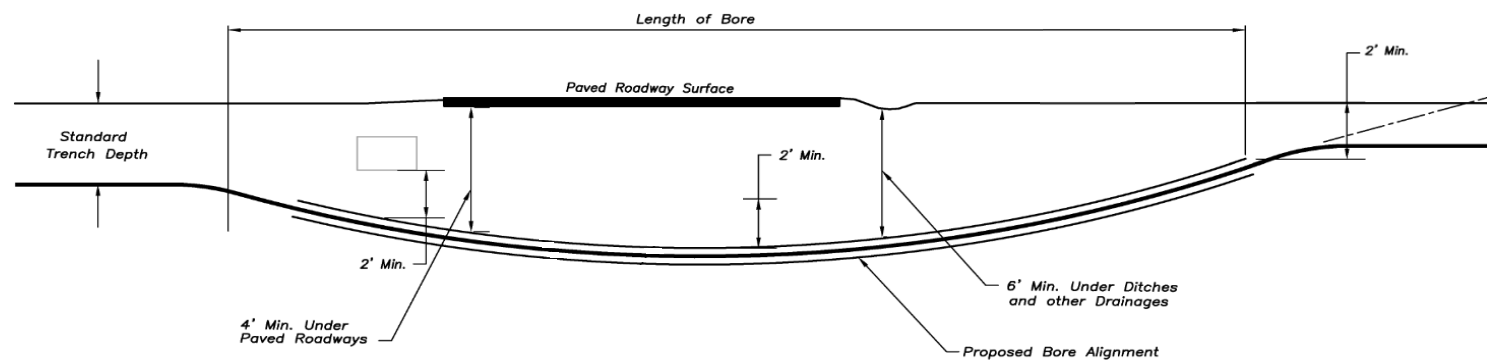
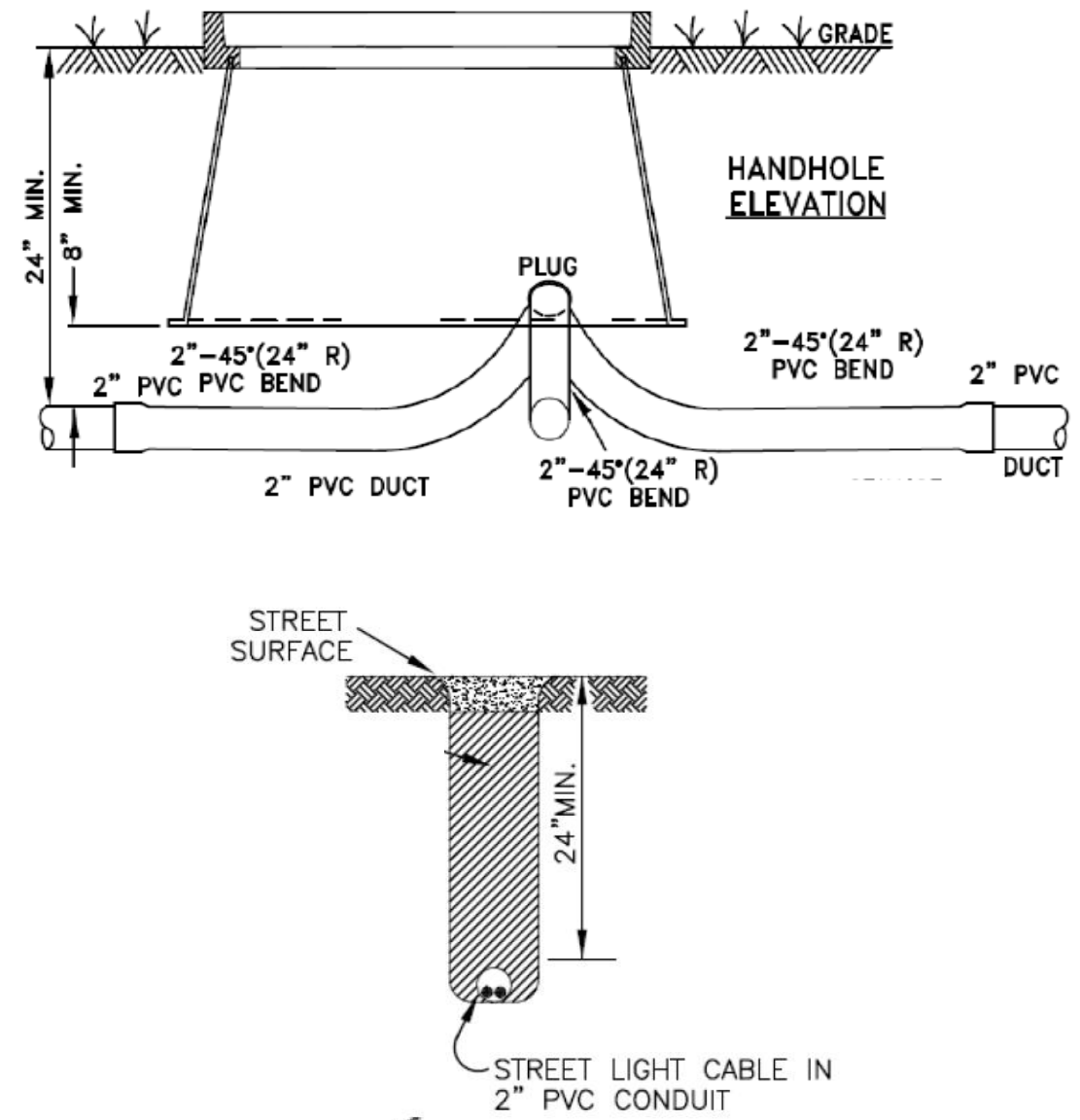

H-7.0.1 STREET LIGHT UNDERGROUND INSTALLATIONS H-7.0.1

STRAIGHT SHEAR BOLT CONNECTOR M&S #163-050-002

OH SERVICE POINT

2" U-GUARD (SEE NOTES 9 & 10, H-7.0.2)

24" MIN. COVER IN UNPAVED AREAS

SEE NOTE 8 H-7.0.2

SEE NOTES 4 & 6 H-7.0.2

RUN/TAP

BURIED COMMUNICATION CABLE (SEE NOTE 1, H-7.0.2)

UG SERVICE POINT FUSING SEE H-3.0.0

24" MIN. COVER UNDER SIDEWALK

2/C #6AL ST LT CBL (100-302-005) IN 2" PVC CONDUIT (SEE NOTE 2, H-7.0.2)

24" MIN. COVER UNDER STREET PAVEMENT (SEE NOTE 5, H-7.0.2)

2/C #12CU (110-104-001) POLE & BKT. CONDUCTOR

SHEAR BOLT CONNECTOR M&S #163-050-001

TAP RUN

TELEPHONE CABLE (TEL)

ELECTRICAL CONNECTIONS FOR POLES ON STREETS SHOULD BE MADE ON THE OPPOSITE SIDE FROM ONCOMING TRAFFIC. (SEE NOTE 7, H-7.0.2)

NOTES:

- FOR #6 AL DPX OR #1/0 AL TPX RUNS, USE SHEAR BOLT CONNECTOR M&S 163-050-001 AND A SHORT 1/2" 6 POINT SOCKET (M&S #594-955-004) TO CONNECT #12CU CONDUCTORS TO FEED INDIVIDUAL LUMINAIRES.
- FOR #4/0 AL TPX RUNS, USE SHEAR BOLT CONNECTORS AS SHOWN ON L-17.0.9.
- FOR DIRECT FEED TO SINGLE STREET LIGHT, USE CONNECTOR M&S #163-050-002 AND A SHORT 3/4" 6 POINT SOCKET (M&S #594-955-002).
- SEE H-7.1.1 FOR INSTALLATION DETAILS.

SUPERSEDES H-7.0.1 LAST REVISED ON 1-29-92

6	11/4/16	UPDATE DRAWING & TEXT	JCH	ELS	BDH
5	3/9/11	UPDATE DRAWING & TEXT	ARR	ELS	BXN
4	1/3/11	UPDATE TEXT	ARR	ELS	BXN
3	5/28/09	UPDATE TEXT	SMS	ELS	JJM
2	6/10/03	UPDATE DRAWING & TEXT	SMS	ELS	JJM
1	9/22/99	UPDATE DRAWING & TEXT	SMS	JES	JJM
NO.	DATE	REVISION	ORIG.	DRAWN	APPR.

F P L
OH & UG DISTRIBUTION SYSTEM STANDARDS
ORIGINATOR: JBM DRAWN BY: RAS
DATE: 1/29/92 APPROVED: J.J. McEVoy SUPERVISOR, OH/UG PRODUCT SUPPORT SERVICES

AS-BUILT CREW PRINT		ALL REQUIRED GROUND RODS HAVE BEEN DRIVEN & VERIFIED TO BE WITH FPL STANDARDS, VALUES ARE SHOWN AT ALL LOG TAGS.		JOB CERTIFIED COMPLETED AS SHOWN ON THIS AS-BUILT PRINT. MATERIAL CHANGES SHOWN ON ROS.		AS-BUILT COPY	
FOREMAN'S SIGNATURE _____ DATE _____		FOREMAN'S SIGNATURE _____ DATE _____		SUPERVISOR'S SIGNATURE _____ DATE _____		INITIALS _____ CERT. DATE _____	
Easement?	Yes <input type="checkbox"/> No <input checked="" type="checkbox"/>	Survey/Stake?	Yes <input type="checkbox"/> No <input checked="" type="checkbox"/>	Work with SMO?	Yes <input type="checkbox"/> No <input checked="" type="checkbox"/>	FPL City of Fort Lauderdale - New SL 1000 NE 16th PL 1 New light 1000 NE 16th PL, FORT LAUDERDALE, FL 33305 Designed by: Thais Garcia Date: 03/15/22 Drawn by: TG Check by: _____ Dwg No. 8 OF 8 Rural Location Sec. xx TWP. xx S, RGE. xx E. SCALE: N.T.S. St. Lt MAP No. MAP# Pri Map No. xxxxxx TLM/LDS MODEL No. - Map Posting? YES <input checked="" type="checkbox"/> NO <input type="checkbox"/> Posted by: WR xxxxxx M/A xx	
Tree Work?	Yes <input type="checkbox"/> No <input checked="" type="checkbox"/>	Designer/Stake?	Yes <input type="checkbox"/> No <input checked="" type="checkbox"/>	CT/Special Mtr?	Yes <input type="checkbox"/> No <input checked="" type="checkbox"/>		
PERMIT REQ'D	City <input checked="" type="checkbox"/> County Rd. _____ County Air _____ State Road _____ FAA _____	WMD	RR Xing	DR. Dist.	Transm.		
Requested Tel. Co. Set Poles?	YES <input type="checkbox"/> NO <input checked="" type="checkbox"/>	Requested Tel. Co. Transfer?	YES <input type="checkbox"/> NO <input checked="" type="checkbox"/>	Request CAVT Transfer?	YES <input type="checkbox"/> NO <input checked="" type="checkbox"/>		
POLE LINE FEET	0'	DUCT BANK FT.	0'	POLE LINE FT. ON TRANSM. POLES	0'	TRENCH FT.	0'