



CITY OF FORT LAUDERDALE

**DRAFT**  
**MEETING MINUTES**  
**CITY OF FORT LAUDERDALE**  
**MARINE ADVISORY BOARD**  
**THURSDAY, NOVEMBER 4, 2021 – 6:00 P.M.**

		<b>Cumulative Attendance</b>	
		<b>May 2021 – April 2022</b>	
Grant Henderson, Chair	P	6	0
Ed Strobel, Vice Chair	P	6	0
Deirdre Boling-Lewis	A	4	2
Robyn Chiarelli	A	2	4
Bob Denison	P	4	1
Barry Flanigan	P	5	1
Richard Graves	P	3	3
James Harrison	P	6	0
Rose Ann Lovell	P	5	1
Kitty McGowan	P	5	1
Norbert McLaughlin	P	6	0
Ted Morley	P	5	1
Noelle Norvell	P	2	1
Christopher Rotella	P	6	0
Steve Witten	P	6	0

As of this date, there are 15 appointed members to the Board, which means 8 would constitute a quorum.

**Staff**

Andrew Cuba, Marine Facilities Manager  
Jonathan Luscomb, Marine Facilities Supervisor  
Sergeant Tom Capano, Fort Lauderdale Police Department  
Tedra Allen, Recording Secretary, Prototype, Inc.

**Communications to City Commission**

None.

**I. Call to Order / Roll Call**

Chair Henderson called the meeting to order at 6:02 p.m.

**II. Approval of Minutes – October 7, 2021**

**Motion** made by Mr. Harrison, seconded by Vice Chair Strobel, to approve. In a voice vote, the **motion** passed unanimously.

### **III. Statement of Quorum**

It was noted a quorum was present at the meeting.

Chair Henderson advised that Item VI has been deferred to a later date.

### **IV. Waterway Crime & Boating Safety Report**

Sergeant Tom Capano of the Fort Lauderdale Police Department's Marine Unit reported the following activity from October 2021:

- 44 citations
- 50 warnings
- 3 vessel burglaries
- 2 boating accidents

The Marine Unit has also performed speed zone enforcements south of Oakland Park. Over the past 30 days, they have written 12 citations in that area alone, in addition to the citations noted above.

Chair Henderson requested an update on the Fort Lauderdale International Boat Show. Sgt. Capano advised that there was heavy marine traffic on the Intracoastal Waterway, but there were no other issues.

Additional information was requested regarding motorized surfboards. Sgt. Capano replied that these must follow the same safety requirements as paddleboards and kayaks. He added that he would look into whether or not FM numbers will be required, as these are motorized vessels and must comply with wake requirements as well.

### **V. Dock Permit – 1725 SE 8<sup>th</sup> Street / W. Scott and Patricia S. Parker**

Scott Parker, Applicant, stated that there is a 100 ft. concrete dock on the property, as well as landscaping and an irrigation system. He has no plans to include a boat lift. The Application is for a permit to use the existing dock. No new pilings have been constructed on the back side of the subject property, which means he would need to install them if he wished to tie a boat to that side.

There being no further questions from the Board at this time, Chair Henderson opened the public hearing. As there were no individuals wishing to speak on this Item, the Chair closed the public hearing and brought the discussion back to the Board.

Mr. Cuba clarified that the request is for a dock permit under Section 144 of Code, which addresses private use of public property.

**Motion** made by Mr. McLaughlin, seconded by Mr. Harrison, to approve.

It was asked if similar permits will need to be granted for all residents along Cordova Road who wish to use the seawall there. Mr. Cuba explained that this is a required process for every home along Cordova Road that wishes to use dock space on public property. He estimated that this requirement applies to approximately 40 properties in that area.

In a voice vote, the **motion** passed unanimously.

**VI. Dock Permit – 625 SW 5<sup>th</sup> Place / Daniel Cole**

This Item was deferred.

**VII. Dock Permit – 805 Cordova Road / Michael Redmond**

Jena Robbins, representing the Applicant, explained that this request is also for private use of public property abutting waterways. She showed multiple views of the property, noting that the seawall at this location has recently been installed. The Applicant's property is located on the west side of Cordova Road.

Ms. Robbins also showed depictions of the public swale area to the west side of the seawall all along the property, as well as the dock along the east side of the seawall. The property is zoned RS-8, which requires a 5 ft. side yard setback. The Applicant requests approval of a composite fixed T dock in the middle of the property along the seawall, as well as two floating docks on either side of the fixed structure. These extend roughly 60 x 8 ft. A ramp and platform are proposed on the western side of the seawall for access to the docks.

All structures and piles will not exceed 30% of the width of the waterway. The Applicant previously owned existing and fixed floating docks that were removed due to the City's Cordova Road Seawall Project. A landscaping plan was submitted as part of the Application, and permit applications have been submitted to the appropriate environmental agencies. The U.S. Army Corps of Engineers has issued a permit, while Broward County is still reviewing the permit submitted to them. Three letters of support have been provided from adjacent neighbors and an additional letter was provided from a property owner on the south side of the bridge.

The Applicant requests approval of the Application with the landscaping plan. Mr. Cuba advised that Code Section 8-144, Subsection 7 addresses permitted landscaping as authorized by the City.

Tyler Chappell, also representing the Applicant, further clarified that an advisory committee has been established for the Rio Vista neighborhood to look at landscaping plans along Cordova Road and work with City Staff to make the seawall more compatible with its surroundings. The Applicant was given a template by the City Attorney's Office, which is expected to be updated in the near future for upcoming dock

permit requests. He confirmed that the Applicant would welcome any revisions to the landscaping plan for the roadway, with the understanding that any landscaping improvements or access to docks must go through the City's building process.

Mr. Flanigan asked if the City has provided direction regarding a ramp or stairs to get over the seawall. Mr. Chappell replied that the Applicant was provided a template for stair or step detail, which has been used in past applications. The City Attorney has requested that Exhibit A of the Applicant's presentation, which shows the location of the seawall in relation to the swale area and the water, encompass landscape detail into any Resolution of approval.

It was asked whether any representation was made to property owners in the subject area regarding what structures removed from the waterway could be replaced once the new seawall was complete. Mr. Cuba replied that there is verbiage in Code Section 8-144, also included in the Board members' backup materials, which speaks to the option of installing a fixed or floating dock. No template was provided for the replacement of structures.

There being no further questions from the Board at this time, Chair Henderson opened the public hearing. As there were no individuals wishing to speak on this Item, the Chair closed the public hearing and brought the discussion back to the Board.

**Motion** made by Vice Chair Strobel, seconded by Ms. McGowan, to approve, with one condition that they work with the future City landscape plan.

There was consensus among the Board members that landscaping is outside their purview. Mr. Cuba advised that he would seek additional clarification on landscaping for informational purposes.

Vice Chair Strobel further clarified that his **motion** was intended to recommend that the Applicant refrain from doing any landscaping until the City has granted its approval to do so. Mr. Cuba confirmed that the Board may make conditional **motions** such as this, noting that the Applicant may move forward with landscaping as long as the plan is deemed acceptable by the appropriate City Staff. A separate Declaration of Covenant will be required prior to Commission approval of the Application, which includes more specific landscaping details.

Mr. Harrison and Ms. Lovell expressed concern that the Applicant could be delayed in implementing the required landscaping, which lies outside the Board's purview. Vice Chair Strobel offered to withdraw his earlier **motion** and restate it without the reference to landscaping.

Vice Chair Strobel **amended** his **motion** as follows: **motion** to just approve. Mr. Rotella **seconded** the **motion**.

In a roll call vote, the **motion** passed unanimously (13-0).

**VIII. Dock Permit – 1532 Ponce de Leon Drive / Jeffrey Cantor & Myrna Roberts**

Jena Robbins, representing the Applicants, stated that this Application also requests private use of public property abutting waterways. The Applicants' property is located on the west side of Cordova Road and the new seawall was installed along the east side of this roadway. She showed multiple views of the subject area, including the new seawall, concrete hatch, and public swale area.

The Applicants propose a 65 ft. long, 7 ft. wide wooden dock for a total of 455 sq. ft. They also propose a platform off the fixed dock so they may descend the ramp to a 30 x 8 ft. floating dock. To access the seawall and dock, a platform and ramp are proposed along the public swale area. These structures will not exceed 30% of the width of the waterway. The Applicant has submitted a landscaping plan along with the Application.

The Army Corps of Engineers has issued an environmental resource permit for the proposed docks, and the County permit is under review by the Broward County Environmental Protection and Growth Management Department.

It was noted that most of the neighbors in the subject area are in favor of allowing this type of private use of public property, and many of them may also submit applications for waterfront access on Cordova Road for themselves.

There being no further questions from the Board at this time, Chair Henderson opened the public hearing. As there were no individuals wishing to speak on this Item, the Chair closed the public hearing and brought the discussion back to the Board.

**Motion** made by Mr. Morley, seconded by Mr. Harrison, to approve as presented. In a roll call vote, the **motion** passed unanimously (13-0).

**IX. Old / New Business**

Mr. Rotella stated that one of his concerns for the City was to ensure Fort Lauderdale's waterways are cleaned. He recommended that the Board consider starting a program to improve the City's waterway quality for the safety of both humans and animals.

Chair Henderson advised that he has spoken with an individual involved in waterway cleanup who is willing to make a presentation to the Board. Additional information can also be provided on the steps the City is already taking toward the goal of cleaner water. Mr. Rotella recalled seeing presentations from scientists at the recent Boat Show, and urged Fort Lauderdale to set an example for the rest of the world.

Mr. McLaughlin commented that when a developer brings a presentation or application before the Board, and the application or presentation later undergoes a change of 10% or more, the developer is supposed to bring the item back before them. He pointed out that there are recent developments, such as the Las Olas Marina or a handrail for the Ikon property, that have not fulfilled this requirement.

Mr. Graves asked if this was a requirement when the changes proposed are on the upland side of an application rather than for marine features. Mr. McLaughlin pointed out that the Ikon item not brought back before the Board involves a walkway over the water. He asserted that this is related to safety, navigation, and the environment. Mr. Graves noted that a development such as the Las Olas Marina may make changes to features such as its upland restaurant, which he did not feel was within the Board's purview.

## **X. Adjournment**

There being no further business to come before the Board at this time, the meeting was adjourned at 6:51 p.m.

Any written public comments made 48 hours prior to the meeting regarding items discussed during the proceedings have been attached hereto.

[Minutes prepared by K. McGuire, Prototype, Inc.]

# ITEM V

## MEMORANDUM MF NO. 21-30

DATE: November 9, 2021

TO: Marine Advisory Board Members

FROM: Andrew Cuba, Manager of Marine Facilities

RE: December 2, 2021 MAB Meeting – Application for Dock Permit – Edward & Elizabeth Bohne / 721 Cordova Road

Attached for your review is an application from Edward & Elizabeth Bohne / 721 Cordova Road (see **Exhibit 1**).

### APPLICATION AND BACKGROUND INFORMATION

The applicant is seeking approval for the installation of an L-shaped fixed wood dock, a 20' x 5' floating dock, access gangway, a 30,000 pound boat lift and seawall access stairs extending a maximum of +/- 30' from the wet face of the seawall on public property abutting the waterway adjacent to 721 Cordova Road (see **Exhibit 1**). City Code Section 8-144 (**Exhibit 2**) authorizes the construction and use of docks on public property, and allows for the permit to be issued provided the permit holder agrees to maintain the improvements and seawall. A separate Dock Waiver is required to extend the proposed mooring structures beyond 25' per ULDR 47-19.3 (C).

### PROPERTY LOCATION AND ZONING

The property is located within the Rio Vista Isles RS-8 Residential Low Density Zoning District. The dock area is directly adjacent to Lake Juanita with direct access to the Intracoastal Waterway.

### ENGINEERING REVIEW REQUIREMENT

As a requirement of City Code Section 8-144, approval of the application is contingent upon all improvements to the property being maintained in accord with City Engineering standards and in full compliance with building and zoning regulations including construction permits required for any future electrical and water feeds to the property.

The granting of this Permit is subject to all of the provisions of City Code Section 8-144 as well as the following terms and conditions, violation of any of which shall be grounds for revocation of the Permit:

1. The permit to use the docks shall expire upon the: (i) abandonment of the use of the dock; or (ii) recordation of the deed of conveyance transferring title to the upland parcel; or (iii) termination, expiration or revocation of the dock permit by the City Commission, whichever (i),(ii), or (iii) shall first occur.
2. Upon expiration of the permit to use the dock, the permit holder shall be obligated to remove the dock and all appurtenances thereto no later than three (3) months after the termination, revocation or expiration of the permit to use the dock.
3. Signage such as "private dock" may be placed on the dock within the dock area, but not upon or within the public swale area.

Marine Advisory Board

December 2, 2021

Page 2

4. Only vessels owned by the permit holder and registered with the City as part of the dock permit application may be moored at the permitted dock.
5. During the term of the dock permit, the permit holder shall be required to repair, replace, reconstruct or maintain the dock or adjacent seawall or both to meet the requirements of City Code 8-144 (7) and ULDR section 47-19.3 (f).(4.). The public swale area shall be landscaped in accordance with the established landscape plan for the area in question adopted by the Department of Sustainable Development.
6. All improvements such as docks, seawalls and the like which are placed upon the public dock area or within the dock permit parcel or within the dock area and public swale area by a private person shall be constructed with appropriate permits from all applicable agencies. Maintenance and repairs shall be performed according to City Engineering standards and all applicable regulatory codes. Penetration of the seawall is prohibited unless as otherwise provided in 8-144 (6).
7. The public swale area shall be kept open at all times as means of reasonable ingress and egress to the public, but the permit holder shall have the right to exclude the public from the dock area.
8. Vessels berthed within the Dock Area must not encroach into the northerly or southerly extension of the 5' set-back required for the RS-8 zoning district for Applicant's (Permit Holder's) Property.
9. All installed docks must be either (i)floating docks that can adapt to seal level rise over their useful life span; or (ii) fixed docks installed at a minimum height consistent with the requirements of section 47-19.3(f); or (iii) fixed docks the height of which are even with the City's seawall, whichever (ii) or (iii) is the greater.
10. Except as to a tender, there shall be no rafting of vessels from the moored vessel.
11. The permit shall guarantee from the permit holder to the city to indemnify and hold the city harmless for any damage or injury to any person using such facilities.
12. The violation of any provisions of Code Section 8-144 or violations of any of the terms or conditions relative to the granting or renewal of a dock permit shall be unlawful and may constitute cause for revocation of the permit. The Applicant is responsible to execute and deliver a Declaration of Covenants Running With The Land to the City Attorney's Office no later than ten (10) days prior to City Commission review date.

AC

Attachment

cc: Enrique Sanchez, Deputy Director of Parks and Recreation  
Jonathan Luscomb, Marine Facilities Supervisor

# **DOCK & BOATLIFT PERMIT APPLICATION**

**EDWARD & ELIZABETH BOHNE**

**721 CORDOVA ROAD**

**FORT LAUDERDALE, FL 33316**

*721 CORDOVA ROAD, FORT LAUDERDALE, FL 33316*

*EDWARD & ELIZABETH BOHNE • 954-444-2234 • TED@ZCONSTRUCTIONINC.COM*

# **DOCK & BOATLIFT PERMIT APPLICATION**

## **TABLE OF CONTENTS**

Project Description	Page 3
Application	Page 4-5
Warranty Deed & BCPA Information	Page 6-10
Survey	Page 11-12
Site Photos	Page 13-16
Vessel Information	Page 17-19
Project Plans & Engineering	Page 20-26
Landscaping Plan	Page 27-28
Exhibit A	Page 29-30
Aerial Photo	Page 31-32

## **PROJECT DESCRIPTION**

The applicants are seeking approval to construct a dock and boatlift on the public property abutting the waterway adjacent to their residence at 721 Cordova Road.

The proposed project, for the private use and enjoyment of the applicants and their personal vessel, includes: a set of stairs to provide access over seawall cap; an L-shaped fixed wood dock of ± 276 square feet; a 4' x 16' aluminum gangway; a 20' x 5' floating dock; and a 30,000 pound capacity cradle boatlift.

Environmental permits will be obtained from FDEP, Army Corps of Engineers and Broward County prior to obtaining a building permit from the City of Fort Lauderdale.

*721 CORDOVA ROAD, FORT LAUDERDALE, FL 33316*

*EDWARD & ELIZBETH BOHNE • 954-444-2234 • TED@ZCONSTRUCTIONINC.COM*

# **APPLICATION FOR WATERWAY PERMIT**

*721 CORDOVA ROAD, FORT LAUDERDALE, FL 33316*

*EDWARD & ELIZBETH BOHNE • 954-444-2234 • TED@ZCONSTRUCTIONINC.COM*

**CITY OF FORT LAUDERDALE  
MARINE FACILITIES  
APPLICATION FOR WATERWAY PERMITS, WAIVERS AND LICENSES**

Any agreement with the City of Fort Lauderdale and other parties, such as, but not limited to, licenses, permits and approvals involving municipal docking facilities or private uses in the waterways as regulated by Section 8 of the City Code of Ordinances or Section 47-19.3 of the City's Urban Land Development Regulations, shall be preceded by the execution and filing of the following application form available at the Office of the Supervisor of Marine Facilities. The completed application must be presented with the applicable processing fee paid before the agreement is prepared or the application processed for formal consideration (see City of Fort Lauderdale Code Section 2-157). If legal publication is necessary, the applicant agrees to pay the cost of such publication in addition to the application fee.

**APPLICATION FORM  
(Must be in Typewritten Form Only)**

1. LEGAL NAME OF APPLICANT - (If corporation, name and titles of officers as well as exact name of corporation. If individuals doing business under a fictitious name, correct names of individuals, not fictitious names, must be used. If individuals owning the property as a private residence, the name of each individual as listed on the recorded warranty deed):

NAME: **Edward & Elizabeth Bohne**

TELEPHONE NO: 954-444-2234 EMAIL ted@zconstructioninc.com  
(home/cellular)

2. APPLICANT'S ADDRESS (if different than the site address):  
**same**

3. TYPE OF AGREEMENT AND DESCRIPTION OF REQUEST:  
**Dock Permit**

4. SITE ADDRESS: **721 Cordova Road, Fort Lauderdale 33316** ZONING: **RS-8**

LEGAL DESCRIPTION AND FOLIO NUMBER:  
**RIO VISTA ISLES UNIT 3 7-47 B LOT 47 S 33.34 LESS W 2 OF S 20, 48 N 33.33 LESS W 2 BLK 30  
504211183660**

5. EXHIBITS (In addition to proof of ownership, list all exhibits provided in support of the applications).  
**Survey, plans,**

 \_\_\_\_\_ 9/28/21  
Applicant's Signature Date

=====

The sum of \$ \_\_\_\_\_ was paid by the above-named applicant on the \_\_\_\_\_ of \_\_\_\_\_,  
20\_\_\_\_ Received by: \_\_\_\_\_  
City of Fort Lauderdale

=====For Official City Use Only=====

**Marine Advisory Board Action**  
Formal Action taken on \_\_\_\_\_

**Commission Action**  
Formal Action taken on \_\_\_\_\_

Recommendation \_\_\_\_\_  
Action \_\_\_\_\_

# **WARRANTY DEED & BCPA INFORMATION**

*721 CORDOVA ROAD, FORT LAUDERDALE, FL 33316*

*EDWARD & ELIZBETH BOHNE • 954-444-2234 • TED@ZCONSTRUCTIONINC.COM*

**This Document Prepared By:**

Bruce K. Herman, Esq., The Herman Law Group, P.A.  
3020 NE 32nd Avenue, Suite 226  
Fort Lauderdale, FL 33308

**Return to:**

Balocco & Abril, PLLC, 4332 East Tradewinds Avenue  
Lauderdale By-The-Sea, FL 33308

Parcel ID Number: 504211-18-3660

## Warranty Deed

This Indenture, Made this 7<sup>th</sup> day of **June**, 2021 A.D., **Between**  
**Louise Dekok, a married woman**  
of the County of **Broward**, State of **Florida**, **grantor**, and  
**Edward J. Bohne, III and Elizabeth Ellen Bohne, husband and wife**  
whose address is: **721 Cordova Road, Fort Lauderdale, FL 33316**  
of the County of **Broward**, State of **Florida**, **grantees.**

**Witnesseth** that the GRANTOR, for and in consideration of the sum of

**TEN DOLLARS (\$10)**

and other good and valuable consideration to GRANTOR in hand paid by GRANTEES, the receipt whereof is hereby acknowledged, has granted, bargained and sold to the said GRANTEES and GRANTEES' heirs, successors and assigns forever, the following described land, situate, lying and being in the County of **Broward**, State of **Florida** to wit:

**See Exhibit "A" attached hereto and made a part hereof.**

**NOTE: This property is NOT the Homestead Property for the Grantor, Louise Dekok. Her Homestead address is 1409 SE 11th Court, Fort Lauderdale, FL 33316.**

**Subject to taxes for 2021 and subsequent years; covenants, conditions, restrictions, easements, reservations and limitations of record, if any.**

**Together with all the tenements, hereditaments and appurtenances thereto belonging or in anywise appertaining.**

**To Have and to Hold, the same in fee simple forever.**

**And the grantor hereby covenants with said grantee that the grantor is lawfully seized of said land in fee simple; that the grantor has good right and lawful authority to sell and convey said land; that the grantor hereby fully warrants the title to said land and will defend the same against the lawful claims of all persons whomsoever; and that said land is free of all encumbrances, except taxes accruing subsequent to December 31, 2020.**

and the grantor does hereby fully warrant the title to said land, and will defend the same against lawful claims of all persons whomsoever.

# Warranty Deed - Page 2

Parcel ID Number: 504211-18-3660

In Witness Whereof, the grantor has hereunto set her hand and seal the day and year first above written.

Signed, sealed and delivered in our presence:

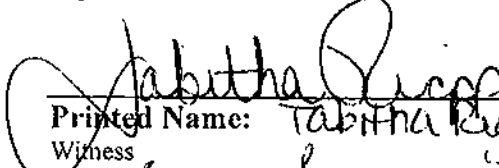
  
 Printed Name: Tabitha Riggs  
 Witness

  
 Louise Dekok (Seal)  
 P.O. Address: 1409 SE 11th Court, Fort Lauderdale, FL 33316

  
 Printed Name: LISA A. FEIX  
 Witness

State of Florida  
County of Broward

The foregoing instrument was acknowledged before me by means of  physical presence or  online notarization, this 7<sup>th</sup> day of June, 2021, by Louise Dekok who is personally known to me or who has produced her **Florida's driver license** as identification .

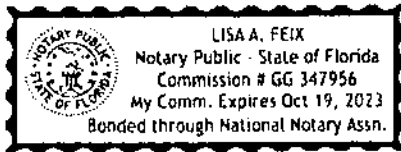

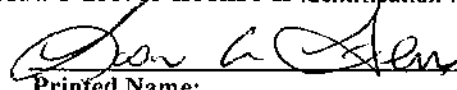
  
 Printed Name: \_\_\_\_\_  
 Notary Public  
 My Commission Expires: \_\_\_\_\_

## Exhibit A

The South 33.34 feet (measured along the front or East lot line) of Lot 47 and the North 33.33 feet (measured along the front or East lot line) of Lot 48, Block 30, RIO VISTA ISLES, UNIT 3; less a strip of land being two feet (2') in width, lying adjacent to and immediately East of the West line of the South twenty feet (S 20') of Lot 47, Block 30, RIO VISTA ISLES, UNIT 3; less also a strip of land being two feet (2') in width, lying adjacent to and immediately East of the West line of the North 33.33 feet of Lot 48, Block 30, RIO VISTA ISLES, UNIT 3, according to the Plat thereof, recorded in Plat Book 7, Page 47, of the Public Records of Broward County, Florida.

**PROPERTY SUMMARY**

<b>Tax Year:</b> 2022	<b>Property Use:</b> 01 - Single family	<b>Deputy Appraiser:</b> Residential Department
<b>Property Id:</b> 504211183660	<b>Millage Code:</b> 0312	<b>Appraisers Number:</b> 954-357-6831
<b>Property Owner/s:</b> BOHNE,EDWARD J III BOHNE,ELIZABETH ELLEN	<b>Adj. Bldg. S.F.:</b> 2206	<b>Email:</b> <a href="mailto:realprop@bcpa.net">realprop@bcpa.net</a>
<b>Mailing Address:</b> 721 CORDOVA RD FORT LAUDERDALE, FL 33316	<b>Bldg Under Air S.F.:</b> 1915	<b>Zoning :</b> RS-8 - RESIDENTIAL SINGLE FAMILY/LOW MEDIUM DENSITY
<b>Physical Address:</b> 721 CORDOVA ROAD FORT LAUDERDALE, 33316-1429	<b>Effective Year:</b> 1953	<b>Abbr. Legal Des.:</b> RIO VISTA ISLES UNIT 3 7-47 B LOT 47 S 33.34 LESS W 2 OF S 20, 48 N 33.33 LESS W 2 BLK 30
	<b>Year Built:</b> 1952	
	<b>Units/Beds/Baths:</b> 1 / 3 / 2	

2020 values are considered "working values" and are subject to change.

**PROPERTY ASSESSMENT**

Year	Land	Building / Improvement	Agricultural Saving	Just / Market Value	Assessed / SOH Value	Tax
2022	\$354,000	\$567,090	0	\$921,090	\$921,090	
2021	\$354,000	\$567,090	0	\$921,090	\$921,090	\$17,653.46
2020	\$354,000	\$534,830	0	\$888,830	\$888,830	\$16,968.09

**EXEMPTIONS AND TAXING AUTHORITY INFORMATION**

	County	School Board	Municipal	Independent
Just Value	\$921,090	\$921,090	\$921,090	\$921,090
Portability	0	0	0	0
Assessed / SOH	\$921,090	\$921,090	\$921,090	\$921,090
Granny Flat				
Homestead	0	0	0	0
Add. Homestead	0	0	0	0
Wid/Vet/Dis	0	0	0	0
Senior	0	0	0	0
Exemption Type	0	0	0	0
Affordable Housing	0	0	0	0
Taxable	\$921,090	\$921,090	\$921,090	\$921,090

**SALES HISTORY FOR THIS PARCEL**

Date	Type	Price	Book/Page or Cin
06/07/2021	Warranty Deed Qualified Sale	\$1,182,000	117332858
03/19/2014	Warranty Deed Qualified Sale	\$950,000	112175499
05/01/1987	Warranty Deed	\$205,000	14442 / 752

**LAND CALCULATIONS**

Unit Price	Units	Type
\$40.00	8,850 SqFt	Square Foot

**RECENT SALES IN THIS SUBDIVISION**

Property ID	Date	Type	Qualified/ Disqualified	Price	CIN	Property Address
504211180660	10/28/2021	Warranty Deed		\$2,433,000	117701375	1108 SE 11 ST FORT LAUDERDALE, FL 33316
504211181670	10/19/2021	Warranty Deed	Qualified Sale	\$1,780,000	117679738	1212 PONCE DE LEON DR FORT LAUDERDALE, FL 33316
504211181610	09/24/2021	Warranty Deed	Qualified Sale	\$1,285,000	117647156	1110 PONCE DE LEON DR FORT LAUDERDALE, FL 33316
504211181130	09/14/2021	Warranty Deed	Qualified New Construction	\$2,499,000	117626270	851 SE 11 CT FORT LAUDERDALE, FL 33316
504211181170	09/13/2021	Warranty Deed	Qualified Sale	\$920,000	117595274	721 SE 11 CT FORT LAUDERDALE, FL 33316

**SPECIAL ASSESSMENTS**

Fire	Garb	Light	Drain	Impr	Safe	Storm	Clean	Misc
Ft Lauderdale Fire-rescue (03) Residential (R) 1						(F1)  1.00		

**SCHOOL**

**Harbordale Elementary:** A  
**Sunrise Middle:** B  
**Fort Lauderdale High:** A

**ELECTED OFFICIALS**

<b>Property Appraiser</b> Marty Kiar	<b>County Comm. District</b> 7	<b>County Comm. Name</b> Tim Ryan	<b>US House Rep. District</b> 22	<b>US House Rep. Name</b> Ted Deutch
<b>Florida House Rep. District</b> 93	<b>Florida House Rep. Name</b> Chip LaMarca	<b>Florida Senator District</b> 34	<b>Florida Senator Name</b> Gary M. Farmer, Jr.	<b>School Board Member</b> Sarah Leonardi

# **SURVEY**

*721 CORDOVA ROAD, FORT LAUDERDALE, FL 33316*

*EDWARD & ELIZBETH BOHNE • 954-444-2234 • TED@ZCONSTRUCTIONINC.COM*

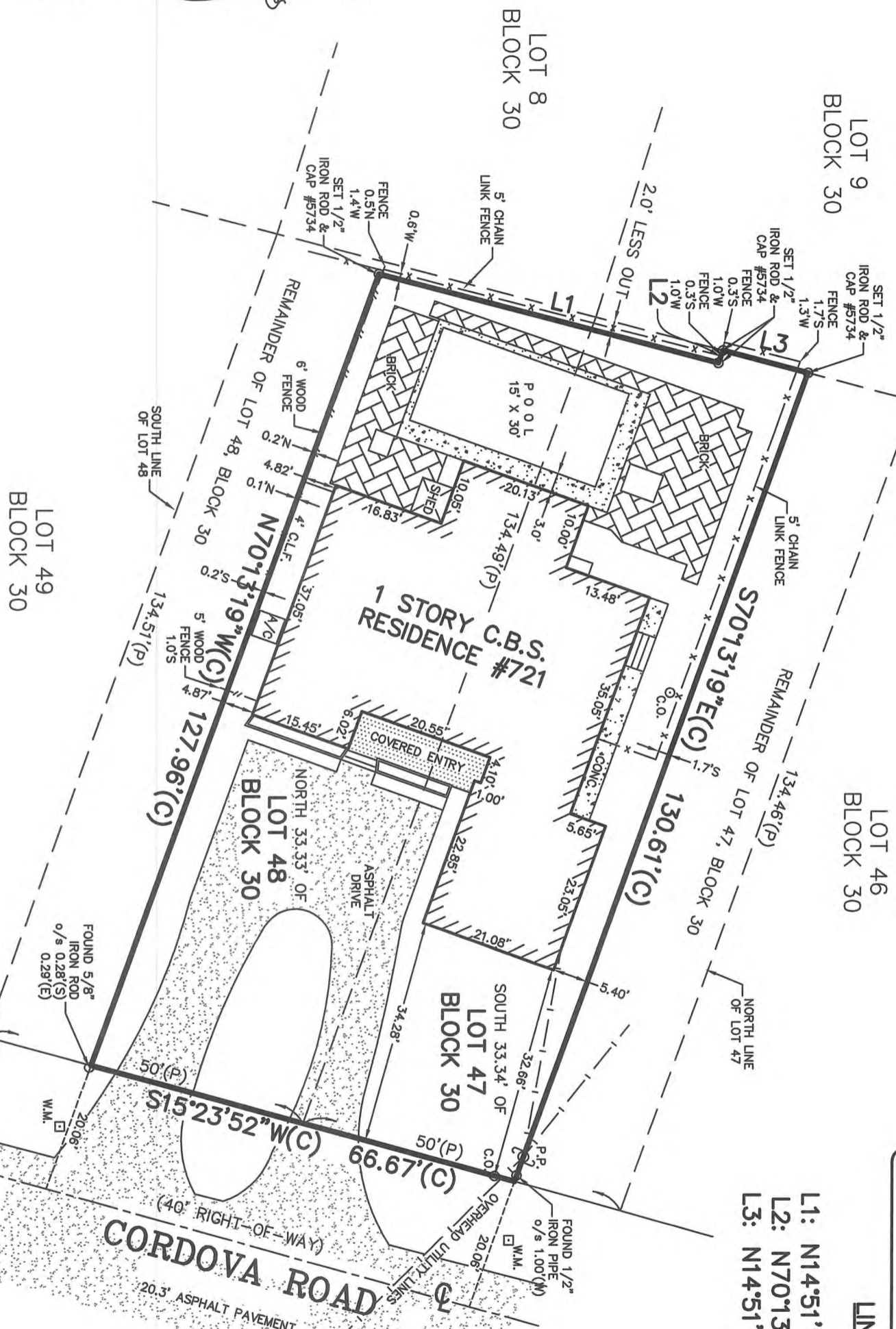

- LINE DATA:**
- L1: N14°51'13"E(C) 53.35'(C)
  - L2: N70°13'19"W(C) 2.01'(C)
  - L3: N14°51'13"E(C) 13.38'(C)

SCALE: 1" = 20'	SKETCH NO.: 21-1142
DRAWN BY: O.D.I.	SIDE 2 OF 2

# SITE PHOTOS

*721 CORDOVA ROAD, FORT LAUDERDALE, FL 33316*

*EDWARD & ELIZBETH BOHNE • 954-444-2234 • TED@ZCONSTRUCTIONINC.COM*



162





# VESSEL INFORMATION

*721 CORDOVA ROAD, FORT LAUDERDALE, FL 33316*

*EDWARD & ELIZBETH BOHNE • 954-444-2234 • TED@ZCONSTRUCTIONINC.COM*



PLEASE RETAIN THIS LETTER ON YOUR VESSEL UNTIL SUCH TIME THE U.S. COAST GUARD ISSUES A CERTIFICATE OF DOCUMENTATION INTO YOUR OWNERSHIP THIS LETTER IS DATED THE 31<sup>ST</sup> OF AUGUST 2021 AND EXPIRES ON THE 31<sup>ST</sup> OF DECEMBER 2021

EDWARD S. BOHNE, III  
721 CORONA ROAD  
FT. LAUDERDALE, FL 33316

RE: 2014 INTREPID 400 CUDDY  
SC-5525-DD / IBW40174A414

This letter is issued as evidence that I am in the process of applying to the National Vessel Documentation Center, U.S. Coast Guard in Falling Waters, WV for issuance of a Certificate of Documentation into your ownership. *The Coast Guard is currently 16-20 weeks behind...if you are taking a trip out of the country please contact my office.*

This letter is not to be considered a substitute for the vessel's Certificate of Documentation but may be taken as evidence that an application has been made for the Certificate of Documentation in the ownership stated above.

You as the owner should be advised that although this vessel is being documented with the U.S. Coast Guard as a vessel of the United States the vessel may be subject to State registration and sales tax. Please contact the appropriate office and pay any fees that are applicable.

If you have any questions regarding the ownership and/or documentation of your vessel please do not hesitate to contact this office.

***FYI...Annual Renewal Fee - One Year Renewal - Effective 11/10/14 the Coast Guard is now charging a fee of \$26 to renew your Certificate of Documentation, (COD). Your COD MUST be renewed each year...your COD will expire one year from the month of issue. Five Year Renewal - Effective 01/01/2018 the Coast Guard is now allowing you to renew your COD for five years.***

Sincerely,  
*Deanna Kolenc*  
Deanna Kolenc

112 PEYTONS RIDGE DRIVE, HUBERT NC 28539  
706-937-6788: OFFICE | 910-939-1517: FACSIMILE | [deanna@vannmaritime.com](mailto:deanna@vannmaritime.com): E

DEPARTMENT OF HOMELAND SECURITY  
U.S. Coast Guard  
BILL OF SALE

OMB No: 1625-0027

Expires: 04/30/2023

1. VESSEL NAME  
40' Intrepid Cuddy

2. OFFICIAL NUMBER OR HULL ID NUMBER  
IBW40174A414

3. NAME(S) AND ADDRESS(ES) OF SELLERS  
The Big Ease LLC  
3985 Blackmoor Street  
Mount Pleasant, SC 29466

3A. TOTAL INTEREST OWNED (IF LESS THAN 100%): 100 %

4. NAME(S) AND ADDRESS(ES) OF BUYER(S) AND INTEREST TRANSFERRED TO EACH  
Edward J. Bohne, III  
721 Cordova Road  
Fort Lauderdale, FL 33316

4A. TOTAL INTEREST TRANSFERRED (100% UNLESS OTHERWISE SPECIFIED): 100 %

4B. MANNER OF OWNERSHIP. UNLESS OTHERWISE STATED HEREIN, THIS BILL OF SALE CREATES A TENANCY IN COMMON, WITH EACH TENANT OWNING AN EQUAL UNDIVIDED INTEREST. CHECK ONLY ONE OF THE FOLLOWING BLOCKS TO SHOW ANOTHER FORM OF OWNERSHIP.

JOINT TENANCY WITH RIGHT OF SURVIVORSHIP       TENANCY BY THE ENTIRETIES       COMMUNITY PROPERTY

OTHER (DESCRIBE)

5. CONSIDERATION RECEIVED (ONE DOLLAR AND OTHER VALUABLE CONSIDERATION UNLESS OTHERWISE STATED)

6. I (WE) DO HEREBY SELL TO THE BUYER(S) NAMED ABOVE, THE RIGHT, TITLE AND INTEREST IDENTIFIED IN BLOCK 4 OF THIS BILL OF SALE, IN THE PROPORTION SPECIFIED HEREIN.

VESSEL IS SOLD FREE AND CLEAR OF ALL LIENS, MORTGAGES, AND OTHER ENCUMBRANCES OF ANY KIND AND NATURE, EXCEPT AS STATED ON THE REVERSE HEREOF. VESSEL IS SOLD TOGETHER WITH AN EQUAL INTEREST IN THE MASTS, BOWSPRIT, SAILS, BOATS, ANCHORS, CABLES, TACKLE, FURNITURE, AND ALL OTHER NECESSARIES THERETO APPERTAINING AND BELONGING, EXCEPT AS STATED ON THE REVERSE HEREOF.

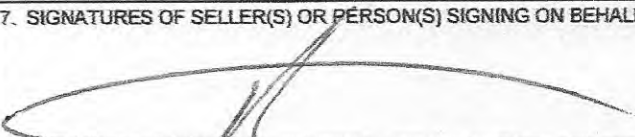
7. SIGNATURES OF SELLER(S) OR PERSON(S) SIGNING ON BEHALF OF SELLER(S).  

8. DATE SIGNED  
7/9/21

9. NAME(S) OF PERSON(S) SIGNING ABOVE, AND LEGAL CAPACITY IN WHICH SIGNED (E.G., OWNER, AGENT, TRUSTEE, EXECUTOR)  
Charles E. Biggie, Managing Member

10. ACKNOWLEDGMENT (TO BE COMPLETED BY NOTARY PUBLIC OR OTHER OFFICIAL AUTHORIZED BY A LAW OF A STATE OR THE UNITED STATES TO TAKE OATH.)

ON 7/9/21 THE PERSON(S) NAMED IN SECTION 9 STATE: FLA  
(DATE)  
ABOVE ACKNOWLEDGED EXECUTION OF THE FOREGOING INSTRUMENT COUNTY: Broward  
IN THEIR STATED CAPACITY(IES) FOR THE PURPOSE THEREIN CONTAINED.

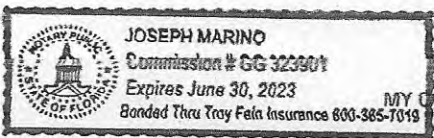

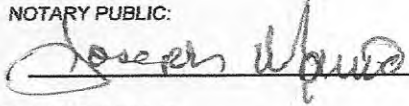
NOTARY PUBLIC:  
  
MY COMMISSION EXPIRES: \_\_\_\_\_ (DATE)

# PROJECT PLANS & ENGINEERING

*721 CORDOVA ROAD, FORT LAUDERDALE, FL 33316*

*EDWARD & ELIZBETH BOHNE • 954-444-2234 • TED@ZCONSTRUCTIONINC.COM*

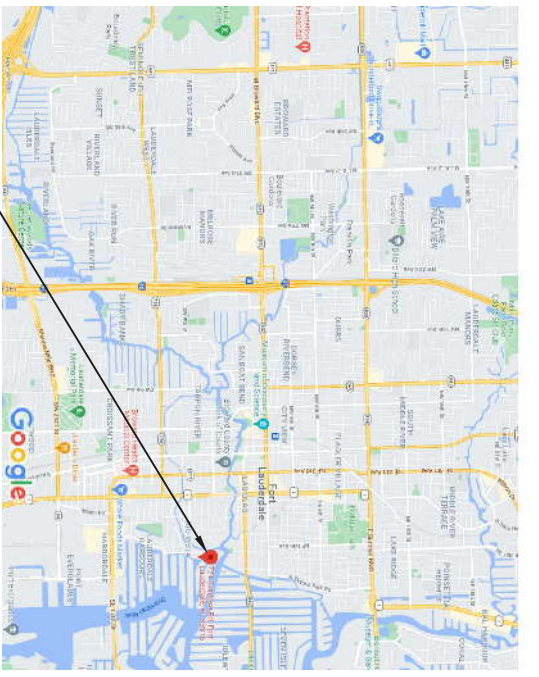

PROJECT LOCATION

LOCATION MAP

PROJECT SITE



AERIAL

**MGR PROFESSIONAL ENGINEERING, INC.**  
 OFFICE: (561) 863-3393  
 CERTIFICATE OF AUTHORIZATION #09967  
 STATE OF FLORIDA  
 MICHAEL BARBER, P.E. #52575

DOCK AND BOAT LIFT

TED BOHNE  
 721 CORDOVA ROAD  
 FORT LAUDERDALE, FL 33316

YACHT LIFTERS, INC.  
 MARINE CONSTRUCTION  
 1126 S FEDERAL HIGHWAY, SUITE 150  
 FORT LAUDERDALE, FL 33316

DATE	REVISIONS	SHEET 1 OF 5
10/11/21	INITIAL DRAWINGS COMPLETED	

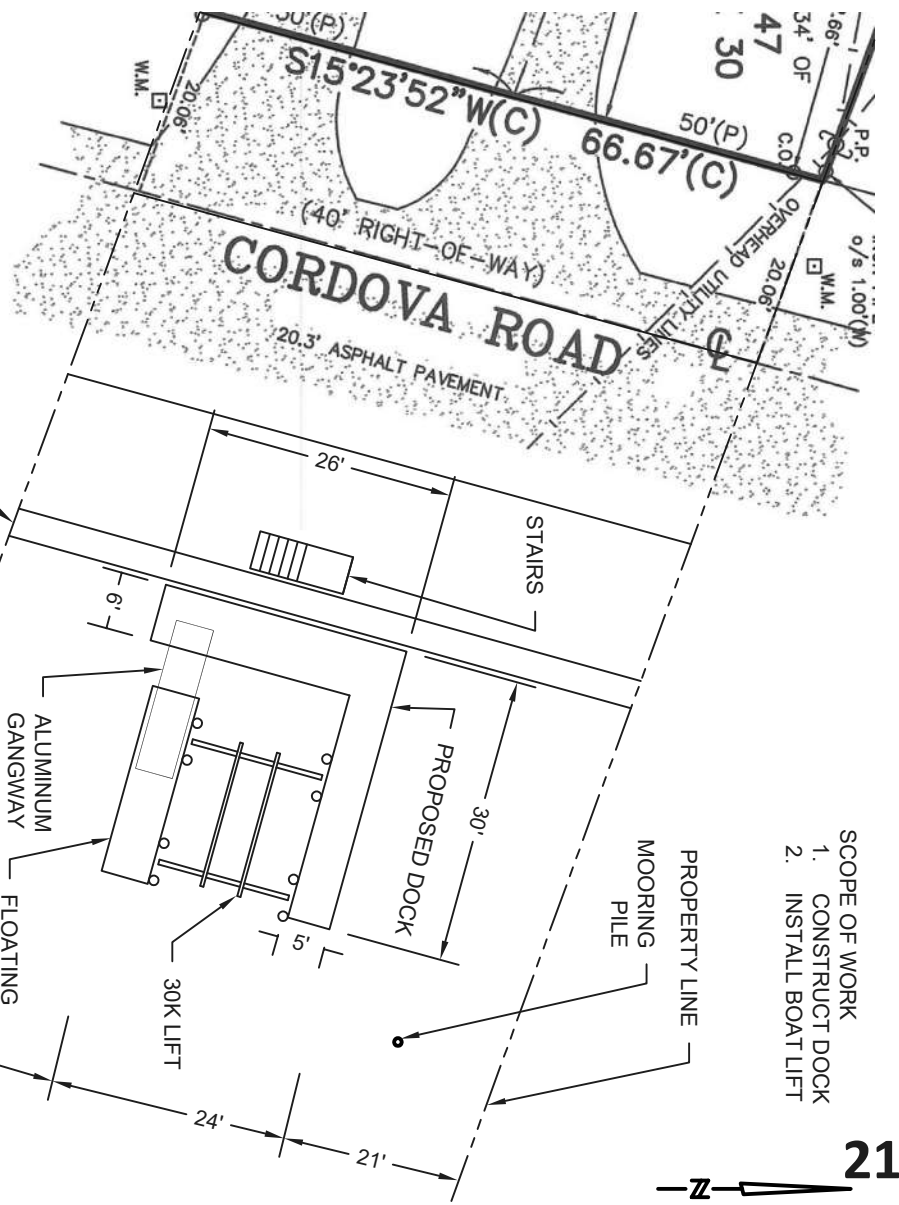

**NOTES:**

LIFT PILES (8) TO BE INCORPORATED WITH THE 5' x 20' FLOATING DOCK AND THE 5' x 24" FINGER PIER.

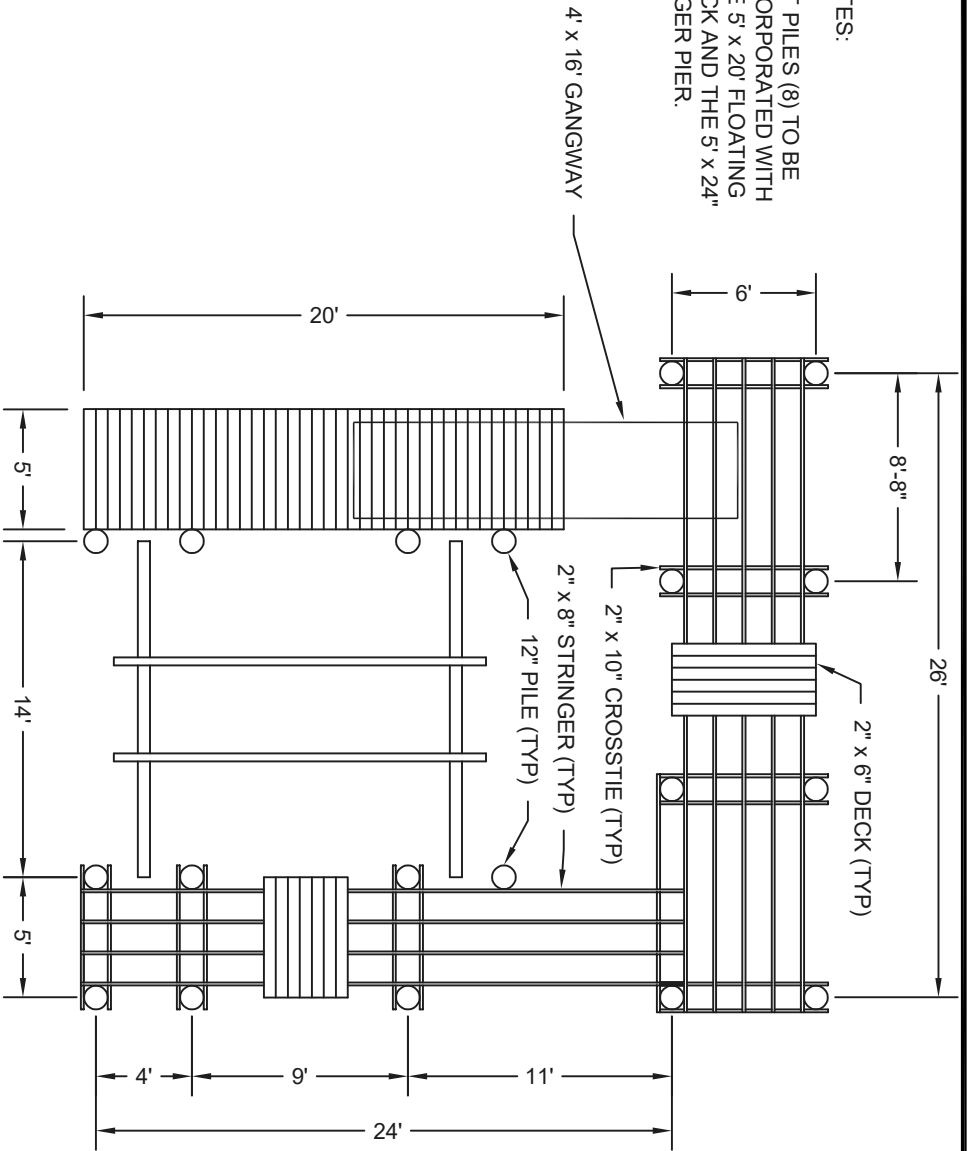

**FRAMING PLAN**  
1/8" = 1'-0"

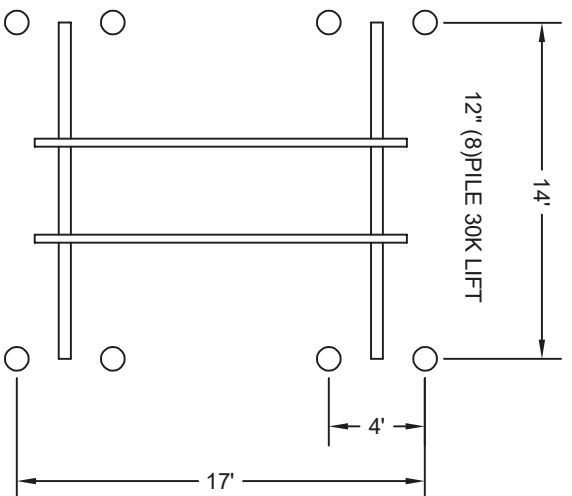

**NOTES:**

1. DECKING - COMPOSITE. SPACE STRINGERS IN ACCORDANCE TO MANUF. REQUIREMENTS.
2. FRAMING: BE 2"x8" STRINGERS, 2"x10" CROSS TIES, PT WOOD.
3. DECK FASTENERS TO BE 16d STAINLESS STEEL RING SHANK NAILS OR 3/4" HEX DRIVEN DECK SCREWS. (OR PER MANUFACT.)
4. ALL FRAMING HARDWARE TO BE STAINLESS STEEL.
5. NEW 12" DIA WOOD PILES - WRAPPED IN PERMA PVC.
6. LUMBER TO BE PRESSURE TREATED FOR MARINE ENVIRONMENT. (ACQ OR CCA)  
0.4 LBS/CF (FRAMING LUMBER)  
2.5 LBS/CF (PILES)
7. LUMBER TO BE #1 QUALITY SOUTHERN YELLOW PINE.

**MGR PROFESSIONAL ENGINEERING, INC.**  
 OF: (561)863-3393  
 CERTIFICATE OF AUTHORIZATION # 09967  
 STATE OF FLORIDA  
 MICHAEL BARBER, P.E. # 52675

**DOCK AND BOAT LIFT**  
 TED BOHNE  
 721 CORDOVA ROAD  
 FORT LAUDERDALE, FL 33316  
 YACHT LIFTERS, INC.  
 MARINE CONSTRUCTION  
 1126 S FEDERAL HIGHWAY, SUITE 150  
 FORT LAUDERDALE, FL 33316

DATE	REVISIONS	INITIAL DRAWINGS COMPLETED	SHEET 2 OF 5
10/11/21			





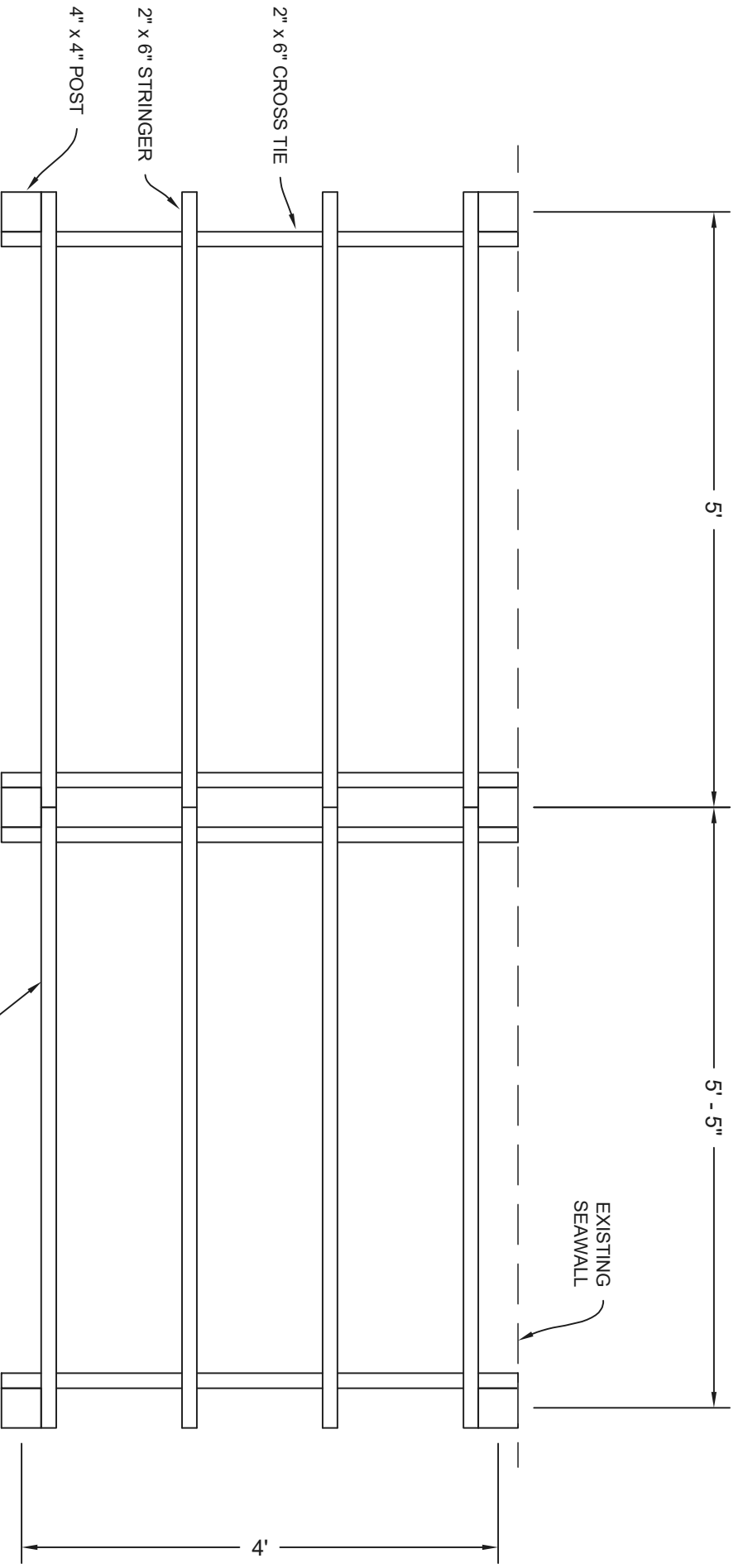

**FRAMING**  
3/4" = 1'-0"

**MGR PROFESSIONAL ENGINEERING, INC.**  
 OF: (561) 863-3393  
 CERTIFICATE OF AUTHORIZATION # 09967  
 STATE OF FLORIDA  
 MICHAEL BARBER, P.E. # 52575

**DOCK AND BOAT LIFT**

TED BOHNE  
 721 CORDOVA ROAD  
 FORT LAUDERDALE, FL 33316

YACHT LIFTERS, INC.  
 MARINE CONSTRUCTION  
 1126 S FEDERAL HIGHWAY, SUITE 150  
 FORT LAUDERDALE, FL 33316

DATE	REVISIONS
10/11/21	INITIAL DRAWINGS COMPLETED



# Direct Drive 8-Post Yacht Lifts



- All Aluminum and Stainless Steel Construction
- Direct Drive with Industrial Duty Stainless Steel Motors
- Massive, Solid Aluminum Grooved Winders with Exclusive SEArmor Corrosion Resistant Coating
- Heavy Duty, Easily Adjustable Guide Poles
- Solid Aluminum Bearing Blocks with Delrin Bearings
- Welded Construction (not bolted)
- Stainless Steel Cables
- Self-Adjusting Cable Keepers
- Wireless Remote Control and Limit Switch
- Optional Electrical Controls with Multiple Switches
- 10 Year Limited Warranty

\*\*\*See our "Complete list of Other Accessories"

## Specifications

Size	Top Carrier Dimensions	Lifter Beam Dimensions	Horse Power	Volt and Amperage	Cable Size	Winders/ Drive Shaft	Vertical Travel	Bunks	Pile Size
30,000 lb. (w/remote)	6" Channel	12" x 16' I-Beam	(4) 1 HP Stainless Steel Motors	240V/30A	3/8" Stainless Steel	Mil-Spec Hardened Grooved Winders	12'	3" x 12" x 20'	(8) 10" Driven Piling
40,000 lb. (w/remote)	Twin I-Beam	Double I-Beam 16' – 20'	Neptune® Patented 1HP Stainless Steel Magnetic Brake Motors	240V/30A	3/8" Stainless Steel	Mil-Spec Hardened Solid Grooved Winders	12'	5" x 12" x 20'	(8) 10" – 12" Driven Piling
50,000 lb. (w/remote)	Twin I-Beam	Double I-Beam 16' – 20'	Neptune® Patented 2HP Stainless Steel Magnetic Brake Motors	240V/60A	7/16" Stainless Steel	Mil-Spec Hardened Solid Grooved Winders	12'	5" x 12" x 20'	(8) 10" – 12" Driven Piling
60,000 lb. (w/remote)	Twin I-Beam	Double I-Beam 12" 18' – 20'	Neptune® Patented 2HP Stainless Steel Magnetic Brake Motors	240V/60A	7/16" Stainless Steel	Mil-Spec Hardened Solid Grooved Winders	12'	5" x 12" x 20'	(8) 12" Driven Piling
70,000 lb. (w/remote)	Twin I-Beam	Triple I-Beam 12" Double Lifters 18' – 21'	Neptune® Patented 2HP Stainless Steel Magnetic Brake Motors	240V/60A	7/16" Stainless Steel	Mil-Spec Hardened Solid Grooved Winders	12'	5" x 12" x 20'	(8) 12" Driven Piling
80,000 lb (w/remote)	Twin I-Beam	Triple I-Beam 12" Double Lifters 20' – 21'	Neptune® Patented 2HP Stainless Steel Magnetic Brake Motors	240V/60A	7/16" Stainless Steel	Mil-Spec Hardened Solid Grooved Winders	12'	8" x 12" x 20'	(8) 12" Concrete Driven Piling
120,000 lb (w/remote)	Twin I-Beam	Double I-Beam 18" Quad Lifters 20' – 22'	Neptune® Patented 2HP Stainless Steel Magnetic Brake Motors	240V/80A	7/16" Stainless Steel	Mil-Spec Hardened Solid Grooved Winders	12'	8" x 12" x 20'	(8) 12" Concrete Driven Piling
180,000 lb (w/remote)	Twin I-Beam	Double I-Beam 18" Quad Lifters 20' – 22'	Neptune® Patented 2HP Stainless Steel Magnetic Brake Motors	240V/80A	7/16" Stainless Steel	Mil-Spec Hardened Solid Grooved Winders	12'	8" x 12" x 20'	(8) 12" Concrete Driven Piling

# LANDSCAPING PLAN

*721 CORDOVA ROAD, FORT LAUDERDALE, FL 33316*

*EDWARD & ELIZBETH BOHNE • 954-444-2234 • TED@ZCONSTRUCTIONINC.COM*

NORTH

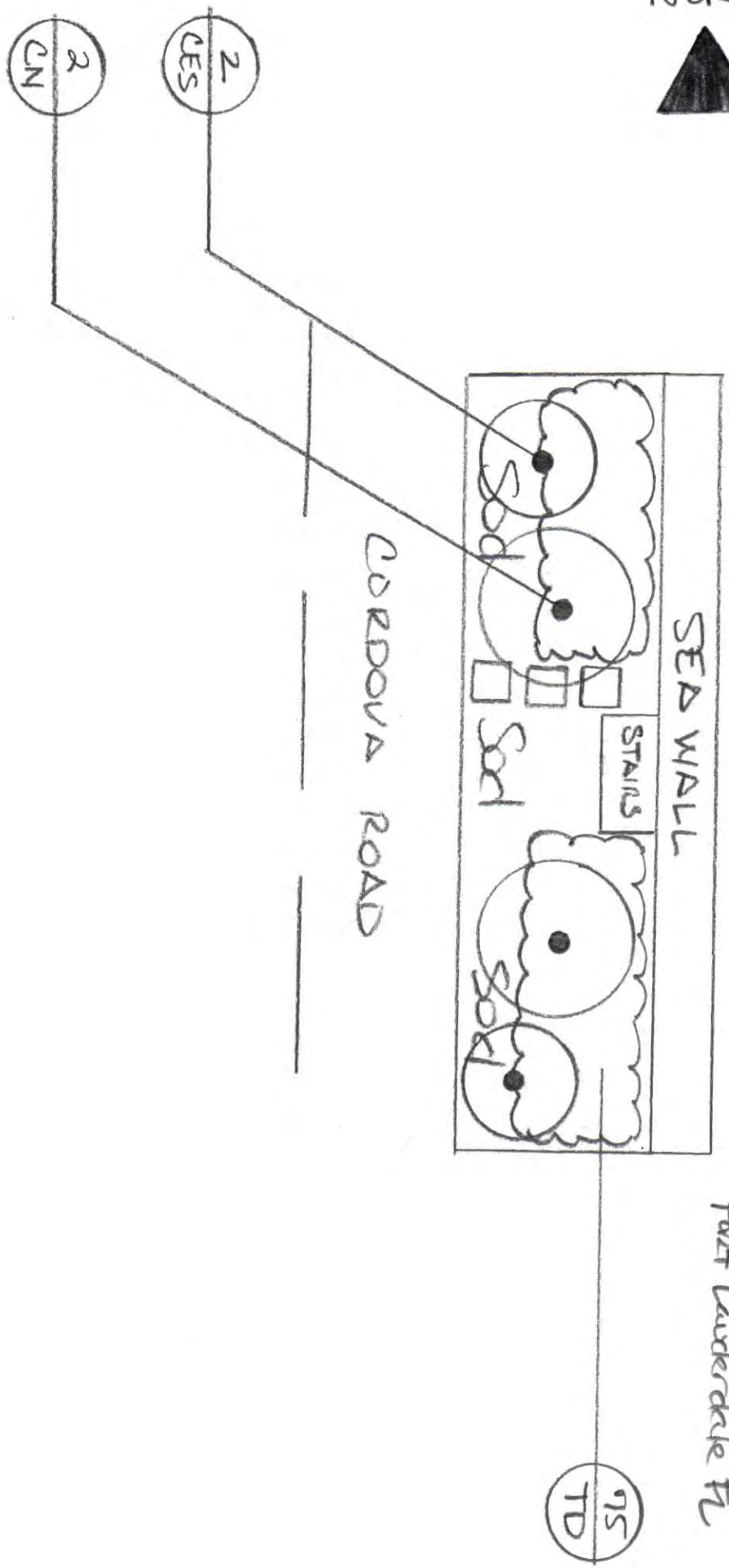

Robus Residence  
 721 Cordova Road  
 Fort Lauderdale FL

PLANT LIST

- CONOCARPUS erectus SERICEUS / Silverbuttonwood 18-14' DA 2 1/2" CAL
- CN Cocos nucifera "Green Malayan 8' GW
- TD Tripsacum dactyloides / Fakahatchee grass
- SOD Floerstonia or Bahia

SCALE  
 1/8" = 1'

# EXHIBIT A

*721 CORDOVA ROAD, FORT LAUDERDALE, FL 33316*

*EDWARD & ELIZBETH BOHNE • 954-444-2234 • TED@ZCONSTRUCTIONINC.COM*

# EXHIBIT A 721 CORDOVA ROAD

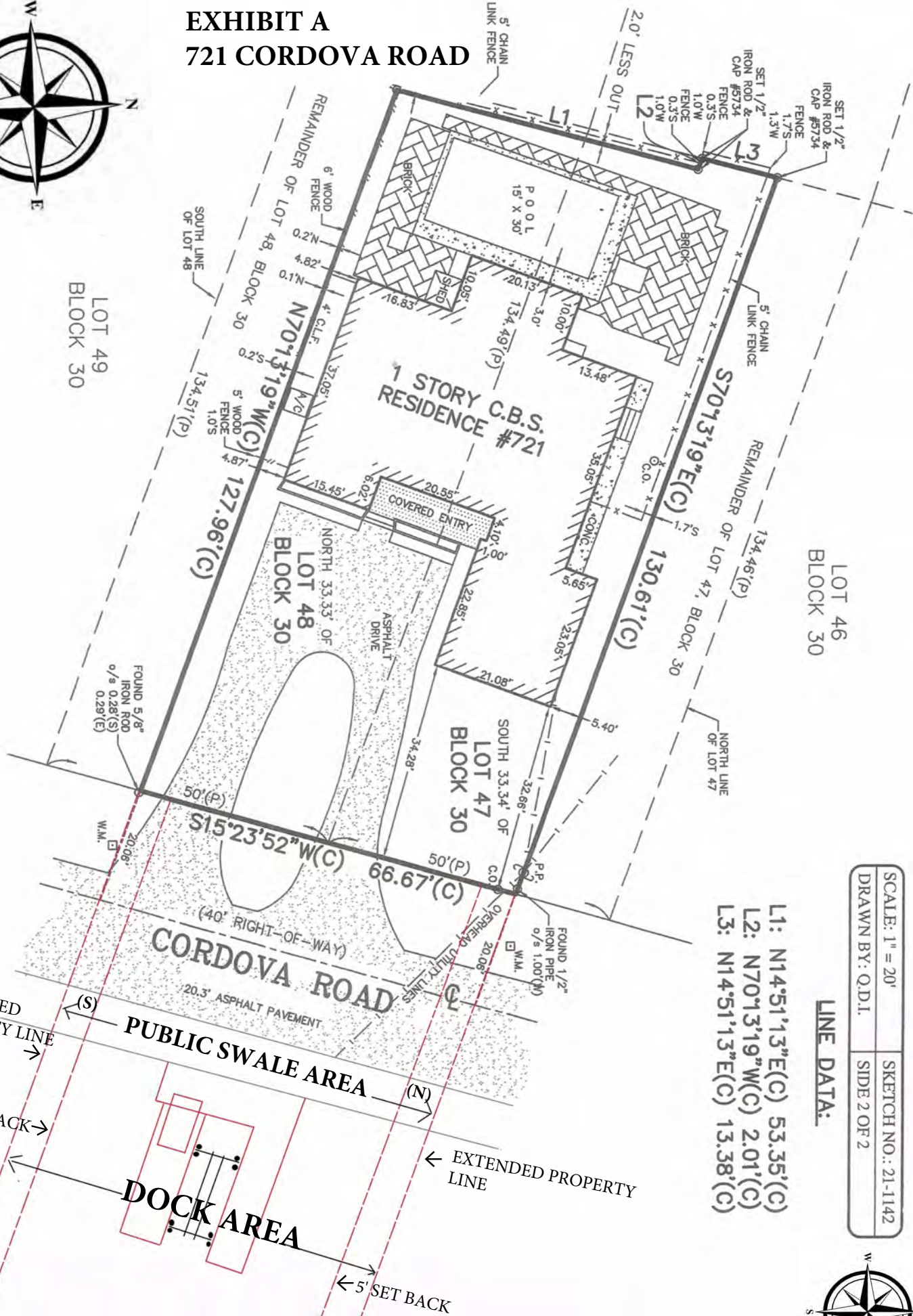

- LINE DATA:**
- L1: N14.51'13"E(C) 53.35'(C)
  - L2: N70°13'19"W(C) 2.01'(C)
  - L3: N14.51'13"E(C) 13.38'(C)

SCALE: 1" = 20'	SKETCH NO.: 21-1142
DRAWN BY: Q.D.I.	SIDE 2 OF 2



# AERIAL PHOTOGRAPH

*721 CORDOVA ROAD, FORT LAUDERDALE, FL 33316*

*EDWARD & ELIZBETH BOHNE • 954-444-2234 • TED@ZCONSTRUCTIONINC.COM*

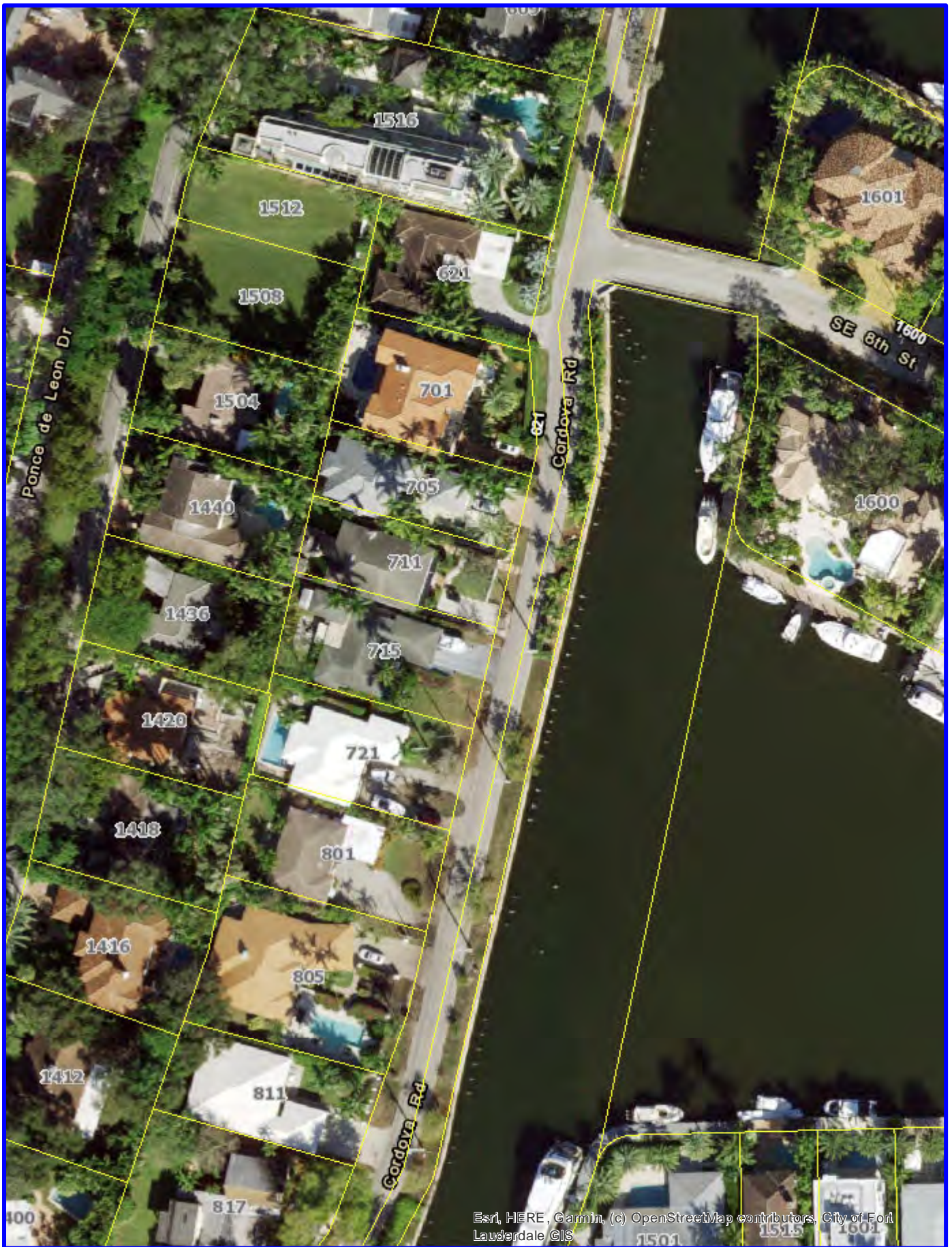

Esri, HERE, Garmin, (c) OpenStreetMap contributors, City of Fort Lauderdale GIS



CITY OF FORT LAUDERDALE

721 Cordova Rd.

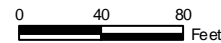

**GIS**  
Fort Lauderdale

Sec. 8-144. - Private use of public property abutting waterways.

The city commission, by resolution duly adopted, may grant a dock permit for the use by private persons of certain public property abutting or touching a waterway, including some public property described in section 8-143 as set forth herein, except: (i) areas being utilized as municipal docks for which docking fees are being charged and collected and those areas under license by the city; (ii) street ends as more particularly defined herein; (iii) city parks; (iv) subject to certain conditions set forth in subsection (17) hereof. Upland parcels with property lines that abut or are contiguous to a navigable waterway independent of that described in section 8-143(a), and (v), certain upland parcels falling within the ambit of the Florida Supreme Court case of *Burkart v. City of Fort Lauderdale*, 168 So. 2d 65 (Fla. 1964) and more particularly defined below in subsection (18) hereof, said dock permits may be granted under the following conditions and restrictions, to-wit:

- (1) Application for a dock permit under this section shall be accompanied by an administrative fee, the amount of which shall be reflective of the cost of administering the application, review and adoption of resolution granting a permit for the use by private persons of public property abutting or touching a waterway and shall be established from time to time by the city commission by duly adopted resolution. As to upland parcels, the application shall also be accompanied by a survey of the upland parcel and adjacent waterway qualifying for the dock permit with the side property lines and side yard setback lines extended into the abutting waterway. The application shall further be accompanied by a sketch and description illustrating the specific location and dimensions of the dock area and public swale area, as more particularly defined below, to be reviewed and recommended for approval to the city commission. An application for a dock permit may be filed by contract vendee prior to obtaining fee simple title to the upland parcel, provided, however, the granting of a dock permit will not be effective until such time as the conveyance of fee simple title of the upland parcel to the applicant has been recorded in the Public Records of Broward County, Florida.
  - (a) Ten (10) days prior to adoption of the resolution granting a dock permit, the applicant shall: (i) execute a covenant running with the land, in a form and content acceptable to the city attorney, binding the obligation of maintenance, repair, and reconstruction and timely removal of the dock and appurtenant seawall to the applicant/permit holder and qualifying upland parcel and providing for a claim of lien to be recorded against the qualifying upland parcel for costs expended by the city in maintaining, repairing, or reconstructing the permitted dock upon the failure permit holder's obligations relative thereto and removal of the permitted dock upon failure of the dock permit holder to remove the dock within the time specified in subsection 4(c) hereof, which such covenant shall be recorded by the city in the Public Records of Broward County, Florida, at the permit holder's

expense. In the event a claim of lien is recorded against the upland parcel and the city is thereafter reimbursed for the costs underlying the claim of lien, the city shall record a release, discharge or satisfaction of the claim of lien. In the event the dock and all appurtenances are timely removed, the covenant running with the land shall be released and discharged by the city, executed by the city manager or deputy city manager and such release or discharge shall be recorded by the city in the Public Records of Broward County, Florida, at the expense of the permit holder.

- (2) The dock permit granted herein shall not be effective until such time as: (i) a certified copy of the resolution granting the dock permit has been recorded in the Public Records of Broward County, Florida by the city at the expense of the applicant/permit holder; (ii) together with a recorded copy of the covenant running with the land as referenced in subsection 1(a) above; and (iii) a copy of the recorded resolution and covenant running with the land is filed with the city's office of marine facilities. In order to optimize and preserve the existing character of the surrounding neighborhood, applicants for a permit under this section are limited to owners of upland parcels as hereinafter defined.
  - (a) An "upland parcel" is a parcel of land that by extending the side property lines thereof to perpendicularly intersect with the boundary lines of the adjacent waterway defined in section 8-143, where the upland parcel lies directly across the street from the public property abutting or touching a waterway identified in city code section 8-143, for which one may qualify for applying for a dock permit ("Public Dock Permit Parcel"). To qualify as an upland parcel, a principal building must be situated thereon. The owner(s) of the upland parcel, including contract vendees thereof, shall be the only person(s) eligible to apply for a dock permit for the public dock permit parcel across the street from the upland parcel.
  - (b) For a public dock permit parcel for an upland parcel where there is a curvature to the boundaries of the waterway, the office of marine facilities shall make recommendations to the marine advisory board with respect to criteria: (i) the length of the dock; (ii) the size and dimensions of the envelope within which a vessel may be berthed; (iii) dock area and public swale area as defined below. In its review, the marine advisory board shall make recommendations to the city commission as to: (i), (ii) and (iii) above, as well as other relevant terms and conditions. Applicants for a dock permit under this subsection 2(b) shall be limited to owners of upland parcels for which side property lines intersect in a non-perpendicular manner with the boundary lines of the adjacent waterway as defined in section 8-143.
- (3) To allow the general public's access to the waterway abutting the public dock permit

parcel, the permitted length of a marginal permitted dock shall not exceed the width of the corresponding upland parcel as measured from the extension into the waterway of the side yard setbacks for the principal building on the upland parcel. The permitted length of a marginal permitted dock under subsection 2(b) above shall be determined by the city commission upon review of the marine advisory board recommendations. No vessel may be berthed in such a manner that it encroaches into the area proscribed under section 47-19.3(h). The permitted berthing envelope for a vessel shall be determined by the city commission upon review of the marine advisory board recommendations for public dock permit parcels described in subsection 2(b) above. The berthing of a vessel in such a manner that encroaches into the area proscribed under section 47-19.3(h) or exceeds the permitted berthing envelope as determined by the city commission for public dock permit parcels described in section 2(b) hereof shall be unlawful and a violation of this Code as set forth in section 1-6.

- (4) (a) During the term of the dock permit, the permit holder shall be required to repair, replace, reconstruct or maintain the dock or adjacent seawall or both to meet the requirements of section 47-19.3(f). "Boat slips, docks, boat davits, hoists and similar mooring structures" of the city's Unified Land Development Code and other relevant terms and conditions imposed by the resolution granting the dock permit. Permit holder shall also be required, during the term of the dock permit, to post and maintain a city-issued sign on the dock indicating the Resolution No. that authorized the permit to use the dock.
- (b) The permit to use the dock shall expire upon the: (i) abandonment of the use of the dock; or (ii) recordation of the deed of conveyance transferring title to the upland parcel; or (iii) termination, expiration or revocation of the dock permit by the city commission, whichever (i), (ii) or (iii) shall first occur, subject to survivability of the obligation to remove the dock pursuant to subsection 4(c) below and the obligations within the covenant running with the land as set forth in subsection 1(a) hereof.
- (c) Except as set forth in subsection 4(e)(d) below, upon expiration of the permit to use the dock, the permit holder shall be obligated to remove the dock and all appurtenances thereto no later than three (3) months after the termination, revocation or expiration of the permit to use the dock. This provision shall be a continuing obligation that survives expiration of the permit to use the dock.
- (d) In the event a dock permit is granted to a successor applicant for the same public dock permit parcel within the time proscribed in subsection 4(d) hereof, the obligation to remove the dock and all appurtenances thereto shall be discharged as to the former permit holder and a release and discharge of the covenant

running with the upland parcel shall be executed by the city manager or deputy city manager and recorded by the city in the Public Records of Broward County, Florida at the expense of the permit holder.

- (e) The dock permit granted may be revoked by the city commission for good cause shown upon at least ninety (90) days advance notice to the permit holder and an opportunity for the permit holder to be heard.
- (5) All improvements such as docks, seawalls and the like which are made or placed upon the public dock permit parcel or within the dock area and public swale area by a private person shall be constructed with appropriate permits from all applicable regulatory authorities having subject matter jurisdiction regarding such matters. All maintenance and repairs shall be performed according to city engineering standards and all applicable regulatory codes including the city's Unified Land Development Code regulations, Florida Building Code and Broward County Amendments thereto.
- (6) All docks installed pursuant to this section must be either: (i) floating docks that can adapt to sea level rise over their useful life span; or (ii) fixed docks installed at a minimum elevation consistent with the requirements of section 47-19.3(f); or (iii) fixed docks the height of which are even with the city's seawall, whichever (ii) or (iii) is the greater. Penetrating the city seawall to support the dock or permanently attaching improvements, such as cleats, ladders, ramps, mooring whips or similar devices to the city's seawall is prohibited, unless: (a) specifically recommended pursuant to the dock building permit review process; or (b) where the seawall and dock are being constructed by the dock permit holder; or (c) upon demonstration of hardship, as it relates to accommodations under the Americans with Disability Act, as same may be amended from time to time and as authorized in the resolution granting the dock permit.
- (7) The holder of the permit shall be responsible for maintaining improvements within the dock area, as hereinafter defined and for maintaining and beautifying the public swale area, as hereinafter defined. The public swale area shall be landscaped in accordance with: (i) the established landscape plan for the area in question adopted by the department of sustainable development; or (ii) a landscape plan approved by the department of sustainable development and embodied in the resolution adopted by the city commission granting the permit under this section. Failure to do so shall be grounds for revocation of the permit.
  - (a) For the purposes of this section, the term "dock area" shall mean that area bounded by: (i) the upland cap of the seawall abutting the dock; and (ii) extending over the water the length and width of the dock; and (iii) including the area within which the vessel may be berthed and all appurtenances to the dock area. The length of the dock shall not exceed: (1) the distance between the extension into the waterway of the two (2) side yard setbacks for the principal building on the

corresponding upland parcel; nor (2) the boundaries of the dock as set by the city commission pursuant to subsection 2(b) above, whichever (1) or (2) above is applicable.

- (b) For the purposes of this section, the term "public swale area" shall be the area: (1) within the waterward extension of the side property lines of the upland parcel from the edge of the adjacent publicly dedicated right-of-way closest to the waterway to the wet-faced edge of the seawall cap, excluding therefrom the dock; or (2) the boundaries of the dock as set by the city commission pursuant to subsection 2(b) above, whichever (1) or (2) above is applicable.
- (8) Parking in the public swale area, where allowed, is intended to be temporary in nature. Overnight or long-term parking by persons associated with upland property owners under subsection 2(a) or (b) hereof both with and without a dock permit is discouraged. There shall be no fueling of vessels from tank trucks along the adjacent publicly dedicated right-of-way.
- (9) The holder of such dock permit shall not charge or collect any rent or fees from anyone using such dock constructed on the public dock permit parcel. Signage such as "private dock" may be placed on the dock within the dock area. No signage shall be placed upon or within the public swale area. Only vessels owned by the permit holder and registered with the city as part of the dock permit application or amended thereafter may be moored at the permitted dock. Except as to a tender, there shall be no rafting of vessels from the vessel moored at the permitted dock. The berthing of a vessel at a public dock permit parcel that is not authorized pursuant to the city commission granting a dock permit ("Unauthorized Vessel") shall be unlawful and a violation of the Code pursuant to section 1-6.
- (10) A permit granted to a permit holder to construct a dock or authorization to use an existing dock upon the public dock permit parcel and the acceptance and use of same by the permit holder shall constitute a guarantee from the permit holder to the city to indemnify and hold the city harmless for any damage or injury to any person using such facilities.
- (11) The public swale area shall be kept open at all times as means of reasonable ingress and egress to the public, but the permit holder shall have the right to exclude the public from the dock area.
- (12) The violation of any provisions of this section or any regulations relating thereto hereinafter enacted or violations of any of the terms or conditions relative to the granting or renewal of a dock permit shall be unlawful and a violation of this Code pursuant to section 1-6 and may also constitute cause for revocation of the permit.
- (13) The resolution granting the permit or the administrative approval of the permit for a renewal term may specify additional reasonable terms and conditions pertaining to the

use or improvement of the public dock permit parcel.

- (14) Only public lands which are not needed by the city for public docking purposes are available for private use under the terms hereof, and the supervisor of marine facilities shall furnish to the city manager a complete list of all street-ends and other city-owned property abutting waterways which is not needed for dockage purposes from time to time, provided, however, no dock permits shall be issued under subsection (15), (16), (17), and (18), except in compliance with the terms and conditions thereof.
- (15) No dock permits shall be issued for public dock permit parcels where the public right-of-way terminates at the waterway (e.g. "street ends"). For dock permits that were issued for street-ends prior to June 1, 2019, those dock permits shall continue to remain valid, until expiration of their initial term, and, upon renewal such dock permit shall be subject to the terms and conditions set forth in any renewal permits and this section, other than the prohibition against issuance of dock permits for street-ends.
- (16) To preserve the general public's right to intermittently use and have access to city parks located on waterways, no dock permits shall be issued for parcels where the public right-of-way is located within city-owned land that is used for park purposes. For dock permits that were issued for city-owned land that was used for park purposes at the time of issuance, those dock permits shall continue to remain valid, until expiration of their initial term, and, upon renewal such dock permit shall be subject to the terms and conditions set forth in any renewal permits and in this section, other than the prohibition against issuance of dock permits along public rights-of-way within city-owned lands used for park purposes.
- (17) Other than upland parcels referenced in subsection (18) below, subject to exceptions hereinafter set forth, no dock permits shall be issued for upland parcels that abut and are contiguous to a waterway and have riparian rights relative thereto after July 1, 2025 or after such date that the city raises the seawall with municipal funds, whichever is first. For dock permits that were issued prior to June 1, 2019 for upland parcels that abutted and are contiguous to a waterway and to which riparian rights have attached thereto, those dock permits shall continue to remain valid until expiration of their initial term, and, upon renewal such dock permit shall be subject to the terms and conditions set forth in any renewal permits and this section, other than the prohibition against issuance of dock permits for upland parcels that abut a waterway and have riparian rights. Any permits for these upland parcels issued after June 1, 2019 will require the raising of the seawall by the applicant to the current elevation standard as a condition of the dock permit.
- (18) In accordance with the Florida Supreme Court holding in *Burkart v. City of Fort Lauderdale*, 168 So. 2d 65 (Fla. 1964), dock permits shall not be required for the following lots and blocks set forth on the Plat of IDLEWYLD, as recorded in Plat Book 1,

Page 19 of the Public Records of Broward County, Florida: Lots 1—5 and 11—12 Block 1; Lots 1—6 Blocks 2, 3, 4, 5, 6, and 8; Lots 1-7, Block 8: and Lots 1—3 and 27—32, Block 12 thereof.

(Code 1953, § 11-12; Ord. No. C-68-23, § 2, 6-4-68; Ord. No. C-87-95, § 1, 11-17-87; Ord. No. C-17-28, § 20, 9-13-17; Ord. No. C-19-22, § 1, 10-2-19)

# ITEM VI

## MEMORANDUM MF NO. 21-31

DATE: November 23, 2021  
TO: Marine Advisory Board Members  
FROM: Andrew Cuba, Marine Facilities Manager  
RE: December 2, 2021 MAB Meeting - Dock Waiver of Distance Limitations – Edward & Elizabeth Bohne / 721 Cordova Road

Attached for your review is an application from Edward and Elizabeth Bohne, 721 Cordova Road.

### APPLICATION AND BACKGROUND INFORMATION

The applicant is requesting approval for installation of an L-shaped fixed wood dock, a 20' x 5' floating dock, access gangway, a 30,000 pound boat lift and seawall access stairs extending a maximum of +/- 30 ' from the wet face of the seawall into adjacent Lake Juanita. The distances these structures extend from the property line into the waterway are shown in the survey and summarized in Table 1 below:

**TABLE 1**

<b>PROPOSED STRUCTURES</b>	<b>STRUCTURE DISTANCE FROM PROPERTY LINE</b>	<b>PERMITTED DISTANCE WITHOUT WAIVER</b>	<b>AMOUNT OF DISTANCE REQUIRING WAIVER</b>
<b>L-Shaped Fixed Dock</b>	<b>+/-30'</b>	<b>25'</b>	<b>+/-5'</b>
<b>Floating Dock</b>	<b>+/-30'</b>	<b>25'</b>	<b>+/-5'</b>
<b>Boat Lift</b>	<b>+/-30'</b>	<b>25'</b>	<b>+/-5'</b>

The City's Unified Land and Development Regulations (UDLR) Sec. 47-19.3.C limits the maximum distance of mooring structures, including boat lifts, to 25' or 25% of the width of the waterway, whichever is less. Section 47-19.3.E authorizes the City Commission to waive that limitation based on a finding of extraordinary circumstances. The applicant indicates that the proposed structures are necessary for safely mooring resident's vessels, especially during extreme weather. In addition, the extra 5' of water depth will allow for vessel storage protecting both the motors and aquatic resources. The issuance of this Dock Waiver is contingent upon approval of a separate Dock Permit for Private Usage of Public Property via City Code 8-144.

### PROPERTY LOCATION AND ZONING

The property is located within the RS-8 Residential Low Medium Density District. It is situated on the western shore of Lake Juanita, a wide waterway with a direct connection to the Intercoastal Waterway (ICWW) via the Rio Valencia Canal.

RECOMMENDATIONS

Should the Marine Advisory recommend approval of the application, the Resolution under consideration by the City Commission should include at least the following as prescribed in the ULDR and City Code of Ordinances:

1. The applicant is required to comply with all applicable building and zoning regulations as well as any other Federal and State laws and permitting requirements including the Broward County Environmental Protection and Growth Management Department, the Florida Department of Environmental Protection and the U.S. Army Corps of Engineers.
2. As a general condition of approval and in order to review for final consistency with construction of facilities in accord with this application and City building permits the applicant is required to provide the City's Supervisor of Marine Facilities with copies of "As Built" drawings from a certified and licensed contractor.
3. The applicant is required to install and affix reflector tape to the proposed boat lift guide poles, if installed, in accord with Section 47.19.3.E of the Unified Land and Development Regulations (ULDR).

AC

Attachment

cc:

Enrique Sanchez, Deputy Director of Parks and Recreation

Jonathan Luscomb, Marine Facilities Supervisor

# **APPLICATION FOR WATERWAY WAIVER**

**EDWARD & ELIZABETH BOHNE**

**721 CORDOVA ROAD**

**FORT LAUDERDALE, FL 33316**

***721 CORDOVA ROAD, FORT LAUDERDALE, FL 33316***

***EDWARD & ELIZABETH BOHNE • 954-444-2234 • TED@ZCONSTRUCTIONINC.COM***

# **WATERWAY WAIVER APPLICATION**

## **TABLE OF CONTENTS**

Project Description	Page 3
Application	Page 4-5
Warranty Deed & BCPA Information	Page 6-10
Survey	Page 11-12
Zoning Aerial	Page 13-14
Site Photos	Page 15-18
Project Plans & Engineering	Page 19-25
Letters of Support	Page 26-28

# PROJECT DESCRIPTION

The applicants are seeking approval to construct a dock and boatlift on the public property abutting the waterway adjacent to their residence at 721 Cordova Road.

The proposed project, for the private use and enjoyment of the applicants and their personal vessel, includes: a set of stairs to provide access over seawall cap; an L-shaped fixed wood dock of ± 276 square feet; a 4' x 16' aluminum gangway; a 20' x 5' floating dock; and a 30,000 pound capacity cradle boatlift.

The attached plans depict the dock and boatlift extending into the waterway a distance of 30' from the seawall's wet face. As this represents a distance greater than the 25' allowed per Fort Lauderdale's ULDR, the applicants are requesting a variance waiver.

The factors that provide justification for the variance request are as follows:

- Even with the dock at 30' into the waterway, structures will not exceed 30% of the waterway width.
- The waterway is excess of 500' at the point where the applicants intend to install the dock and boatlift, therefore the additional 5' requested will still allow for safe, unimpeded navigation within the waterway.
- The proposed structures will allow the applicants to safely moor their vessel, especially during extreme weather.
- The extra 5' will ensure the vessel is in deep enough water to protect the motors and aquatic resources.
- Having the boatlift further waterward will protect the seawall from potential damage.
- The proposed 8 post beamless cradle lift, will have low profile pilings and lifting mechanisms. The lift will be positioned to allow the vessel to be moored perpendicular to the seawall (Mediterranean style). The result of this is a more pleasing aesthetic for pedestrians and area residents as waterway views won't be blocked.

Environmental permits will be obtained from FDEP, Army Corps of Engineers and Broward County Environmental Protection & Growth Management Department prior to obtaining a building permit from the City of Fort Lauderdale.

**721 CORDOVA ROAD, FORT LAUDERDALE, FL 33316**

**EDWARD & ELIZBETH BOHNE • 954-444-2234 • TED@ZCONSTRUCTIONINC.COM**

# **APPLICATION FOR WATERWAY WAIVER**

*721 CORDOVA ROAD, FORT LAUDERDALE, FL 33316*

*EDWARD & ELIZBETH BOHNE • 954-444-2234 • TED@ZCONSTRUCTIONINC.COM*

**CITY OF FORT LAUDERDALE  
MARINE FACILITIES  
APPLICATION FOR WATERWAY PERMITS, WAIVERS AND LICENSES**

Any agreement with the City of Fort Lauderdale and other parties, such as, but not limited to, licenses, permits and approvals involving municipal docking facilities or private uses in the waterways as regulated by Section 8 of the City Code of Ordinances or Section 47-19.3 of the City's Urban Land Development Regulations, shall be preceded by the execution and filing of the following application form available at the Office of the Supervisor of Marine Facilities. The completed application must be presented with the applicable processing fee paid before the agreement is prepared or the application processed for formal consideration (see City of Fort Lauderdale Code Section 2-157). If legal publication is necessary, the applicant agrees to pay the cost of such publication in addition to the application fee.

**APPLICATION FORM**  
**(Must be in Typewritten Form Only)**

1. LEGAL NAME OF APPLICANT - (If corporation, name and titles of officers as well as exact name of corporation. If individuals doing business under a fictitious name, correct names of individuals, not fictitious names, must be used. If individuals owning the property as a private residence, the name of each individual as listed on the recorded warranty deed):

NAME: **Edward & Elizabeth Bohne**

TELEPHONE NO: 954-444-2234 EMAIL **ted@zconstructioninc.com**  
(home/cellular)

2. APPLICANT'S ADDRESS (if different than the site address):  
**same**

3. TYPE OF AGREEMENT AND DESCRIPTION OF REQUEST:  
**Applicants are requesting a waiver of the 25' maximum waterward projection of proposed dock & boatlift**

4. SITE ADDRESS: **721 Cordova Road, Fort Lauderdale 33316** ZONING: **RS-8**

LEGAL DESCRIPTION AND FOLIO NUMBER:  
**RIO VISTA ISLES UNIT 3 7-47 B LOT 47 S 33.34 LESS W 2 OF S 20, 48 N 33.33 LESS W 2 BLK 30  
504211183660**

5. EXHIBITS (In addition to proof of ownership, list all exhibits provided in support of the applications).  
**Survey, plans, warranty deed, zoning aerial, etc**

  
Applicant's Signature

9/28/21  
Date

=====

The sum of \$ \_\_\_\_\_ was paid by the above-named applicant on the \_\_\_\_\_ of \_\_\_\_\_,  
20\_\_ Received by: \_\_\_\_\_

City of Fort Lauderdale

=====For Official City Use Only=====

**Marine Advisory Board Action**  
Formal Action taken on \_\_\_\_\_

**Commission Action**  
Formal Action taken on \_\_\_\_\_

Recommendation \_\_\_\_\_  
Action \_\_\_\_\_

# **WARRANTY DEED & BCPA INFORMATION**

*721 CORDOVA ROAD, FORT LAUDERDALE, FL 33316*

*EDWARD & ELIZBETH BOHNE • 954-444-2234 • TED@ZCONSTRUCTIONINC.COM*

**This Document Prepared By:**

Bruce K. Herman, Esq., The Herman Law Group, P.A.  
3020 NE 32nd Avenue, Suite 226  
Fort Lauderdale, FL 33308

**Return to:**

Balocco & Abril, PLLC, 4332 East Tradewinds Avenue  
Lauderdale By-The-Sea, FL 33308

Parcel ID Number: 504211-18-3660

## Warranty Deed

This Indenture, Made this <sup>7<sup>th</sup></sup> day of **June**, **2021** A.D., **Between**  
**Louise Dekok, a married woman**  
of the County of **Broward**, State of **Florida**, **grantor**, and  
**Edward J. Bohne, III and Elizabeth Ellen Bohne, husband and wife**  
whose address is: **721 Cordova Road, Fort Lauderdale, FL 33316**  
of the County of **Broward**, State of **Florida**, **grantees.**

**Witnesseth** that the GRANTOR, for and in consideration of the sum of

**TEN DOLLARS (\$10)**

and other good and valuable consideration to GRANTOR in hand paid by GRANTEES, the receipt whereof is hereby acknowledged, has granted, bargained and sold to the said GRANTEES and GRANTEES' heirs, successors and assigns forever, the following described land, situate, lying and being in the County of **Broward**, State of **Florida** to wit:

**See Exhibit "A" attached hereto and made a part hereof.**

**NOTE: This property is NOT the Homestead Property for the Grantor, Louise Dekok. Her Homestead address is 1409 SE 11th Court, Fort Lauderdale, FL 33316.**

**Subject to taxes for 2021 and subsequent years; covenants, conditions, restrictions, easements, reservations and limitations of record, if any.**

**Together with all the tenements, hereditaments and appurtenances thereto belonging or in anywise appertaining.**

**To Have and to Hold, the same in fee simple forever.**

**And the grantor hereby covenants with said grantee that the grantor is lawfully seized of said land in fee simple; that the grantor has good right and lawful authority to sell and convey said land; that the grantor hereby fully warrants the title to said land and will defend the same against the lawful claims of all persons whomsoever; and that said land is free of all encumbrances, except taxes accruing subsequent to December 31, 2020.**

and the grantor does hereby fully warrant the title to said land, and will defend the same against lawful claims of all persons whomsoever.

# Warranty Deed - Page 2

Parcel ID Number: 504211-18-3660

In Witness Whereof, the grantor has hereunto set her hand and seal the day and year first above written.

Signed, sealed and delivered in our presence:

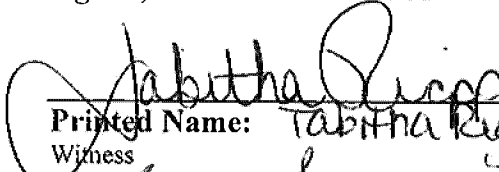
  
 Printed Name: Tabitha Riggs  
 Witness

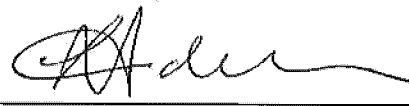
  
 Louise Dekok (Seal)  
 P.O. Address: 1409 SE 11th Court, Fort Lauderdale, FL 33316

  
 Printed Name: LISA A. FEIX  
 Witness

State of Florida  
County of Broward

The foregoing instrument was acknowledged before me by means of  physical presence or  online notarization, this 7<sup>th</sup> day of June, 2021, by Louise Dekok who is personally known to me or who has produced her **Florida's driver license** as identification .

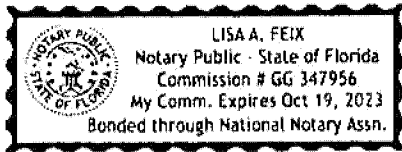

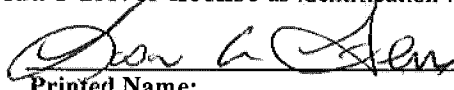
  
 Printed Name:  
 Notary Public  
 My Commission Expires:

## **Exhibit A**

**The South 33.34 feet (measured along the front or East lot line) of Lot 47 and the North 33.33 feet (measured along the front or East lot line) of Lot 48, Block 30, RIO VISTA ISLES, UNIT 3; less a strip of land being two feet (2') in width, lying adjacent to and immediately East of the West line of the South twenty feet (S 20') of Lot 47, Block 30, RIO VISTA ISLES, UNIT 3; less also a strip of land being two feet (2') in width, lying adjacent to and immediately East of the West line of the North 33.33 feet of Lot 48, Block 30, RIO VISTA ISLES, UNIT 3, according to the Plat thereof, recorded in Plat Book 7, Page 47, of the Public Records of Broward County, Florida.**

**PROPERTY SUMMARY**

<b>Tax Year:</b> 2022	<b>Property Use:</b> 01 - Single family	<b>Deputy Appraiser:</b> Residential Department
<b>Property Id:</b> 504211183660	<b>Millage Code:</b> 0312	<b>Appraisers Number:</b> 954-357-6831
<b>Property Owner/s:</b> BOHNE,EDWARD J III H/E BOHNE,ELIZABETH ELLEN	<b>Adj. Bldg. S.F.:</b> 2206	<b>Email:</b> <a href="mailto:realprop@bcpa.net">realprop@bcpa.net</a>
<b>Mailing Address:</b> 721 CORDOVA RD FORT LAUDERDALE, FL 33316	<b>Bldg Under Air S.F.:</b> 1915	<b>Zoning :</b> RS-8 - RESIDENTIAL SINGLE FAMILY/LOW MEDIUM DENSITY
<b>Physical Address:</b> 721 CORDOVA ROAD FORT LAUDERDALE, 33316-1429	<b>Effective Year:</b> 1953	<b>Abbr. Legal Des.:</b> RIO VISTA ISLES UNIT 3 7-47 B LOT 47 S 33.34 LESS W 2 OF S 20, 48 N 33.33 LESS W 2 BLK 30
	<b>Year Built:</b> 1952	
	<b>Units/Beds/Baths:</b> 1 / 3 / 2	

2020 values are considered "working values" and are subject to change.

**PROPERTY ASSESSMENT**

Year	Land	Building / Improvement	Agricultural Saving	Just / Market Value	Assessed / SOH Value	Tax
2022	\$354,000	\$567,090	0	\$921,090	\$921,090	
2021	\$354,000	\$567,090	0	\$921,090	\$921,090	\$17,653.46
2020	\$354,000	\$534,830	0	\$888,830	\$888,830	\$16,968.09

**EXEMPTIONS AND TAXING AUTHORITY INFORMATION**

	County	School Board	Municipal	Independent
Just Value	\$921,090	\$921,090	\$921,090	\$921,090
Portability	0	0	0	0
Assessed / SOH	\$921,090	\$921,090	\$921,090	\$921,090
Granny Flat				
Homestead	0	0	0	0
Add. Homestead	0	0	0	0
Wid/Vet/Dis	0	0	0	0
Senior	0	0	0	0
Exemption Type	0	0	0	0
Affordable Housing	0	0	0	0
Taxable	\$921,090	\$921,090	\$921,090	\$921,090

**SALES HISTORY FOR THIS PARCEL**

Date	Type	Price	Book/Page or Cin
06/07/2021	Warranty Deed Qualified Sale	\$1,182,000	117332858
03/19/2014	Warranty Deed Qualified Sale	\$950,000	112175499
05/01/1987	Warranty Deed	\$205,000	14442 / 752

**LAND CALCULATIONS**

Unit Price	Units	Type
\$40.00	8,850 SqFt	Square Foot

**RECENT SALES IN THIS SUBDIVISION**

Property ID	Date	Type	Qualified/ Disqualified	Price	CIN	Property Address
504211182860	11/12/2021	Warranty Deed	Excluded Sale	\$1,000,000	117732480	1025 S RIO VISTA BLVD FORT LAUDERDALE, FL 33316
504211180660	10/28/2021	Warranty Deed	Qualified New Construction	\$2,433,000	117701375	1108 SE 11 ST FORT LAUDERDALE, FL 33316
504211181820	10/26/2021	Warranty Deed	Qualified Sale	\$3,275,000	117715050	1028 SE 13 TER FORT LAUDERDALE, FL 33316
504211181670	10/19/2021	Warranty Deed	Qualified Sale	\$1,780,000	117679738	1212 PONCE DE LEON DR FORT LAUDERDALE, FL 33316
504211181610	09/24/2021	Warranty Deed	Qualified Sale	\$1,285,000	117647156	1110 PONCE DE LEON DR FORT LAUDERDALE, FL 33316

**SPECIAL ASSESSMENTS**

Fire	Garb	Light	Drain	Impr	Safe	Storm	Clean	Misc
Ft Lauderdale Fire-rescue (03) Residential (R) 1						(F1)  1.00		

**SCHOOL**

**Harbordale Elementary:** A  
**Sunrise Middle:** B  
**Fort Lauderdale High:** A

**ELECTED OFFICIALS**

Property Appraiser	County Comm. District	County Comm. Name	US House Rep. District	US House Rep. Name
Marty Kiar	7	Tim Ryan	22	Ted Deutch
Florida House Rep. District	Florida House Rep. Name	Florida Senator District	Florida Senator Name	School Board Member
93	Chip LaMarca	34	Gary M. Farmer, Jr.	Sarah Leonardi

# **SURVEY**

*721 CORDOVA ROAD, FORT LAUDERDALE, FL 33316*

*EDWARD & ELIZBETH BOHNE • 954-444-2234 • TED@ZCONSTRUCTIONINC.COM*

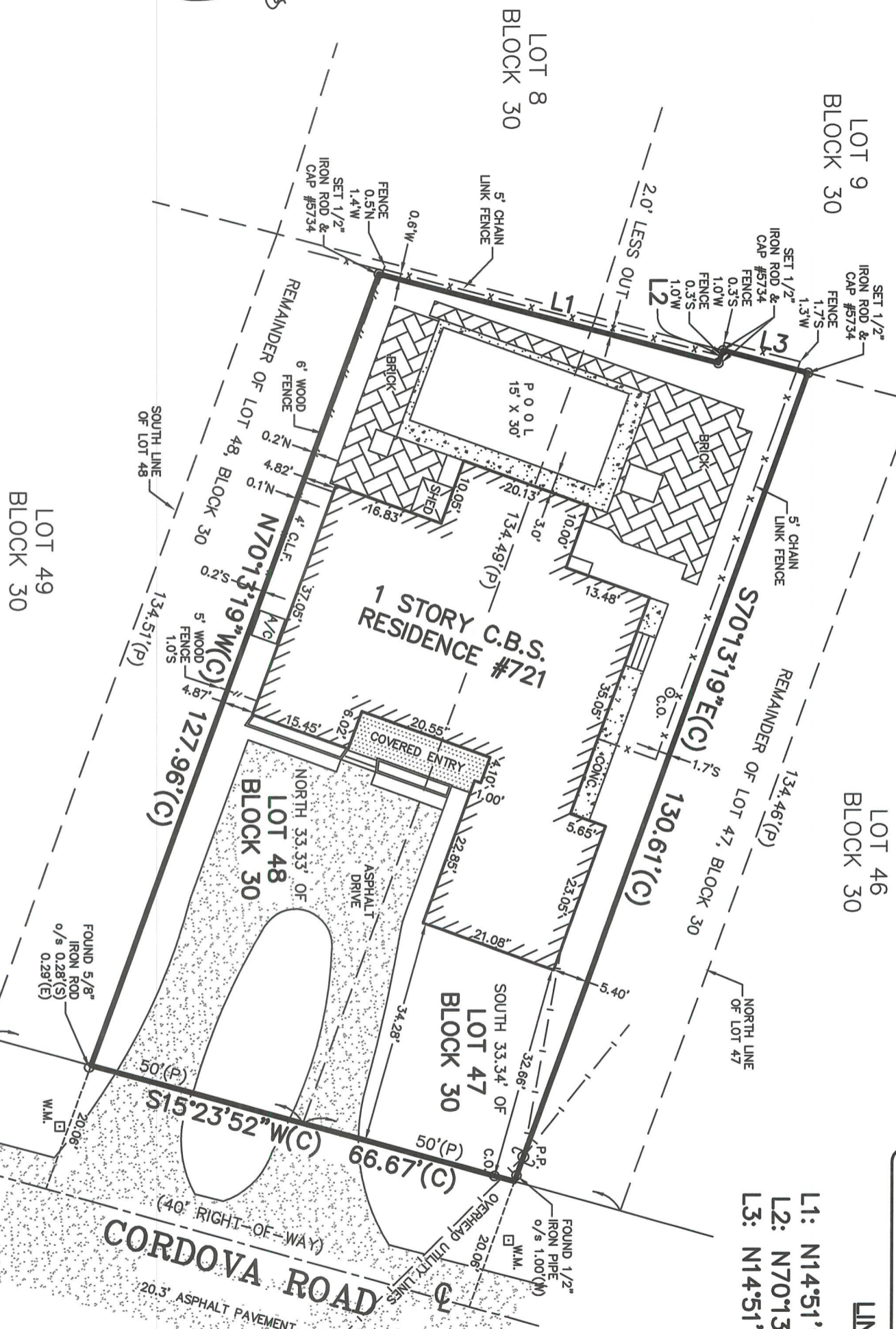

- LINE DATA:**
- L1: N14°51'13"E(C) 53.35'(C)
  - L2: N70°13'19"W(C) 2.01'(C)
  - L3: N14°51'13"E(C) 13.38'(C)

SCALE: 1" = 20'	SKETCH NO.: 21-1142
DRAWN BY: O.D.I.	SIDE 2 OF 2

# AERIAL PHOTOGRAPH

*721 CORDOVA ROAD, FORT LAUDERDALE, FL 33316*

*EDWARD & ELIZBETH BOHNE • 954-444-2234 • TED@ZCONSTRUCTIONINC.COM*

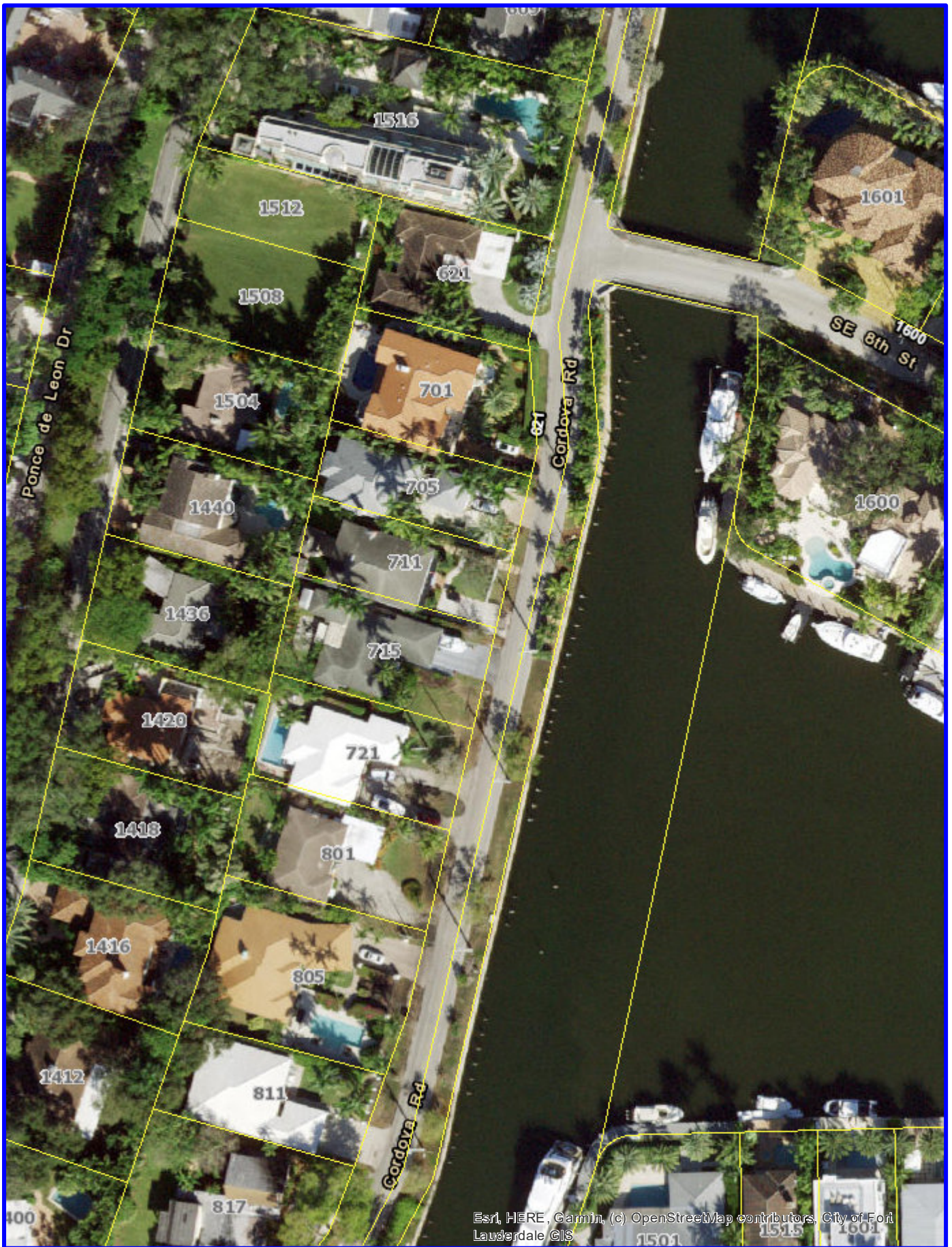

Esri, HERE, Garmin, (c) OpenStreetMap contributors, City of Fort Lauderdale GIS



CITY OF FORT LAUDERDALE

721 Cordova Rd.



0 40 80 Feet

**GIS**  
Fort Lauderdale

# SITE PHOTOS

*721 CORDOVA ROAD, FORT LAUDERDALE, FL 33316*

*EDWARD & ELIZBETH BOHNE • 954-444-2234 • TED@ZCONSTRUCTIONINC.COM*



162





# PROJECT PLANS & ENGINEERING

*721 CORDOVA ROAD, FORT LAUDERDALE, FL 33316*

*EDWARD & ELIZBETH BOHNE • 954-444-2234 • TED@ZCONSTRUCTIONINC.COM*

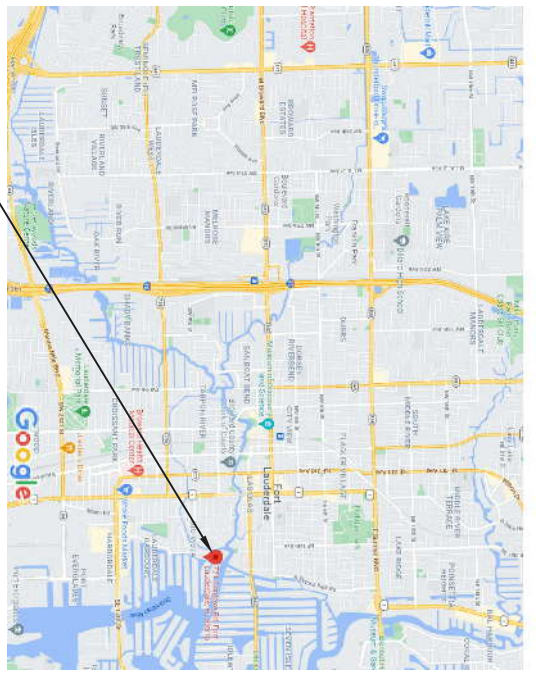

PROJECT LOCATION

LOCATION MAP

PROJECT SITE



AERIAL

**MGR PROFESSIONAL ENGINEERING, INC.**

OF: (561)863-3393

CERTIFICATE OF AUTHORIZATION #09967

MICHAEL BARBER, P.E. #52575

DOCK AND BOAT LIFT

TED BOHNE

721 CORDOVA ROAD  
FORT LAUDERDALE, FL 33316

YACHT LIFTERS, INC.

MARINE CONSTRUCTION  
1126 S FEDERAL HIGHWAY, SUITE 150  
FORT LAUDERDALE, FL 33316

DATE	REVISIONS
10/11/21	INITIAL DRAWINGS COMPLETED

SHEET 1 OF 5

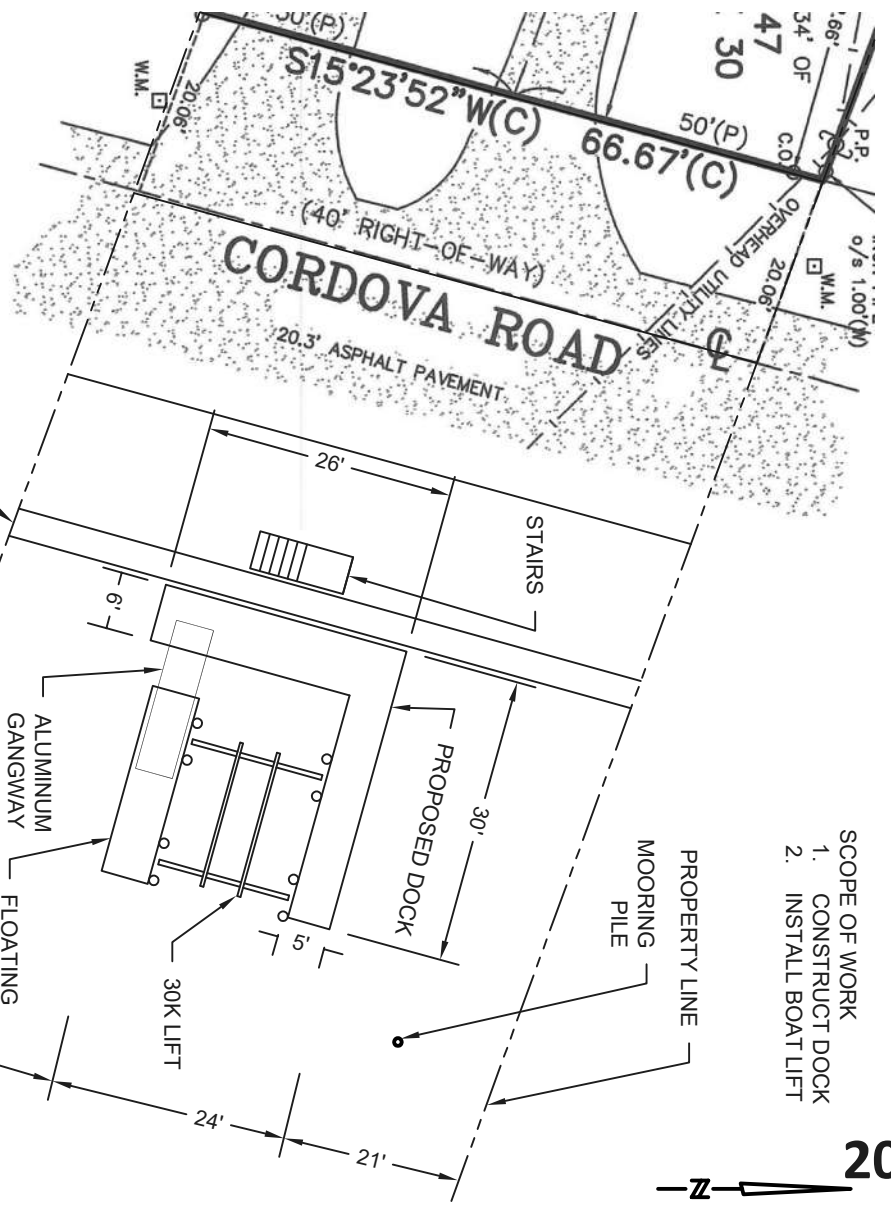

SITE PLAN

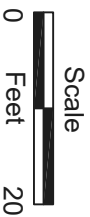

NOTES:

LIFT PILES (8) TO BE INCORPORATED WITH THE 5' x 20' FLOATING DOCK AND THE 5' x 24" FINGER PIER.

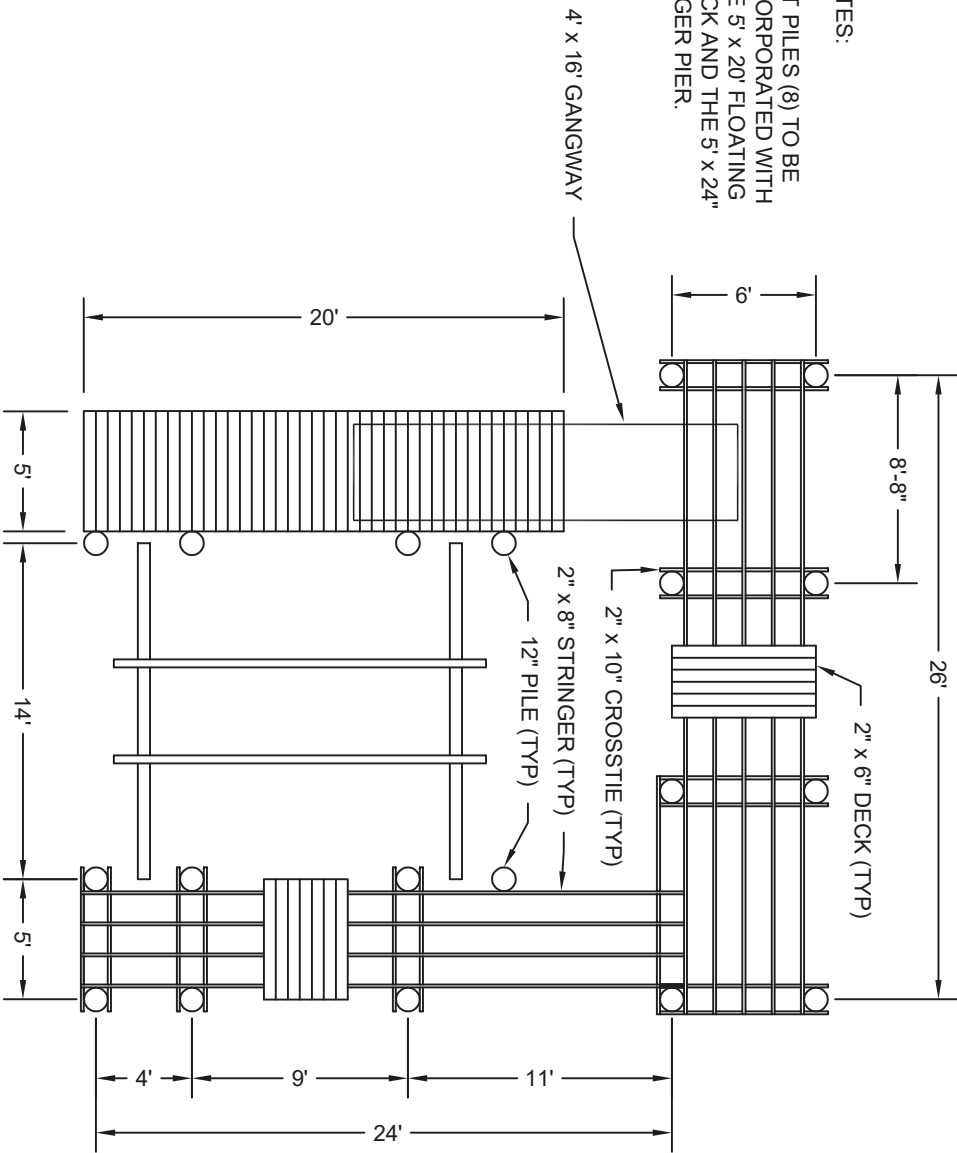

**FRAMING PLAN**  
1/8" = 1'-0"

NOTES:

1. DECKING - COMPOSITE. SPACE STRINGERS IN ACCORDANCE TO MANUF. REQUIREMENTS.
2. FRAMING: BE 2"x8" STRINGERS, 2"x10" CROSS TIES, PT WOOD.
3. DECK FASTENERS TO BE 16d STAINLESS STEEL RING SHANK NAILS OR 3/4" HEX DRIVEN DECK SCREWS. (OR PER MANUFACT.)
4. ALL FRAMING HARDWARE TO BE STAINLESS STEEL.
5. NEW 12" DIA WOOD PILES - WRAPPED IN PERMA PVC.
6. LUMBER TO BE PRESSURE TREATED FOR MARINE ENVIRONMENT. (ACQ OR CCA)
7. LUMBER TO BE #1 QUALITY SOUTHERN YELLOW PINE.

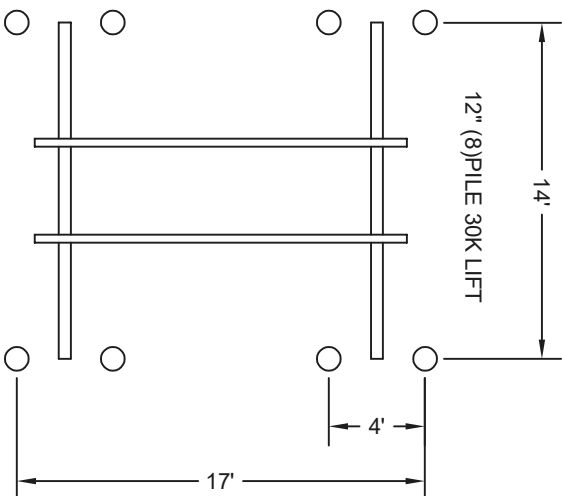

**MGR PROFESSIONAL ENGINEERING, INC.**

OF: (561)863-3393

CERTIFICATE OF AUTHORIZATION #09967

MICHAEL BARBER, P.E. # 52675

**DOCK AND BOAT LIFT**

TED BOHNE

721 CORDOVA ROAD  
FORT LAUDERDALE, FL 33316

YACHT LIFTERS, INC.

MARINE CONSTRUCTION  
1126 S FEDERAL HIGHWAY, SUITE 150  
FORT LAUDERDALE, FL 33316

DATE

10/11/21

REVISIONS

INITIAL DRAWINGS COMPLETED

SHEET 2 OF 5





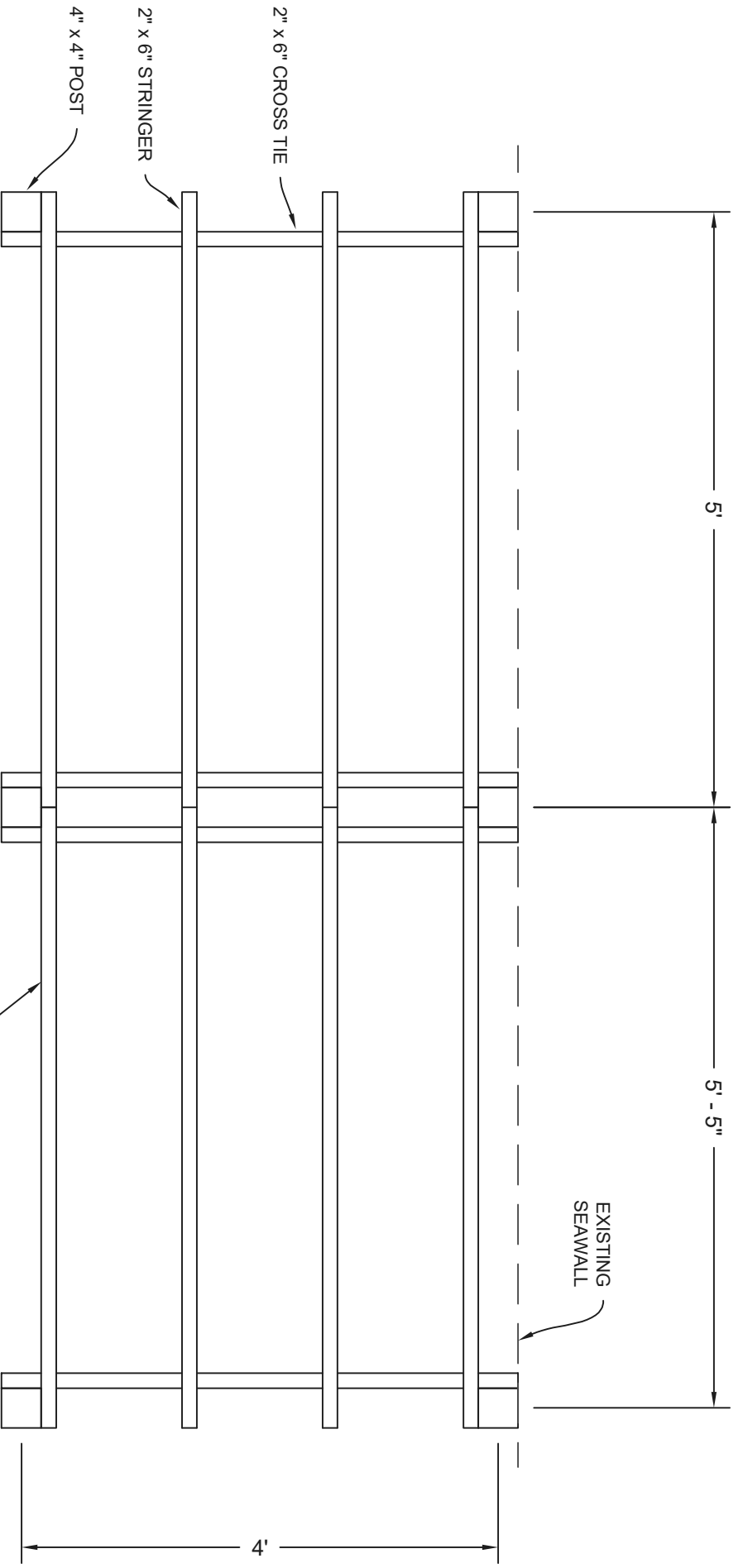

**FRAMING**  
3/4" = 1'-0"

**MGR PROFESSIONAL ENGINEERING, INC.**  
 OF: (561) 863-3393  
 CERTIFICATE OF AUTHORIZATION # 9967  
 STATE OF FLORIDA  
 MICHAEL BARBER, P.E. # 52575

**DOCK AND BOAT LIFT**  
 TED BOHNE  
 721 CORDOVA ROAD  
 FORT LAUDERDALE, FL 33316  
 YACHT LIFTERS, INC.  
 MARINE CONSTRUCTION  
 1126 S FEDERAL HIGHWAY, SUITE 150  
 FORT LAUDERDALE, FL 33316

DATE	REVISIONS
10/11/21	INITIAL DRAWINGS COMPLETED



# Direct Drive 8-Post Yacht Lifts



- All Aluminum and Stainless Steel Construction
- Direct Drive with Industrial Duty Stainless Steel Motors
- Massive, Solid Aluminum Grooved Winders with Exclusive SEArmor Corrosion Resistant Coating
- Heavy Duty, Easily Adjustable Guide Poles
- Solid Aluminum Bearing Blocks with Delrin Bearings
- Welded Construction (not bolted)
- Stainless Steel Cables
- Self-Adjusting Cable Keepers
- Wireless Remote Control and Limit Switch
- Optional Electrical Controls with Multiple Switches
- 10 Year Limited Warranty

\*\*\*See our "Complete list of Other Accessories"

## Specifications

Size	Top Carrier Dimensions	Lifter Beam Dimensions	Horse Power	Volt and Amperage	Cable Size	Winders/ Drive Shaft	Vertical Travel	Bunks	Pile Size
30,000 lb. (w/remote)	6" Channel	12" x 16' I-Beam	(4) 1 HP Stainless Steel Motors	240V/30A	3/8" Stainless Steel	Mil-Spec Hardened Grooved Winders	12'	3" x 12" x 20'	(8) 10" Driven Piling
40,000 lb. (w/remote)	Twin I-Beam	Double I-Beam 16' – 20'	Neptune® Patented 1HP Stainless Steel Magnetic Brake Motors	240V/30A	3/8" Stainless Steel	Mil-Spec Hardened Solid Grooved Winders	12'	5" x 12" x 20'	(8) 10" – 12" Driven Piling
50,000 lb. (w/remote)	Twin I-Beam	Double I-Beam 16' – 20'	Neptune® Patented 2HP Stainless Steel Magnetic Brake Motors	240V/60A	7/16" Stainless Steel	Mil-Spec Hardened Solid Grooved Winders	12'	5" x 12" x 20'	(8) 10" – 12" Driven Piling
60,000 lb. (w/remote)	Twin I-Beam	Double I-Beam 12" 18' – 20'	Neptune® Patented 2HP Stainless Steel Magnetic Brake Motors	240V/60A	7/16" Stainless Steel	Mil-Spec Hardened Solid Grooved Winders	12'	5" x 12" x 20'	(8) 12" Driven Piling
70,000 lb. (w/remote)	Twin I-Beam	Triple I-Beam 12" Double Lifters 18' – 21'	Neptune® Patented 2HP Stainless Steel Magnetic Brake Motors	240V/60A	7/16" Stainless Steel	Mil-Spec Hardened Solid Grooved Winders	12'	5" x 12" x 20'	(8) 12" Driven Piling
80,000 lb (w/remote)	Twin I-Beam	Triple I-Beam 12" Double Lifters 20' – 21'	Neptune® Patented 2HP Stainless Steel Magnetic Brake Motors	240V/60A	7/16" Stainless Steel	Mil-Spec Hardened Solid Grooved Winders	12'	8" x 12" x 20'	(8) 12" Concrete Driven Piling
120,000 lb (w/remote)	Twin I-Beam	Double I-Beam 18" Quad Lifters 20' – 22'	Neptune® Patented 2HP Stainless Steel Magnetic Brake Motors	240V/80A	7/16" Stainless Steel	Mil-Spec Hardened Solid Grooved Winders	12'	8" x 12" x 20'	(8) 12" Concrete Driven Piling
180,000 lb (w/remote)	Twin I-Beam	Double I-Beam 18" Quad Lifters 20' – 22'	Neptune® Patented 2HP Stainless Steel Magnetic Brake Motors	240V/80A	7/16" Stainless Steel	Mil-Spec Hardened Solid Grooved Winders	12'	8" x 12" x 20'	(8) 12" Concrete Driven Piling

# LETTERS OF SUPPORT

*721 CORDOVA ROAD, FORT LAUDERDALE, FL 33316*

*EDWARD & ELIZBETH BOHNE • 954-444-2234 • TED@ZCONSTRUCTIONINC.COM*

November 22, 2021

Marine Advisory Board  
City of Fort Lauderdale  
100 N. Andrews Ave.  
Fort Lauderdale, FL 33301

RE: City of Fort Lauderdale Waiver Request  
721 Cordova Road dock & boatlift installation

Dear Marine Advisory Board Member,

I am writing regarding the dock and boatlift project proposed at 721 Cordova Road. I reside at 805 Cordova Road, Fort Lauderdale, FL and support the project as proposed.

I have reviewed the attached plans (Attachment A) for the proposed project to install a fixed marginal dock, fixed finger pier, floating dock and 30,000-pound capacity cradle boatlift on the waterway adjacent to 721 Cordova Road.

I am aware the proposed project will extend beyond 25 feet from the seawall into the waterway. I understand that the proposed project will require a waiver of limitations through the City of Fort Lauderdale along with permitting through the regulatory agencies.

As stated above, Mr. Bohne has my support and approval for the work as described. Please let me know if I can provide any other information.

Sincerely,

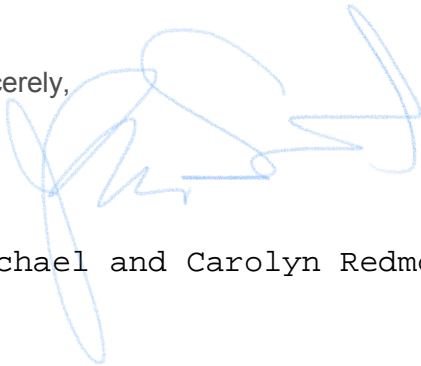
A handwritten signature in blue ink, appearing to read "Michael and Carolyn Redmond". The signature is stylized and somewhat illegible due to the cursive nature of the writing.

Michael and Carolyn Redmond